

To our customers,

Old Company Name in Catalogs and Other Documents

On April 1st, 2010, NEC Electronics Corporation merged with Renesas Technology Corporation, and Renesas Electronics Corporation took over all the business of both companies. Therefore, although the old company name remains in this document, it is a valid Renesas Electronics document. We appreciate your understanding.

Renesas Electronics website: <http://www.renesas.com>

April 1st, 2010
Renesas Electronics Corporation

Issued by: Renesas Electronics Corporation (<http://www.renesas.com>)

Send any inquiries to <http://www.renesas.com/inquiry>.

Notice

1. All information included in this document is current as of the date this document is issued. Such information, however, is subject to change without any prior notice. Before purchasing or using any Renesas Electronics products listed herein, please confirm the latest product information with a Renesas Electronics sales office. Also, please pay regular and careful attention to additional and different information to be disclosed by Renesas Electronics such as that disclosed through our website.
2. Renesas Electronics does not assume any liability for infringement of patents, copyrights, or other intellectual property rights of third parties by or arising from the use of Renesas Electronics products or technical information described in this document. No license, express, implied or otherwise, is granted hereby under any patents, copyrights or other intellectual property rights of Renesas Electronics or others.
3. You should not alter, modify, copy, or otherwise misappropriate any Renesas Electronics product, whether in whole or in part.
4. Descriptions of circuits, software and other related information in this document are provided only to illustrate the operation of semiconductor products and application examples. You are fully responsible for the incorporation of these circuits, software, and information in the design of your equipment. Renesas Electronics assumes no responsibility for any losses incurred by you or third parties arising from the use of these circuits, software, or information.
5. When exporting the products or technology described in this document, you should comply with the applicable export control laws and regulations and follow the procedures required by such laws and regulations. You should not use Renesas Electronics products or the technology described in this document for any purpose relating to military applications or use by the military, including but not limited to the development of weapons of mass destruction. Renesas Electronics products and technology may not be used for or incorporated into any products or systems whose manufacture, use, or sale is prohibited under any applicable domestic or foreign laws or regulations.
6. Renesas Electronics has used reasonable care in preparing the information included in this document, but Renesas Electronics does not warrant that such information is error free. Renesas Electronics assumes no liability whatsoever for any damages incurred by you resulting from errors in or omissions from the information included herein.
7. Renesas Electronics products are classified according to the following three quality grades: "Standard", "High Quality", and "Specific". The recommended applications for each Renesas Electronics product depends on the product's quality grade, as indicated below. You must check the quality grade of each Renesas Electronics product before using it in a particular application. You may not use any Renesas Electronics product for any application categorized as "Specific" without the prior written consent of Renesas Electronics. Further, you may not use any Renesas Electronics product for any application for which it is not intended without the prior written consent of Renesas Electronics. Renesas Electronics shall not be in any way liable for any damages or losses incurred by you or third parties arising from the use of any Renesas Electronics product for an application categorized as "Specific" or for which the product is not intended where you have failed to obtain the prior written consent of Renesas Electronics. The quality grade of each Renesas Electronics product is "Standard" unless otherwise expressly specified in a Renesas Electronics data sheets or data books, etc.
 - "Standard": Computers; office equipment; communications equipment; test and measurement equipment; audio and visual equipment; home electronic appliances; machine tools; personal electronic equipment; and industrial robots.
 - "High Quality": Transportation equipment (automobiles, trains, ships, etc.); traffic control systems; anti-disaster systems; anti-crime systems; safety equipment; and medical equipment not specifically designed for life support.
 - "Specific": Aircraft; aerospace equipment; submersible repeaters; nuclear reactor control systems; medical equipment or systems for life support (e.g. artificial life support devices or systems), surgical implantations, or healthcare intervention (e.g. excision, etc.), and any other applications or purposes that pose a direct threat to human life.
8. You should use the Renesas Electronics products described in this document within the range specified by Renesas Electronics, especially with respect to the maximum rating, operating supply voltage range, movement power voltage range, heat radiation characteristics, installation and other product characteristics. Renesas Electronics shall have no liability for malfunctions or damages arising out of the use of Renesas Electronics products beyond such specified ranges.
9. Although Renesas Electronics endeavors to improve the quality and reliability of its products, semiconductor products have specific characteristics such as the occurrence of failure at a certain rate and malfunctions under certain use conditions. Further, Renesas Electronics products are not subject to radiation resistance design. Please be sure to implement safety measures to guard them against the possibility of physical injury, and injury or damage caused by fire in the event of the failure of a Renesas Electronics product, such as safety design for hardware and software including but not limited to redundancy, fire control and malfunction prevention, appropriate treatment for aging degradation or any other appropriate measures. Because the evaluation of microcomputer software alone is very difficult, please evaluate the safety of the final products or system manufactured by you.
10. Please contact a Renesas Electronics sales office for details as to environmental matters such as the environmental compatibility of each Renesas Electronics product. Please use Renesas Electronics products in compliance with all applicable laws and regulations that regulate the inclusion or use of controlled substances, including without limitation, the EU RoHS Directive. Renesas Electronics assumes no liability for damages or losses occurring as a result of your noncompliance with applicable laws and regulations.
11. This document may not be reproduced or duplicated, in any form, in whole or in part, without prior written consent of Renesas Electronics.
12. Please contact a Renesas Electronics sales office if you have any questions regarding the information contained in this document or Renesas Electronics products, or if you have any other inquiries.

(Note 1) "Renesas Electronics" as used in this document means Renesas Electronics Corporation and also includes its majority-owned subsidiaries.

(Note 2) "Renesas Electronics product(s)" means any product developed or manufactured by or for Renesas Electronics.

To all our customers

Regarding the change of names mentioned in the document, such as Mitsubishi Electric and Mitsubishi XX, to Renesas Technology Corp.

The semiconductor operations of Hitachi and Mitsubishi Electric were transferred to Renesas Technology Corporation on April 1st 2003. These operations include microcomputer, logic, analog and discrete devices, and memory chips other than DRAMs (flash memory, SRAMs etc.) Accordingly, although Mitsubishi Electric, Mitsubishi Electric Corporation, Mitsubishi Semiconductors, and other Mitsubishi brand names are mentioned in the document, these names have in fact all been changed to Renesas Technology Corp. Thank you for your understanding. Except for our corporate trademark, logo and corporate statement, no changes whatsoever have been made to the contents of the document, and these changes do not constitute any alteration to the contents of the document itself.

Note : Mitsubishi Electric will continue the business operations of high frequency & optical devices and power devices.

Renesas Technology Corp.
Customer Support Dept.
April 1, 2003

DESCRIPTION

M66235 is produced using the silicon gate CMOS process. It is able to output clock input signal in sync with optional external trigger input signal.

It features excellent synchronizing precision (jitter) over a wide frequency band range.

FEATURES

- 5V single power supply ($5V \pm 5\%$)
- Frequency band: 25 ~ 52MHz
- Synchronizing precision (jitter): $\pm 3ns$
- Output types
 - (1) Output of the same frequency as input clock, and its inversion
 - (2) 1/2 divider clock output and its inversion
 - (3) One-shot pulse output
 - (4) Continuous clock output
- Noise in the positive direction to trigger input is removed by built-in noise killer circuit

APPLICATION

Clock phase control for horizontal synchronization

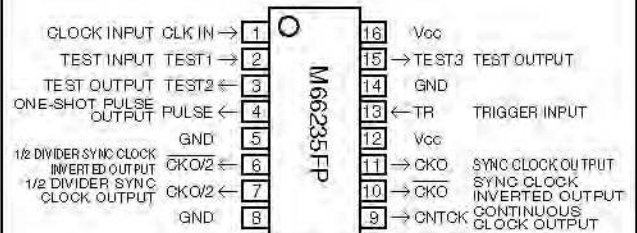
PIN CONFIGURATION (TOP VIEW)**Outline 16P2N-A**

Note: Keep test pins (TEST 1 to 3) open

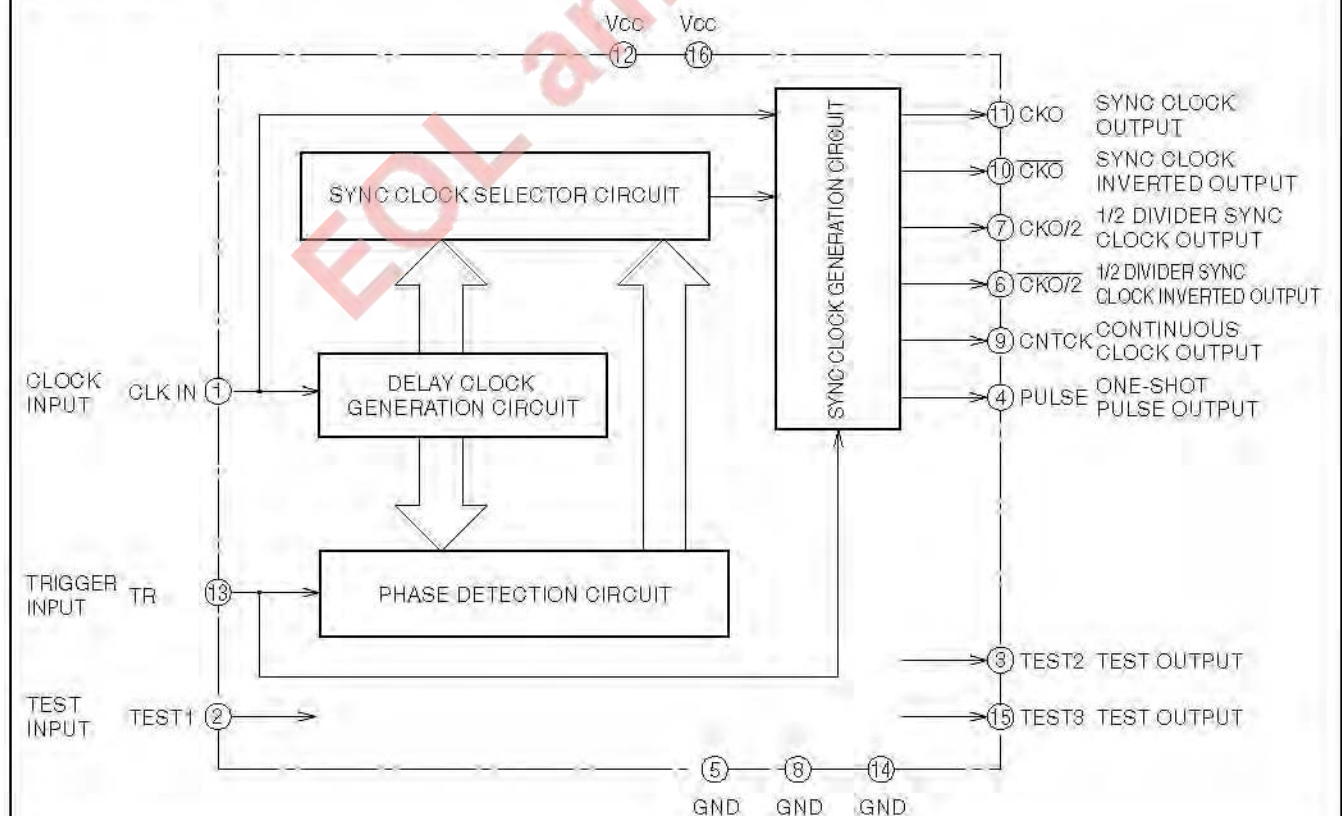
BLOCK DIAGRAM

FUNCTION

M66235 standard clock generator outputs clock input signal, which is input to CLK IN, synchronously with optional trigger signal, which is input to TR.

Sync clock output timing is determined by trigger input signal fall edge. Time-lag between trigger input signal fall edge and sync clock output equals the sum of clock input signal "L" pulse width and M66235 internal delay. Variation in this lag (Δt) is $\pm 3\text{ns}$, ensuring excellent synchronizing accuracy.

There are six types of outputs: synchronous clock output (CKO), synchronous clock inverted output ($\overline{\text{CKO}}$), 1/2 divider synchronous clock output (CKO/2), 1/2 divider synchronous clock inverted output ($\overline{\text{CKO/2}}$), one-shot pulse output (PULSE) and continuous clock output (CNTCK).

From synchronous clock output (CKO), sync clock of the same frequency as clock input signal is output. From synchronous clock inverted output ($\overline{\text{CKO}}$), inverted signal of sync

clock output from CKO is output. From 1/2 divider synchronous clock output (CKO/2), 1/2 divider signal of sync clock output from CKO is output. From 1/2 divider synchronous clock inverted output ($\overline{\text{CKO/2}}$), inverted signal of that output from CKO/2 is output.

From one-shot pulse output (PULSE), one-shot pulse which is almost equal to two cycles of clock input signal is output after trigger input signal falls. From continuous clock output (CNTCK), sync clock is output when trigger input signal is on "L" level; when trigger input signal is on "H" level, clock input signal, which is input to CLK IN, is output.

All these outputs but continuous clock output are suspended when trigger input signal is on "H" level: Synchronous clock output, 1/2 divider synchronous clock output and one-shot pulse output stay on "L" level, and synchronous clock inverted output and 1/2 divider synchronous clock inverted output stay on "H" level.

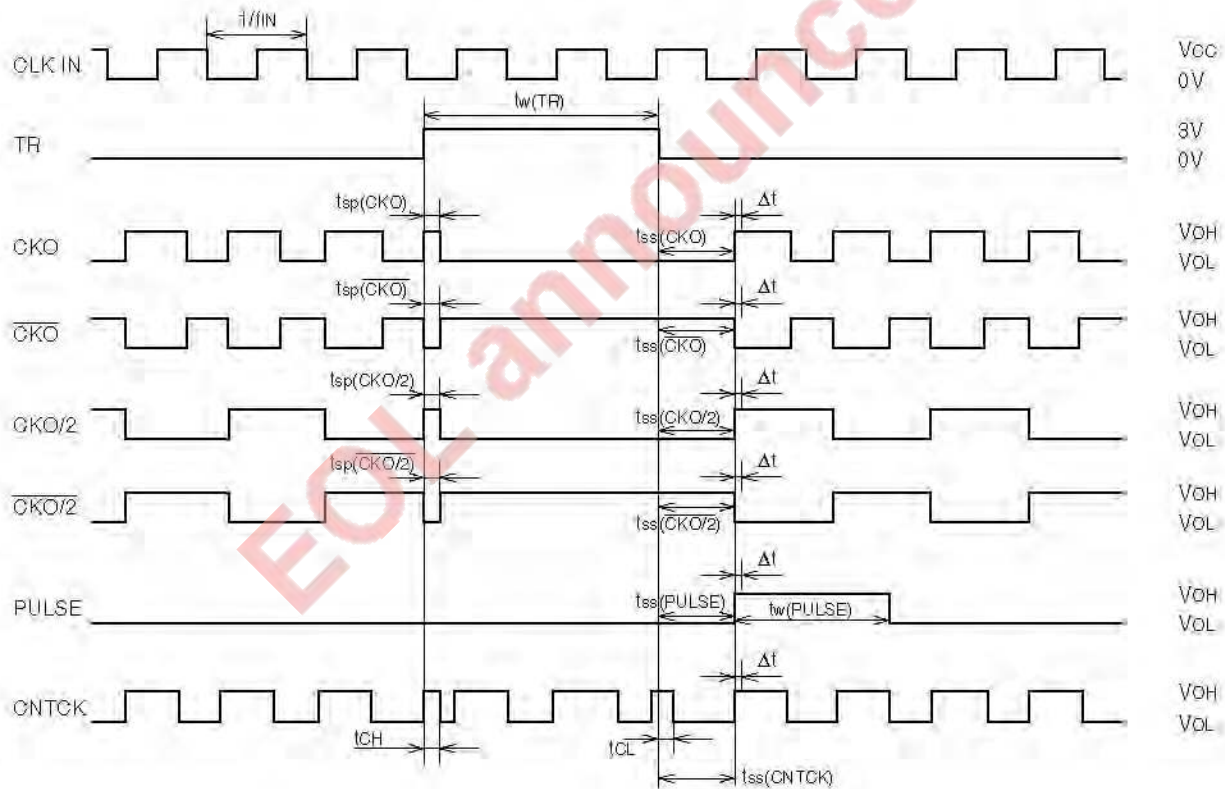

Note 1: $t_{ss}(\text{CKO}, \overline{\text{CKO}}, \text{CKO/2}, \overline{\text{CKO/2}}$ and PULSE) equals the sum of input clock "L" width and α . Value α refers to internal delay in M66235. Under environment where temperature and V_{CC} do not change, value α and t_{ss} are kept constant. Dispersion of t_{ss} under such conditions is defined as Δt [synchronizing precision (jitter)].

Note 2: Outputs ($\overline{\text{CKO}}, \overline{\text{CKO/2}}, \text{PULSE}$ and CNTCK) are unknown until trigger input TR reaches "H" level for the first time after power-on.

After Power-on Procedure

After power-on, M66235 status is unknown till the trigger input being set to the "H" level.

To get a accurate sync clock output, please keep a following procedure.

Please hold the trigger input "H" level during more than $t_w(TR)$ after the input clock frequency being stable.

Also, in case of changing the clock input frequency(f_{IN}), please keep the same procedure.

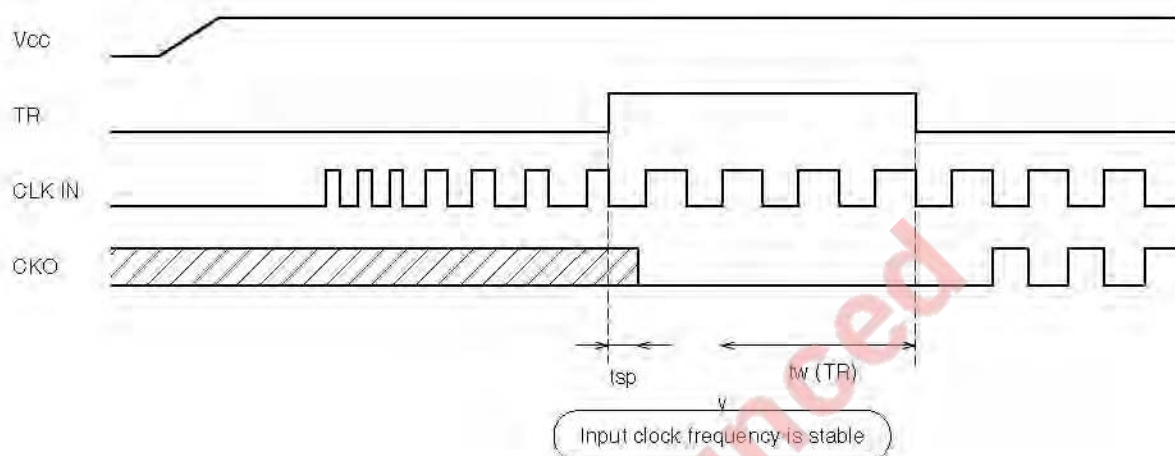

EOL announced

ABSOLUTE MAXIMUM RATINGS

Symbol	Parameter	Conditions	Ratings	Unit
V _{CC}	Supply voltage		-0.5 ~ +7.0	V
V _I	Input voltage		-0.5 ~ V _{CC} +0.5	V
V _O	Output voltage		-0.5 ~ V _{CC} +0.5	V
P _d	Power dissipation	When mounted	750	mW
T _{stg}	Storage temperature		-65 ~ 150	°C

RECOMMENDED OPERATING CONDITIONS (T_a = 0 ~ 70°C unless otherwise noted)

Symbol	Parameter	Limits			Unit
		Min	Typ	Max	
V _{CC}	Supply voltage	4.75	5	5.25	V
GND	Supply voltage		0		V
V _I	Input voltage	0		V _{CC}	V
V _O	Output voltage	0		V _{CC}	V
T _{opr}	Operating temperature	0		70	°C

ELECTRICAL CHARACTERISTICS (T_a = 0 ~ 70°C, V_{CC} = 5V ±5%, GND = 0V)

Symbol	Parameter	Test conditions	Limits			Unit
			Min	Typ	Max	
V _{IH}	"H" input voltage	TR	2			V
V _{IL}	"L" input voltage				0.8	V
V _{IH}	"H" input voltage	CLK IN	0.8 × V _{CC}			V
V _{IL}	"L" input voltage				0.2 × V _{CC}	V
V _{OH}	"H" output voltage	GND = 0V, I _{OH} = -4mA	V _{CC} - 0.8			V
V _{OL}	"L" output voltage	GND = 0V, I _{OL} = 4mA			0.55	V
I _{CC} (s)	Supply current (static)	GND = 0V, V _I = V _{CC} or GND			50	μA
I _{CC} (a)	Supply current (active)	GND = 0V, f _{IN} = 52MHz, V _I = V _{CC} or GND			130	mA
I _{IH}	"H" input current	GND = 0V, V _I = V _{CC}			+1	μA
I _{IL}	"L" input current	GND = 0V, V _I = 0V			-1	μA
C _I	Input capacitance				10	pF

TIMING REQUIREMENTS (T_a = 0 ~ 70°C, V_{CC} = 5V ±5%, GND = 0V)

Symbol	Parameter	Test conditions	Limits			Unit
			Min	Typ	Max	
f _{IN}	Clock input frequency		25		52	MHz
f _{DUTY}	Clock input duty		40		60	%
t _w (TR)	Trigger input "H" pulse width		200			ns
t _r	Clock input rise time				5	ns
t _f	Clock input fall time				5	ns

SWITCHING CHARACTERISTICS ($T_a = 0 \sim 70^\circ\text{C}$, $V_{CC} = 5V \pm 5\%$, $GND = 0V$)

Symbol	Parameter	Test conditions	Limits			Unit
			Min	Typ	Max	
Δt	Synchronizing precision (jitter)	CL=15pF			± 3	ns
$t_{ss}(\overline{CKO})$	Sync clock output start time				$t_{LP} + 50$	ns
$t_{ss}(\overline{CKO})$	Sync clock inverted output start time				$t_{LP} + 50$	ns
$t_{ss}(\overline{CKO}/2)$	1/2 divider sync clock output start time				$t_{LP} + 50$	ns
$t_{ss}(\overline{CKO}/2)$	1/2 divider sync clock inverted output start time				$t_{LP} + 50$	ns
$t_{ss}(\text{PULSE})$	One-shot pulse output start time				$t_{LP} + 50$	ns
$t_{ss}(\text{CNTCK})$	Continuous clock output start time				$t_{LP} + 50$	ns
$t_{sp}(\overline{CKO})$	Sync clock output stop time				40	ns
$t_{sp}(\overline{CKO})$	Sync clock inverted output stop time				40	ns
$t_{sp}(\overline{CKO}/2)$	1/2 divider sync clock output stop time				40	ns
$t_{sp}(\overline{CKO}/2)$	1/2 divider sync clock inverted output stop time				40	ns
$t_w(\text{PULSE})$	One-shot pulse output width			$2t_p - 10$	$2t_p + 10$	ns
tCH	Sync clock-Input clock switching time				40	ns
tCL	Input clock-Sync clock switching time				30	ns
fDUTY(CKO)	Sync clock output duty			30	70	%
fDUTY(\overline{CKO})	Sync clock inverted output duty					%

• $t_p = 1/f_{IN}$, $t_{LP} = t_p \times (100 - f_{DUTY})/100$

• Switching test waveform

Input pulse level CLK IN: 0 to V_{CC}
TR: 0 to 3V

Input pulse rise time: 3ns

Input pulse fall time: 3ns

Critical voltage

Input voltage CLK IN: $V_{CC}/2$
TR: 1.3V

Output voltage: $V_{CC}/2$ for all outputs

• Capacitance: CL includes stray wiring capacitance and probe input capacitance.

TEST CIRCUIT

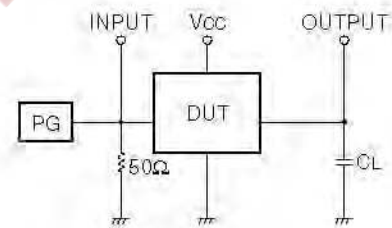

TIMING DIAGRAM

