

500mA Li-ion/Polymer Battery Charger

Features

- A Constant-Current / Constant-Voltage Linear Charger for Single-Cell Li-ion/Polymer Batteries
- Integrated Pass Element and Current Sensor
- Highly-Integrated, Requiring No External FETs or Blocking Diode
- $\pm 0.5\%$ 4.2V Voltage Accuracy at Room Temperature. $\pm 1\%$ All Temperatures. (Available with 4.1V and 4.36V options upon request)
- Programmable Charge Current 50mA to 500mA
- Programmable End-Of-Charge Current by Current Recharge Algorithm
- Pre-Charge for Fully Discharged Batteries
- Less Than $1\mu\text{A}$ Leakage Current Of the Battery when No Input Power Attached or Charger Disabled
- Power Present and Charge Status Indications
- Thermal Regulation on Charging Current to Prevent Over-Heat
- Available with 8-pin 2x3 TDFN Package

Applications

- Cell-phones, PDA, MP3, MP4, PMP
- Standalone Chargers
- Bluetooth Applications

Description

The PT8A2803 is a fully integrated single-cell Li-ion/Polymer battery charger. The charger operates in a constant-current-constant-voltage (CC/CV) charging profile without employing external FETs and blocking diodes.

The fast charge current and end-of-charge (EOC) current can be easily programmed by modifying two external resistors. When the battery is deeply discharged to lower than 2.8V, the charger firstly pre-charges the battery with typically 20% of the programmable fast charge current. When the charge current is reduced to the programmed EOC current level (almost works completely in a constant-voltage (CV) mode), an EOC indication is displayed through the $\overline{\text{CHG}}$ pins. PT8A2803 is protected by thermal regulation technology to prevent the IC from over-heat during charging.

Two status indication pins ($\overline{\text{PPR}}$ and $\overline{\text{CHG}}$), which are both implemented as an open-drain outputs, can be used to drive LEDs or work as logic interface to a microprocessor. When no adapter is attached or when the charger is disabled, the leakage current from battery cell is less than $1\mu\text{A}$ typically.

Pin Assignment

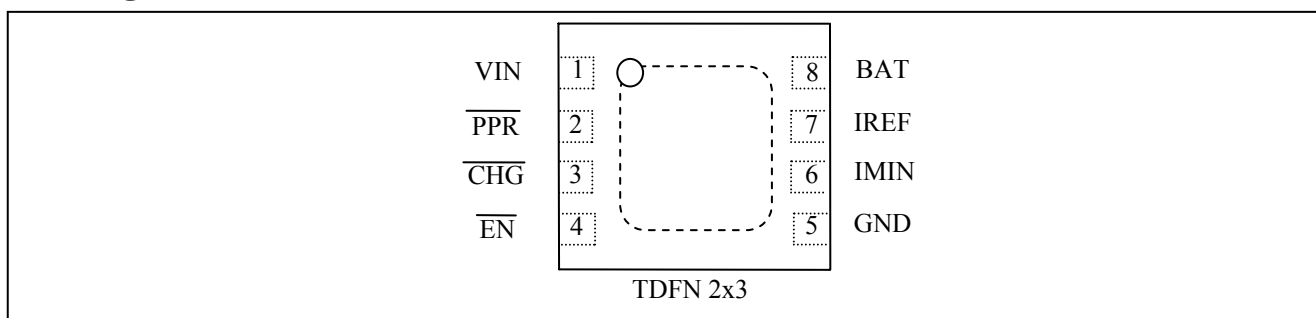

Pin Description

Pin	I/O	Name	Descriptions
1	I/O	VIN	Supply Input.
2	O	$\overline{\text{PPR}}$	Power Present Active-Low Open Drain Power Status Indicator
3	O	$\overline{\text{CHG}}$	Charge Active-Low Open Drain Charge Status Indicator
4	I	$\overline{\text{EN}}$	Enable Active-Low Input
5	I/O	GND	Ground
6	I	IMIN	End-Of-Charge Current Setting Input
7	I	IREF	Charge Current Setting Input
8	O	BAT	Battery Terminal

Maximum Ratings

Storage Temperature.....	-65°C to +150°C
Supply Voltage to Ground Potential (V_{IN} PT8A2803).....	-0.3V to +7.0V
Supply Voltage to Ground Potential ($I_{MIN}/I_{REF}/\overline{BAT}/\overline{CHG}/\overline{EN}/\overline{PPR}$).....	0.3V to +7.0V
Thermal Resistance (Typical for TDFN Package).....	0JA (°C/W)=59
.....	0JC (°C/W)=4.5

Note:

Stresses greater than those listed under **MAXIMUM RATINGS** may cause permanent damage to the device. This is a stress rating only and functional operation of the device at these or any other conditions above those indicated in the operational sections of this specification is not implied. Exposure to absolute maximum rating conditions for extended periods may affect reliability.

Recommended Operating Conditions

Sym	Parameter	Min	Typ	Max	Unit
V_{IN}	Operating Voltage	4.3	-	5.5	V
	Programmable Current	50	-	500	mA
T_A	Operating temperature	-30	-	+85	°C

Electrical Specifications

Typical values are at $V_{IN}=5V$ and $T_A=25^\circ C$. All maximum and minimum values are at $T_A = -30^\circ C$ to $+85^\circ C$, unless otherwise noted.

Parameter	Sym	Conditions	Min	Typ	Max	Units
POWER-ON RESET						
Rising POR Threshold	V_{POR}	$V_{BAT}=3.0V$, use \overline{PPR} to indicate the output	3.3	3.9	4.3	V
Falling POR Threshold	V_{POR}		3.1	3.6	4.15	V
VIN-VBAT OFFSET VOLTAGE						
Rising Edge	V_{OS}	$V_{BAT}=4.0V$, use \overline{CHG} pin to indicate the comparator output	-	90	150	mV
Falling Edge	V_{OS}		10	50	-	mV
STANDBY CURRENT						
BAT pin sink current	I_{STBY}	Charger disabled or the input is floating	-	1	-	μA
DC Supply Current	I_{DC}	Charger disabled	-	300	400	μA
DC Supply Current	I_{DC}	Charger enabled	-	500	700	μA
VOLTAGE REGULATION						
Output voltage	V_{CH}	$4.3V < V_{IN} < 5.5V$ Charge current=20mA	4.158	4.20	4.242	V
Power FET "ON" Resistance	$R_{DS(ON)}$	$V_{BAT}=3.8V$, charge current=0.5A, $R_{IREF}=8k\Omega$	-	0.6	-	Ω
CHARGE CURRENT						
Constant Charge Current	I_{CHG}	$R_{IREF}=29.4k\Omega$, $V_{BAT}=2.8-4.0V$	135	150	165	mA
Precharge Charge Current	I_{PRE}	$R_{IREF}=29.4k\Omega$, $V_{BAT}=2.4V$	18	25	32	mA
End of Charge Current	I_{MIN}	$R_{IMIN}=137k\Omega$	20	30	40	mA
EOC Rising Threshold	I_{RECHG}	$R_{IREF}=29.4k\Omega$	90	100	130	mA
PRECHARGE CHARGE THRESHOLD						
Precharge Threshold Voltage	V_{PRE}	-	2.45	2.55	2.65	V
Precharge Voltage Hysteresis	V_{PREHYS}	-	40	100	150	mV
INTERNAL TEMPERATURE MONITORING						
Thermal regulation threshold (Note)	T_{FOLD}	-	-	115	-	°C
LOGIC INPUT AND OUTPUTS						
\overline{EN} Pin Logic Input High	V_{ENH}	-	1.3	-	-	V
\overline{EN} Pin Logic Input Low	V_{ENL}	-	-	-	0.5	V
\overline{EN} Pin Internal Pull Down Resistance	R_{EN}	-	100	200	400	k Ω
\overline{CHG} Pin Sink Current When LOW	I_{CHGOL}	$V_{CHG}=1V$	10	20	-	mA
\overline{CHG} Pin Leakage Current When HIGH	I_{CHGOH}	$V_{CHG}=5.5V$	-	-	1	μA
\overline{PPR} Pin Sink Current When LOW	I_{PPROL}	$V_{PPR}=1V$	10	20	-	mA
\overline{PPR} Pin Leakage Current When HIGH	I_{PPROH}	$V_{PPR}=5.5V$	-	-	1	μA

Note: This parameter is guaranteed by design, not tested.

Application Circuits

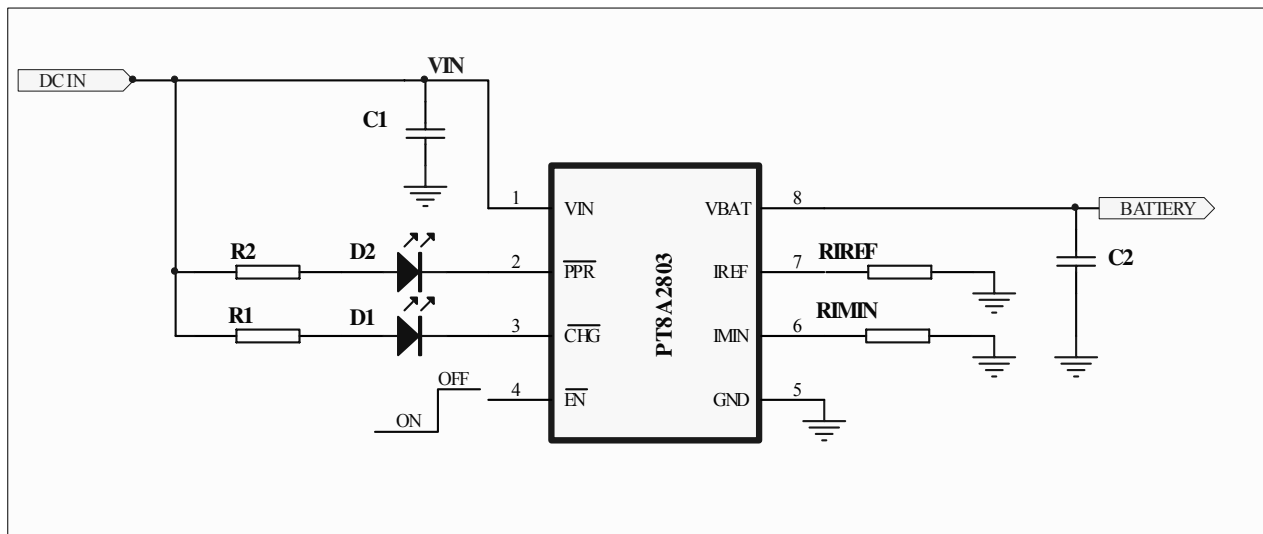

Figure 1 PT8A2803 Typical Application Circuit to Indication LEDs

Component Description for Figure 1

Part	Description
C1	1µF X5R ceramic cap
C2	1µF X5R ceramic cap
RREF	29.4kΩ, 1% for 150mA charge current
RIMIN	294kΩ, 1% for 15mA EOC current
R1, R2	300Ω, 5%
D1, D2	LEDs for indication

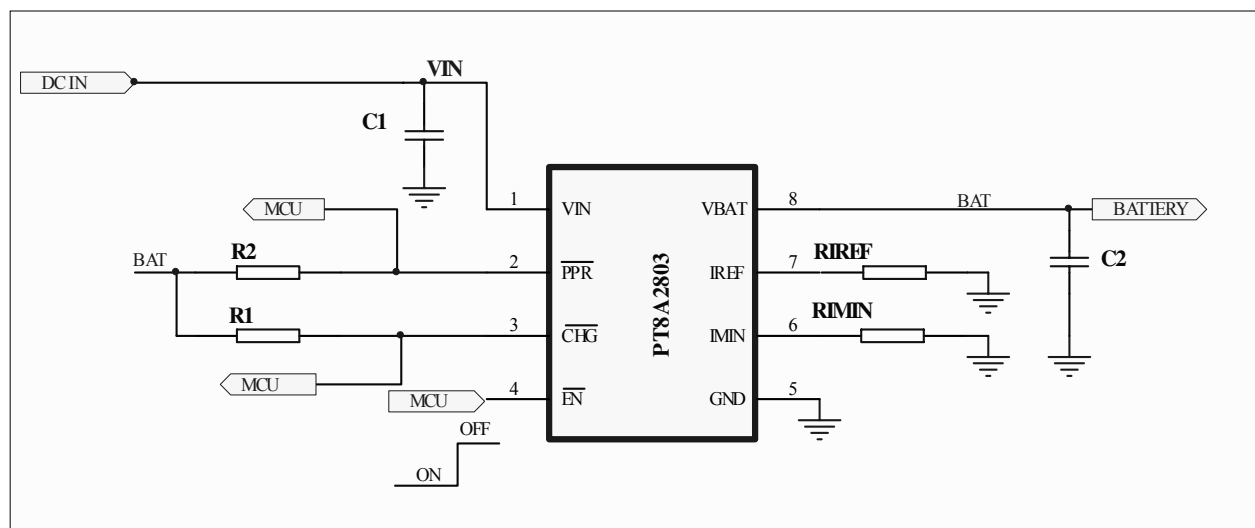

Figure 2 PT8A2803 Typical Application Circuit Interfacing to a MCU

Component Description for Figure 2

Part	Description
C1	1µF X5R ceramic cap
C2	1µF X5R ceramic cap
RREF	29.4kΩ, 1% for 150mA charge current
RIMIN	294kΩ, 1% for 15mA EOC current
R1, R2	100kΩ, 5%

Function block diagram

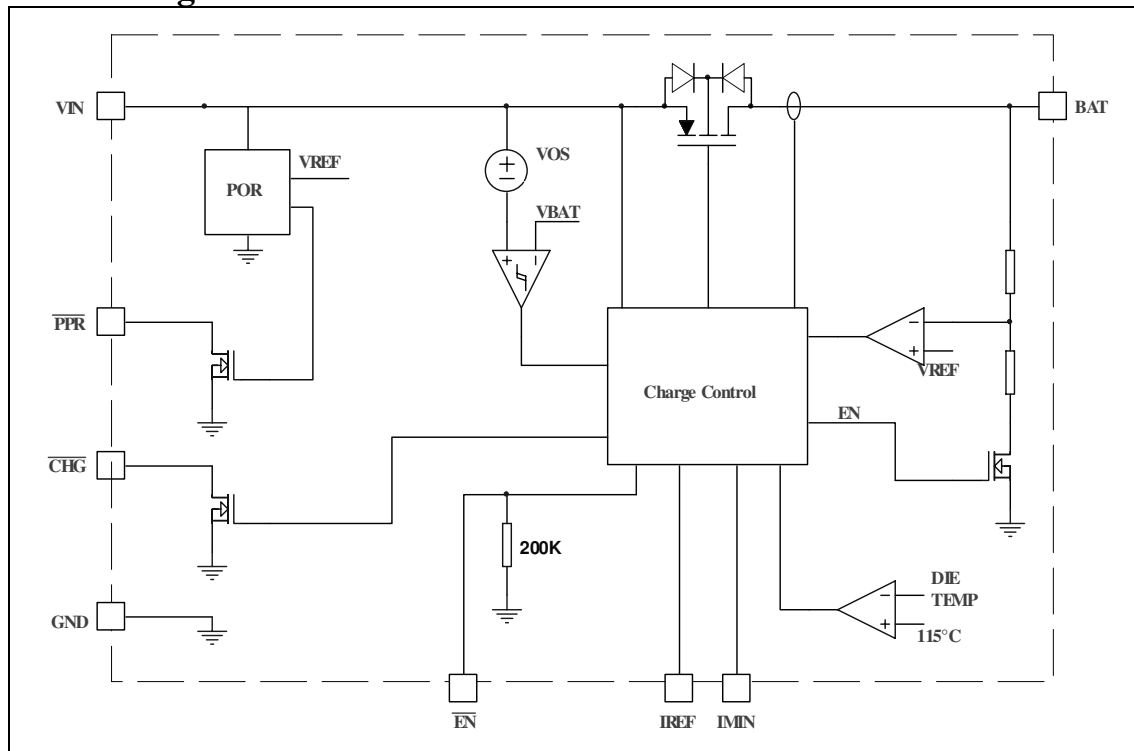

Figure 3 Block diagram of PT8A2803

Functional Description (Refer to Function Block Diagram)

The PT8A2803 charges a single-cell Li-ion/Polymer battery with a programmable constant current (CC) or a constant voltage (CV) algorithm. The fast charge current (ICHG) can be programmed by setting an external resistor RIREF (see **Figure 1/2**) while constant voltage is factory-trimmed at 4.2V (4.1V or 4.36V) options area available upon request). If the battery voltage was deeply discharged to lower than 2.55V, PT8A2803 firstly pre-charges the battery with 20% of the programmed fast charge current. Normally, the battery voltage rises gradually during CC charge phase. When the battery voltage reaches almost 4.2V, the charger enters the constant-voltage (CV) charging mode and begins to regulate the battery voltage at 4.2V while diminishing the charging current gradually. When charging current is reduced to an amount smaller than the programmed End-Of-Charge (EOC) current level, the charger gives out a “full-charge” indication through the CHG pin, but the charger still continues to regulate the battery voltage at 4.2V with safe & small current. **Figure 4** shows the typical charge profile with the EOC/reset event.

PT8A2803 employs current recharge algorithm. The end-of charge (EOC) current level can be easily programmed with an external resistor RIMIN (see **Figure 3/4**). The $\overline{\text{CHG}}$ signal turns to LOW when pre-charge starts and rises to HIGH when EOC is reached. After reaching EOC, the charge current has to rise to typically 76% ICHG before the $\overline{\text{CHG}}$ signal will turn on again, as shown in **Figure 4**. The current surge after EOC can be caused by a load connected to the battery.

When the die temperature reaches 115°C (typically) during charging, a thermal regulation function is employed to reduce the charge current accordingly to maintain the temperature from increasing furthermore. This is an important function to achieve safe operation especially when the printed circuit board (PCB) is not effective in leaking out heat generated by the linear charger.

PPR Indication

The $\overline{\text{PPR}}$ pin is implemented as an open-drain output to provide a power-good indication of the input power source such as an AC adapter. When the input voltage is higher than the POR (Power-On Reset) threshold, the $\overline{\text{PPR}}$ pin turns on the internal open-drain MOSFET to indicate a logic LOW signal. The $\overline{\text{PPR}}$ indication is designed to be independent on the chip enable ($\overline{\text{EN}}$ -pin) input. When the internal open-drain FET is turned off, the $\overline{\text{PPR}}$ pin should leak less than 1 μ A current. When turned on, the $\overline{\text{PPR}}$ pin should be able to sink at least 10mA current under all operating conditions. The $\overline{\text{PPR}}$ pin can be used to drive an LED (see **Figure 1**) or worked as logic interface to a microprocessor (see **Figure 2**).

Power-Good Range

The input voltage is considered as power good when it meets the following three conditions:

1. $V_{IN} > V_{POR}$
2. $V_{IN} - V_{BAT} > V_{OS}$

The VOS is the offset voltage to determine if the battery voltage is even higher than the input voltage. All VPOR and VOS are realized with sufficient hysteresis, as given in the Electrical Specification table. All charging activities are disabled when the input voltage falls out of the power-good range.

Input and Output Comparator

Obviously, when the input source voltage is lower than the battery voltage, no charging activity could be started and the charger will disable the internal pass element to prevent battery leakage. Charge begins when the input voltage is higher than the battery voltage by a defined offset voltage (VOS). This scheme also ensures that the charger is completely turned off when the input power is removed from the charger.

CHG Indication

The \overline{CHG} pin is implemented as an open-drain output to give a logic LOW when a charge cycle begins and turn HIGH when an end-of-charge (EOC) condition is reached. This pin is designed with a sinking ability of more than 10mA so as to drive an LED. When the charger is disabled through \overline{EN} -pin, the \overline{CHG} outputs a high impedance. The \overline{CHG} pin can also be used to interface with a microprocessor.

 \overline{EN} Input

The chip is enabled by a logic LOW signal applied to the \overline{EN} pin. This pin is realized with a 200k Ω internal pull-down resistor such that even the \overline{EN} pin is left floating, the input is equivalent to logic LOW and the chip is enabled by default. Similarly, the chip is disabled when the \overline{EN} pin receives a logic HIGH signal. The threshold for HIGH is given in the ES (*Electrical Specifications*).

IMIN Indication

The IMIN pin can be used to program the End-of-Charge (EOC) current by connecting a resistor between this pin and the GND pin. The programming is defined by the following equation:

$$I_{MIN} \text{ (mA)} = 4180 / R_{IMIN}$$

Where R_{IMIN} is usually in k Ω .

IREF Pin

The IREF pin is for fast charge-current programming. By connecting a resistor between this pin and the GND pin, the fast charge current limit is determined by the following equation:

$$I_{CHG} \text{ (mA)} = 4400 / R_{IREF}$$

Where R_{IREF} is in k Ω . The actual charge current is guaranteed to have 10% accuracy of I_{CHG} with the charge current set at 150mA.

BAT pin

Always connect the BAT pin to a single-cell Li-ion/Polymer battery in parallel with a 1 μ F (or larger) X5R ceramic capacitor for decoupling and guaranteeing system stability. When the \overline{EN} pin is pulled to logic HIGH, the BAT output is disabled. The PT8A2803 relies on a battery for stability and is not guaranteed to be stable if the battery is not connected.

Dropout Voltage

When the input voltage is low while the battery voltage is high, the charging current may not be maintained according to the equation $I_{MIN} \text{ (mA)} = 4180 / R_{IMIN}$ due to a limited internal on-resistance ($R_{DS(ON)}$) of the internal pass element. The worst resistance of the pass FET is about 1.2 Ω at the maximum operating temperature, thus if tested with 500mA current and 4.2V battery voltage, constant current could still be maintained when the input voltage is below 4.62V.

Thermal Foldback

The bottom big exposed pad in DFN package is used for thermal foldback. For reducing the chip ambient temperature as much as possible, it is recommended to connect as much copper as possible to this pad either on the component layer or other layers through thermal vias. The thermal regulation function starts to reduce the charge current when the internal temperature reaches a typical value of 115 $^{\circ}$ C.

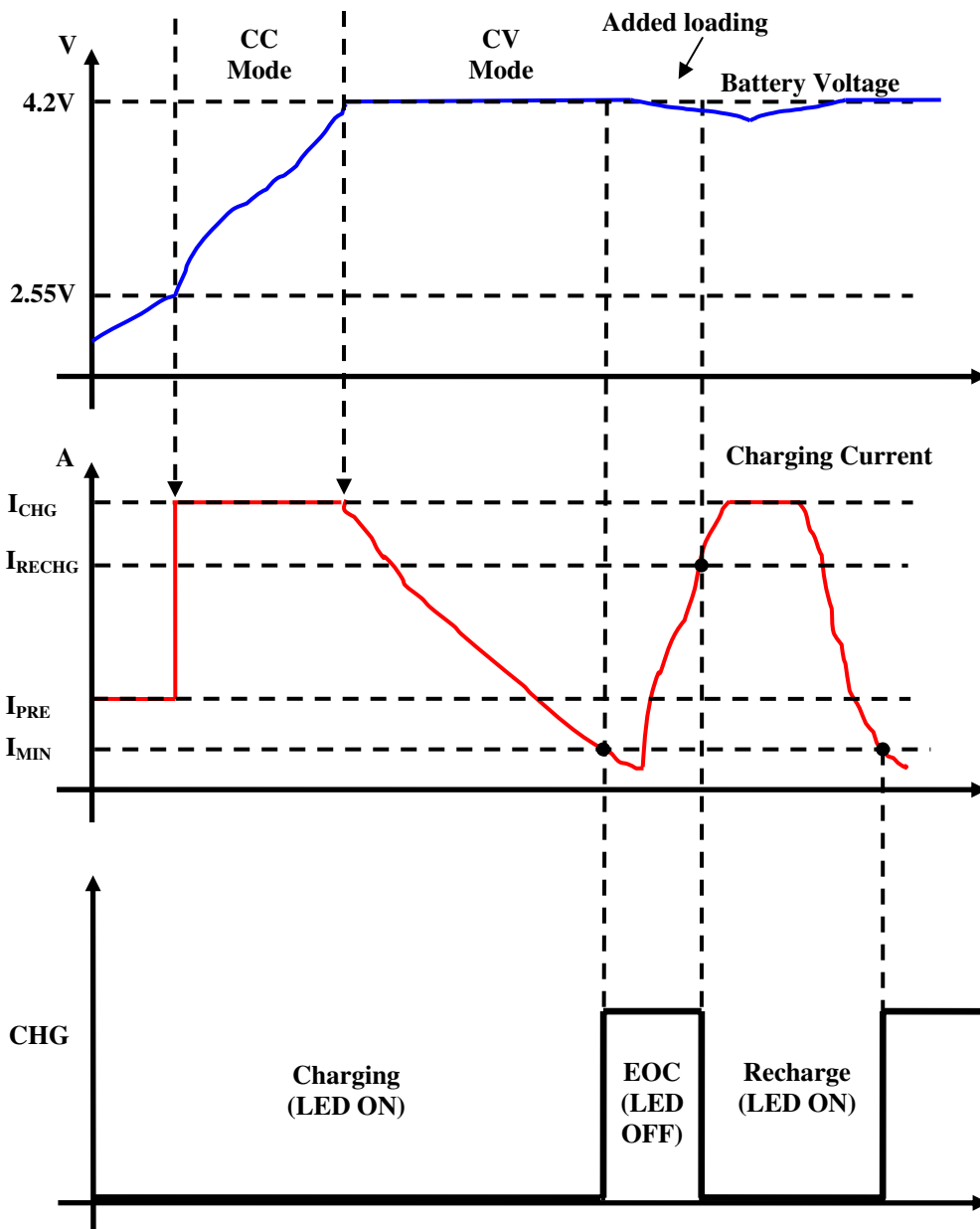

Figure 4 PT8A2803 Typical Charge Profile

Application Information

Input Capacitor Selection

The input capacitor is employed to decouple the power supply from load transients and suppress noise from power lines. Typically, a 1 μ F X5R ceramic capacitor is recommended to be placed very close between the VIN pin and GND pin to stabilize the operation during the start up, especially when the input supply is passing the POR threshold and the VIN-BAT comparator offset voltage. Once passing through the POR threshold, there is a voltage hysteresis to provide sufficient guard band from noise or load transient to trigger the system to reset.

Output Capacitor Selection

The criterion for selecting the output capacitor is to maintain the stability of the charger as well as to bypass any transient load current. Typically, a minimum capacitance of 1 μ F X5R ceramic capacitor is recommended and sufficient for stabilizing the system. For systems that may happen to occasionally see high load transients, the output capacitor may be increased to further bypass any ripples so caused.

Charge Current Limit

During the constant-current (CC) charging mode, the charging current is primarily determined by I_{CHG} as calculated in previous formula. However, the actual charge current in the CC mode could also be limited by other factors as described by below **Figure 5**. When the input (V_{IN}) and output (V_{BAT}) voltage are too close to each other, the on-resistance of the internal pass element may limit the amount of current that passes through it. For example, the solid curve describes a typical case in which the battery voltage is 4.0V and the charge current (I_{CHG}) is set at 350mA. When the input voltage is sufficiently higher than the battery voltage but has not increased the die temperature over the thermal limit yet, the charging current is accurately regulated at 350mA.

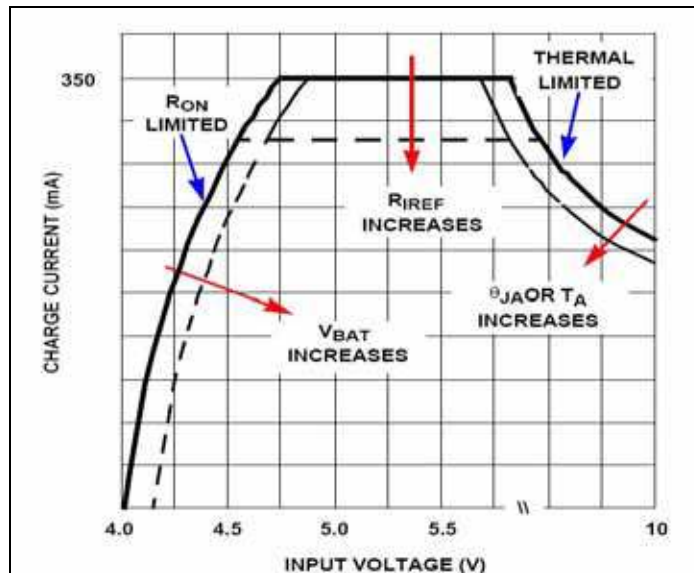

Figure 5: PT8A2803 Charge Current Limits In CC Mode

When the input voltage is reduced (or the battery voltage is increases towards the input voltage), the charge current is limited by the on-resistance of the pass element. Therefore, it is recommended to employ sufficiently high input voltage for applications that require constant charging current over the entire charging period. But for applications that needs to minimize the heat dissipation, a current-limiting adapter maybe applied to maintain constant charging current at whole charging phase.

In addition, if the input voltage increases, the charge current may also be reduced due to the thermal foldback function. The high voltage drop across the pass element increases the power dissipation therein and thus causing the die temperature to increase significantly.

Layout Guidance

The PT8A2803 employs thermally-enhanced DFN package, which have an exposed thermal pad at its bottom side. It is recommended to connect as much copper as possible between the exposed pad and PCB to make it effective in dissipating the heat away from the die. For applications requiring high charging current, the thermal impedance should be further reduced by employing more layers of copper to connect with the exposed pad through thermal via.

Input Power Sources

PT8A2803 works with different types of AC/DC adapter or USB port (any type) with no special requirements. For PT8A2803, it works with input voltage ranges from 4.3V to 5.5V for normal operation but the maximum input voltage is 7V.

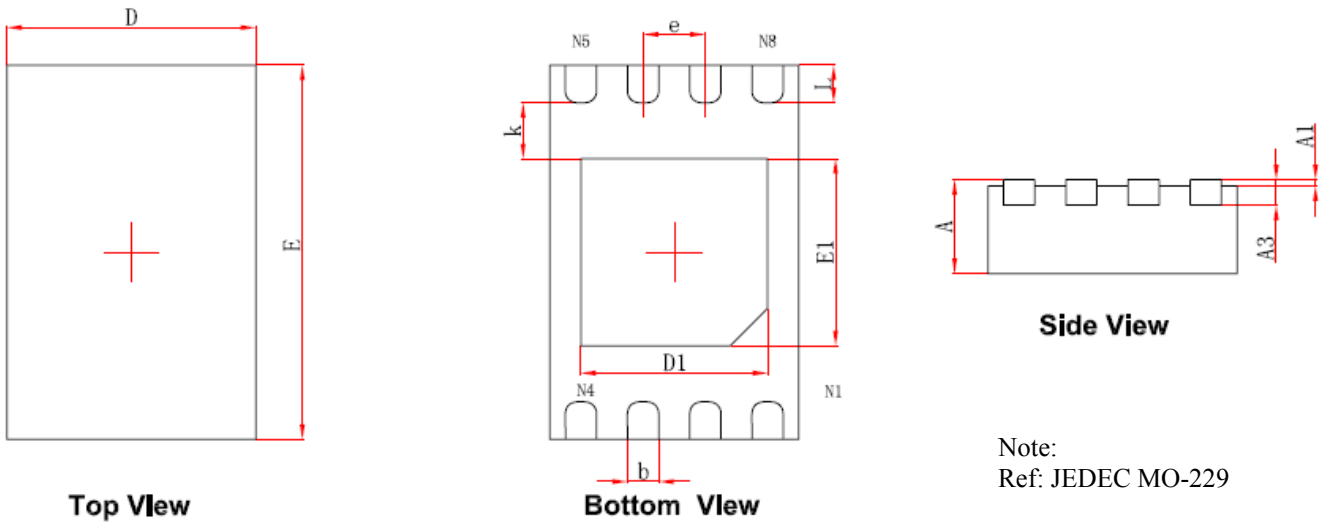
Mechanical Information
ZEE (Lead free and Green TDFN 2x3)

Symbol	Dimensions In Millimeters		Dimensions In Inches	
	Min	Max	Min	Max
A	0.700	0.800	0.028	0.035
A1	0.000	0.050	0.000	0.002
A3	0.203REF		0.008REF	
D	1.924	2.076	0.076	0.082
E	2.924	3.076	0.115	0.121
D1	1.400	1.600	0.005	0.063
E1	1.400	1.600	0.005	0.063
K	0.200MIN		0.008MIN	
b	0.200	0.300	0.008	0.012
e	0.500TYP		0.020TYP	
L	0.224	0.376	0.009	0.015

Ordering Information

Part Number	Package Code	Package
PT8A2803ZEE	ZE	Lead free and Green 8-pin TDFN 2x3

Notes:

- E = Pb-free and Green
- Adding X Suffix= Tape/Reel