

THIS DRAWING IS UNPUBLISHED. RELEASED FOR PUBLICATION
 © COPYRIGHT BY TYCO ELECTRONICS CORPORATION. ALL INTERNATIONAL RIGHTS RESERVED.

LOC	DIST	REVISIONS			
P	LTR	DESCRIPTION	DATE	DWN	APVD
AD	00	A1	REVISED PER ECO-08-016840	09JUL08	HMR WM

- 1 ALL CORNERS OR RADII TO BE .005 MAX.
- 2 NATURAL KNOB: BLACK INDICATOR LINE.
BLACK KNOB: WHITE INDICATOR LINE.
GOLD KNOB: RED INDICATOR LINE.
- 3 SETSCREWS: 303 STAINLESS STEEL, BLACK ANODIZED.
- 4 KNOB: 5056 ALUMINUM ALLOY, COLOR PER TABLE ANODIZED

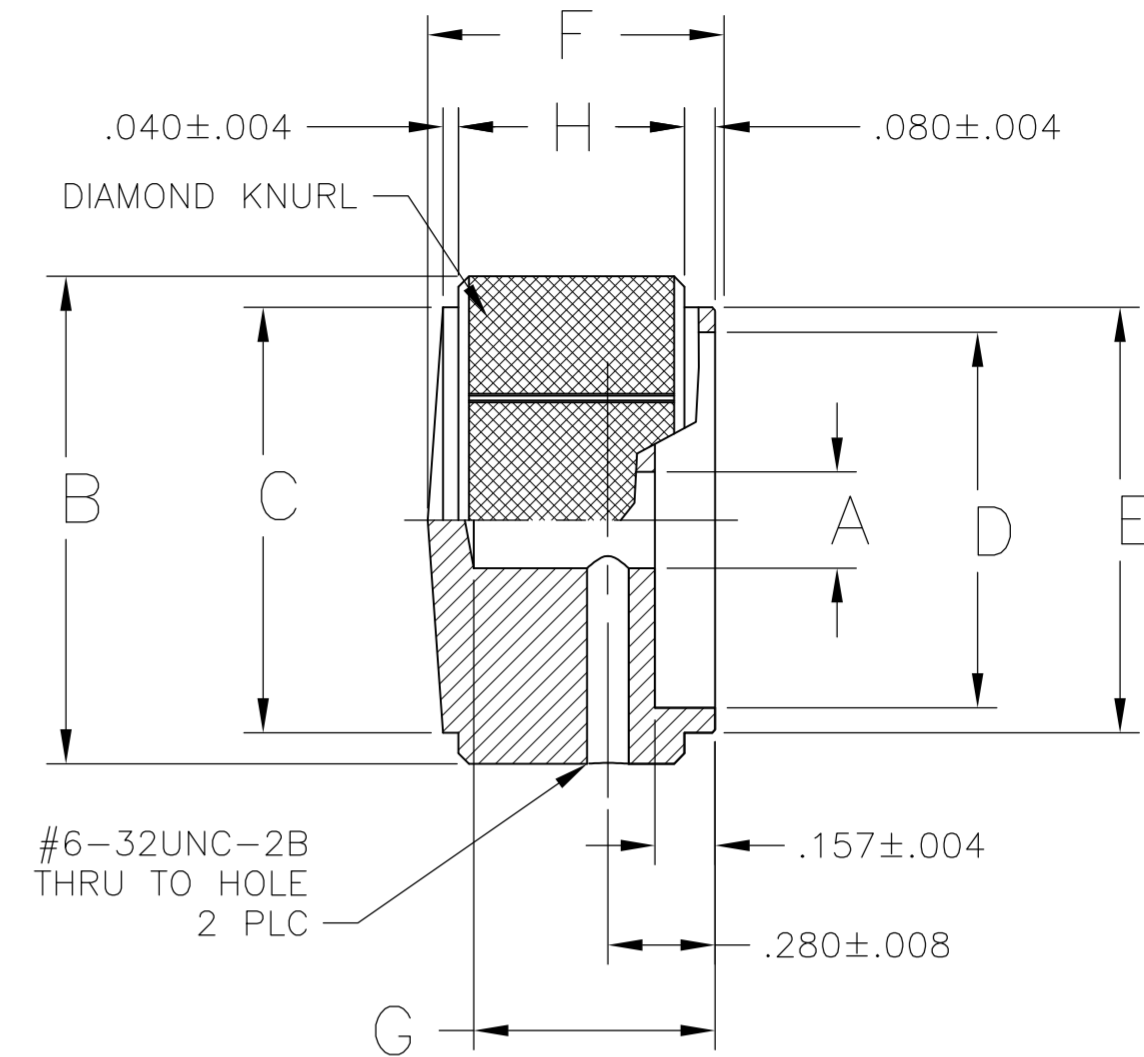
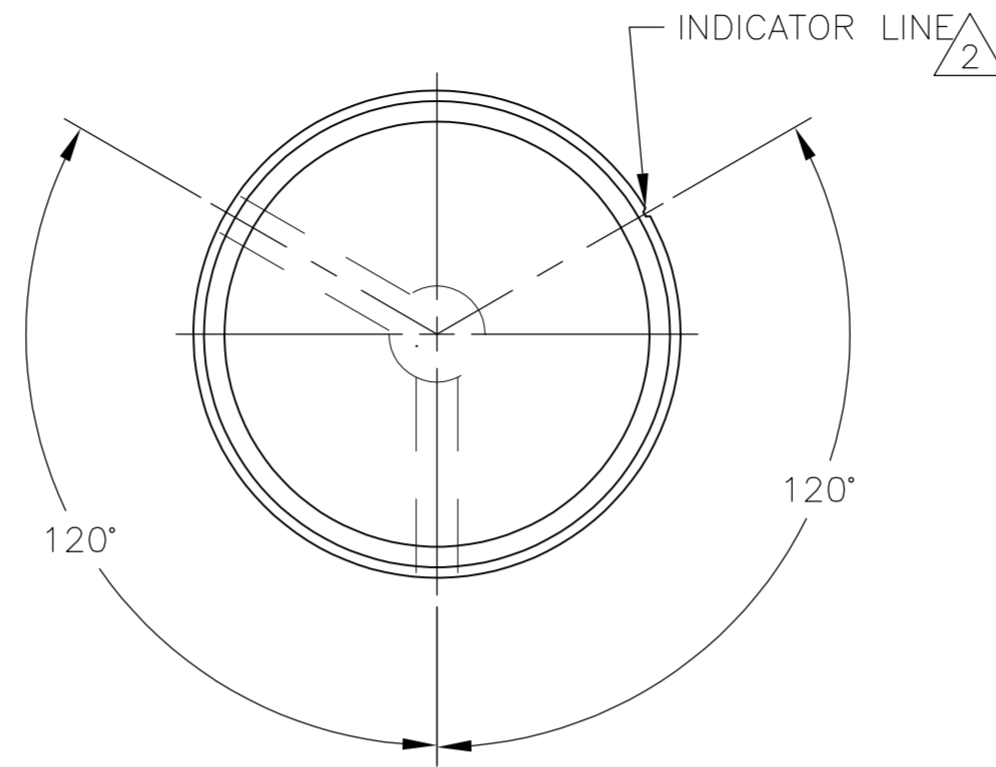

H	G	F	E	D	C	B	A SHAFT SIZE	SETSCREW	COLOR	ALCO MODEL NUMBER	TE PART NUMBER
.590±.008	.630±.008	.750±.012	1.110±.012	.980±.012	1.110±.012	1.272±.012	.251 ^{+.003} _{-.000}	#6-32 X .438	GOLD	KD1250G-1/4	-
									BLACK	KD1250B-1/4	6-1437621-9
									NATURAL	KD1250A-1/4	6-1437621-8
.470±.008	.510±.008	.630±.008	.820±.012	.710±.012	.820±.012	.970±.012		#6-32 X .313	GOLD	KD900G-1/4	-
									BLACK	KD900B-1/4	7-1437621-7
									NATURAL	KD900A-1/4	7-1437621-6
.470±.008	.510±.008	.630±.008	.660±.012	.590±.008	.660±.012	.770±.012		#6-32 X .188	GOLD	KD700G-1/4	-
									BLACK	KD700B-1/4	7-1437621-5
									NATURAL	KD700A-1/4	7-1437621-4
.470±.008	.510±.008	.630±.008	.430±.008	.380±.008	.430±.008	.520±.008	#6-32 X .125	GOLD	KD500G-1/4	-	
								BLACK	KD500B-1/4	7-1437621-2	
								NATURAL	KD500A-1/4	7-1437621-0	
.470±.008	.510±.008	.630±.008	.430±.008	.380±.008	.430±.008	.520±.008	#6-32 X .125	GOLD	KD500G-1/8	-	
								BLACK	KD500B-1/8	7-1437621-3	
								NATURAL	KD500A-1/8	7-1437621-1	

THIS DRAWING IS A CONTROLLED DOCUMENT.

DWN	M. BINNER	13JAN05
CHK	M. ZITTO	13JAN05
APVD	M. ZITTO	13JAN05

Tyco Electronics Corporation
Harrisburg, PA 17105-3608

NAME: KNOB, KD SERIES

SIZE	CAGE CODE	DRAWING NO	RESTRICTED TO
A2	00779	6-1437621-8	-

CUSTOMER DRAWING

SCALE: 1:1 SHEET: 1 of 1 REV: A1