

**THREAD-IN SHROUD 0.4MM**

**R222.550.701**

**SMOOTH DETENT**

Series : SMP

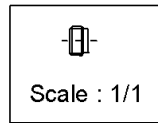
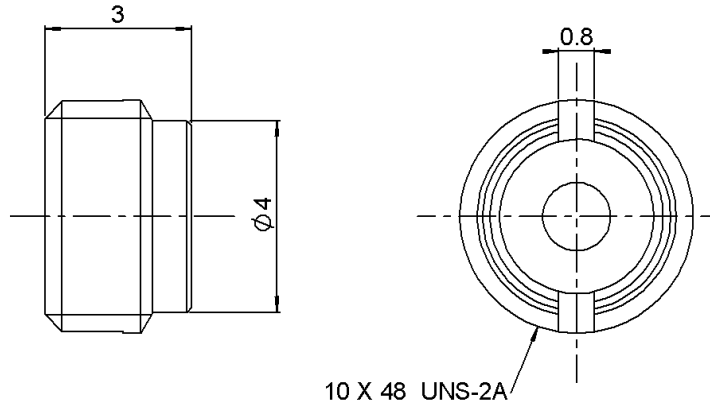

All dimensions are in mm.

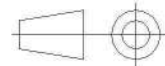

COMPONENTS	MATERIALS	PLATINGS (µm)
BODY	STAINLESS STEEL	PASSIVE .
CENTER CONTACT		
OUTER CONTACT		
INSULATOR		
GASKET		
OTHERS PARTS	-	-
-	-	-
-	-	-

Issue : 1243 B

In the effort to improve our products, we reserve the right to make changes judged to be necessary.



**THREAD-IN SHROUD 0.4MM**

**R222.550.701**

**SMOOTH DETENT**

Series : SMP

**PACKAGING**

**SPECIFICATION**

Standard	Unit	Other
<b>100</b>	<b>'W' option</b>	<b>Contact us</b>

**ELECTRICAL CHARACTERISTICS**

**ENVIRONMENTAL**

Impedance	NA	$\Omega$
Frequency	NA	GHz
VSWR	NA + <b>0,0000</b>	x F(GHz) Maxi
Insertion loss	NA	$\sqrt{F}$ (GHz) dB Maxi
RF leakage	NA - (	F(GHz)) dB Maxi
Voltage rating	NA	Veff Maxi
Dielectric withstanding voltage	NA	Veff mini
Insulation resistance	NA	M $\Omega$ mini

Operating temperature	<b>-65/+165</b>	$^{\circ}$ C
Hermetic seal	NA	Atm.cm3/s
Panel leakage		

**OTHERS CHARACTERISTICS**

Assembly instruction

Others :

**MECHANICAL CHARACTERISTICS**

Center contact retention		
Axial force – Mating end	NA	N mini
Axial force – Opposite end	NA	N mini
Torque	NA	N.cm mini
Recommended torque		
Mating	NA	N.cm
Panel nut	<b>90</b>	N.cm
Mating life	<b>1000</b>	Cycles mini
Weight	<b>0,1500</b>	g

Issue : 1243 B

In the effort to improve our products, we reserve the right to make changes judged to be necessary.



**THREAD-IN SHROUD 0.4MM**

**R222.550.701**

**SMOOTH DETENT**

Series : SMP

**ADDITIONAL INFORMATIONS  
MOUNTING AND REPLACEMENT INSTRUCTIONS**

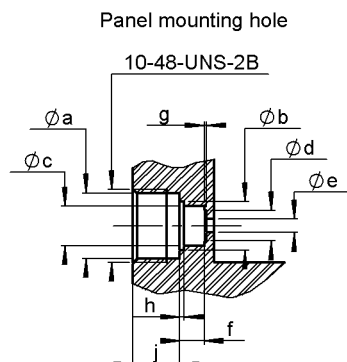

	mini - maxi
a	4,32 - 4,37
b	3,21 - 3,25
c	2,56 - 2,58
d	1,95 - 2,05
e	0,86 - 0,89
f	1,61 - 1,65
g	0,13 - 0,18
h	0,28 - 0,35
i	3,10 - 3,15

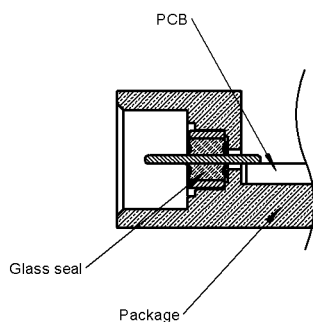

1. Solder the glass seal on the panel.
2. Connector must be screwed or unscrewed with adapted torque driver R282.339.001 (recommended coupling torque 90 Ncm)  
Alignment tool R282.360.001
3. Slide on the receptacle until it bottoms against tooling

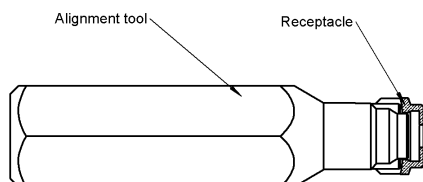

1. Screw the receptacle into the package housing until activation of the torque driver

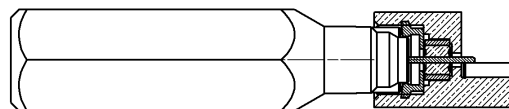

2. Withdraw the alignment tool

Issue : 1243 B

In the effort to improve our products, we reserve the right to make changes judged to be necessary.

