

## Description

The ZTL431 and ZTL432 are three terminal adjustable shunt regulators offering excellent temperature stability and output current handling capability up to 100mA. The output voltage may be set to any chosen voltage between 2.5 and 20 volts by selection of two external divider resistors.

The devices can be used as a replacement for zener diodes in many applications requiring an improvement in zener performance.

The ZTL432 has the same electrical specifications as the ZTL431 but has a different pin out in SOT23 (F-suffix) and SOT23F (FF-suffix).

Both variants are available in two grades with initial tolerances of 1% and 0.5% for the A and B grades, respectively.

These are functionally equivalent to the TL431/TL432 except for maximum operation voltage, and have an ambient temperature range of -40°C to +125°C as standard.

## Features

- Temperature Range ..... -40°C to +125°C
- Reference Voltage Tolerance at +25°C
  - 0.5%.....B grade
  - 1% .....A grade
- 0.2Ω Typical Output Impedance
- Sink Current Capability..... 1mA to 100mA
- Adjustable Output Voltage.....V<sub>REF</sub> to 20V
- **Totally Lead-Free & Fully RoHS Compliant (Notes 1 & 2)**
- **Halogen and Antimony Free. "Green" Device (Note 3)**
- **An Automotive-Compliant Part is Available Under Separate Datasheet ([ZTL431AQ](#), [ZTL431BQ](#), [ZTL432AQ](#), [ZTL432BQ](#))**

## Applications

- Opto-Coupler Linearization
- Linear Regulators
- Improved Zener
- Variable Reference

Notes: 1. No purposely added lead. Fully EU Directive 2002/95/EC (RoHS) & 2011/65/EU (RoHS 2) compliant.  
 2. See [http://www.diodes.com/quality/lead\\_free.html](http://www.diodes.com/quality/lead_free.html) for more information about Diodes Incorporated's definitions of Halogen and Antimony-free, "Green" and Lead-free.  
 3. Halogen- and Antimony-free "Green" products are defined as those which contain <900ppm bromine, <900ppm chlorine (<1500ppm total Br + Cl) and <1000ppm antimony compounds.

## Pin Assignments

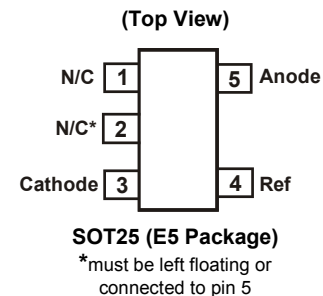
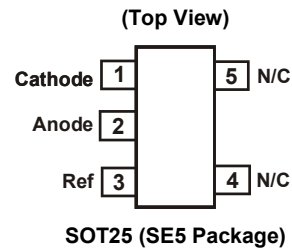
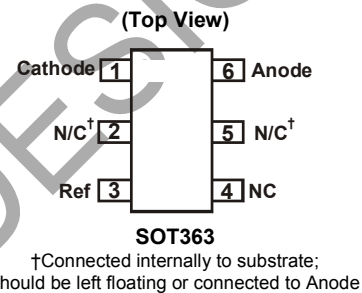
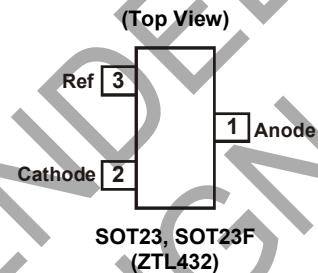
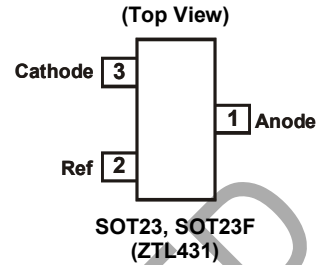

**Absolute Maximum Ratings** (Voltages specified are relative to the Anode pin unless otherwise stated.)

Parameter	Rating	Unit
Cathode Voltage ( $V_{KA}$ )	20	V
Continuous Cathode Current ( $I_{KA}$ )	150	mA
Reference Input Current Range ( $I_{REF}$ )	-50 $\mu$ A to +10mA	—
Operating Junction Temperature	-40 to +150	$^{\circ}$ C
Storage Temperature	-55 to +150	$^{\circ}$ C

Operation above the absolute maximum rating may cause device failure.  
 Operation at the absolute maximum ratings, for extended periods, may reduce device reliability.

**Package Thermal Data**

Package	$\theta_{JA}$	$P_{Dis}$ $T_A = +25^{\circ}$ C, $T_J = +150^{\circ}$ C
SOT23	380 $^{\circ}$ C/W	330mW
SOT23F	138 $^{\circ}$ C/W	900mW
SOT25	250 $^{\circ}$ C/W	500mW
SOT363	380 $^{\circ}$ C/W	330mW

**Recommended Operating Conditions** (@ $T_A = +25^{\circ}$ C, unless otherwise specified.)

Symbol	Parameter	Min	Max	Unit
$V_{KA}$	Cathode Voltage	$V_{REF}$	20	V
$I_{KA}$	Cathode Current	1	100	mA
$T_A$	Operating Ambient Temperature Range	-40	+125	$^{\circ}$ C

**Electrical Characteristics** (@ $T_A = +25^{\circ}$ C, unless otherwise specified.)

Symbol	Parameter	Conditions	Min	Typ	Max	Unit
$V_{REF}$	Reference Voltage	$V_{KA} = V_{REF}$ $I_{KA} = 10$ mA	ZTL43_A 2.475	2.5	2.525	V
			ZTL43_B 2.487	2.5	2.513	
$V_{DEV}$	Deviation of Reference Voltage Over Full Temperature Range	$V_{KA} = V_{REF}$ $I_{KA} = 10$ mA	$T_A = 0$ to +70 $^{\circ}$ C —	6	16	mV
			$T_A = -40$ to +85 $^{\circ}$ C —	14	34	
			$T_A = -40$ to +125 $^{\circ}$ C —	14	34	
$\frac{\Delta V_{REF}}{\Delta V_{KA}}$	Ratio of Change In Reference Voltage To the Change In Cathode Voltage	$I_{KA} = 10$ mA	$V_{KA} = V_{REF}$ to 10V —	-1.4	-2.7	mV/V
			$V_{KA} = 10$ V to 20V —	-1.0	-2.0	
$I_{REF}$	Reference Input Current	$I_{KA} = 10$ mA, $R_1 = 10$ k $\Omega$ , $R_2 = O/C$ (Open Circuit)	—	2	4	$\mu$ A
$\Delta I_{REF}$	$I_{REF}$ Deviation Over Full Temperature Range	$I_{KA} = 10$ mA $R_1 = 10$ k $\Omega$ $R_2 = O/C$ (Open Circuit)	$T_A = 0$ to +70 $^{\circ}$ C —	0.8	1.2	$\mu$ A
			$T_A = -40$ to +85 $^{\circ}$ C —	0.8	2.5	
			$T_A = -40$ to +125 $^{\circ}$ C —	0.8	2.5	
$I_{KA(MIN)}$	Minimum Cathode Current for Regulation	$V_{KA} = V_{REF}$	—	0.4	0.6	mA
$I_{KA(OFF)}$	Off State Current	$V_{KA} = 20$ V, $V_{REF} = 0$ V	—	0.1	0.5	$\mu$ A
$R_Z$	Dynamic Output Impedance	$V_{KA} = V_{REF}$ , $f = 0$ Hz	—	0.2	0.5	$\Omega$

**Typical Characteristics**

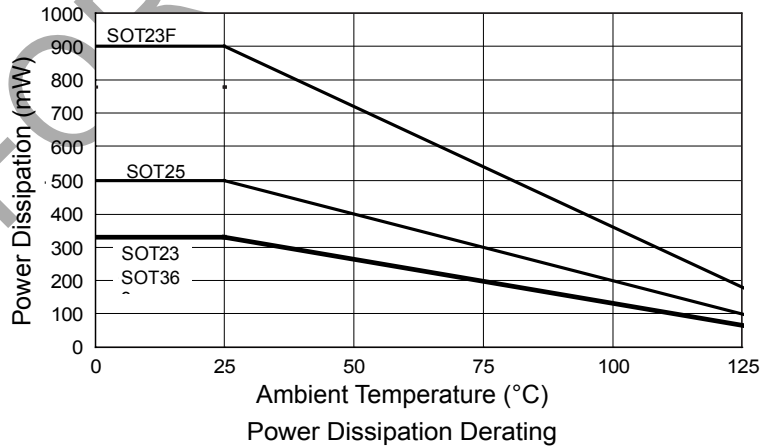
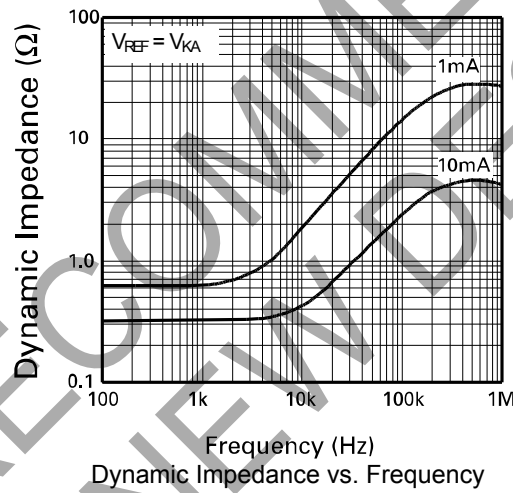
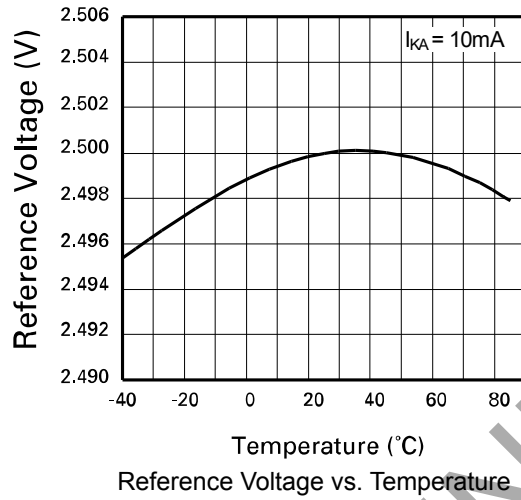

**Typical Characteristics (Cont.)**

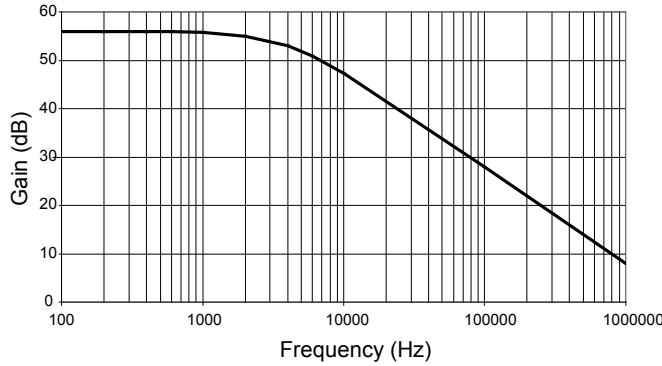

Gain vs. Frequency

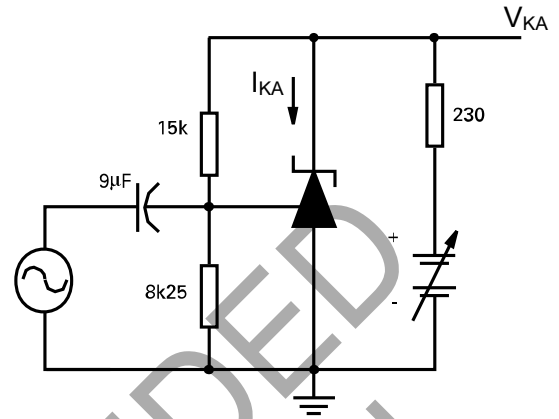

$I_{KA} = 10\text{mA}$ ,  $T_A = 25^\circ\text{C}$

Test Circuit for Open Loop Voltage Gain

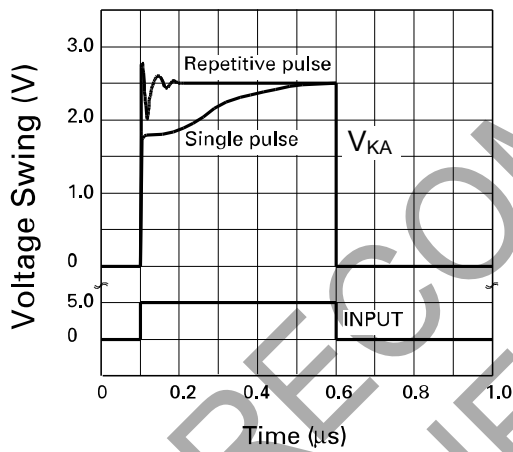

Pulse Response

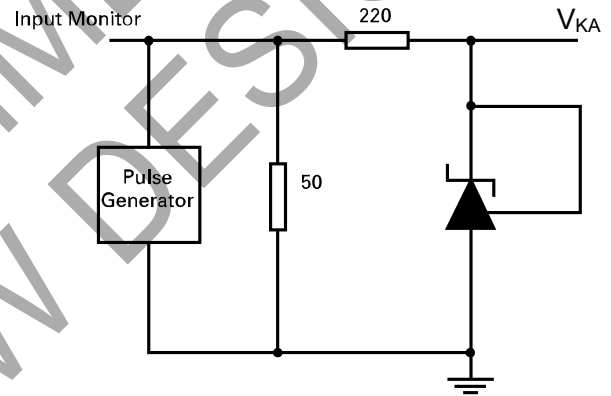

$T_A = 25^\circ\text{C}$

Test Circuit for Pulse Response

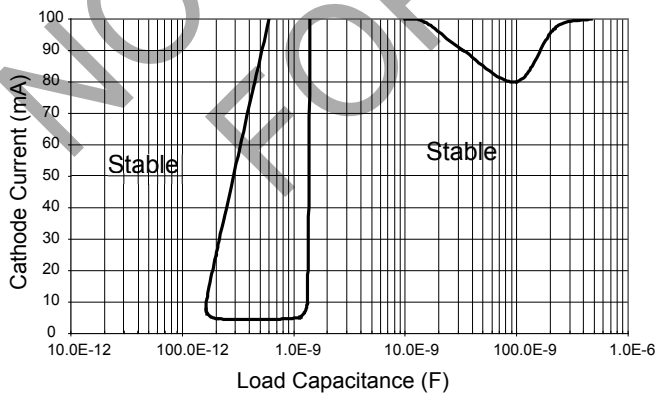

Stability Boundary Condition

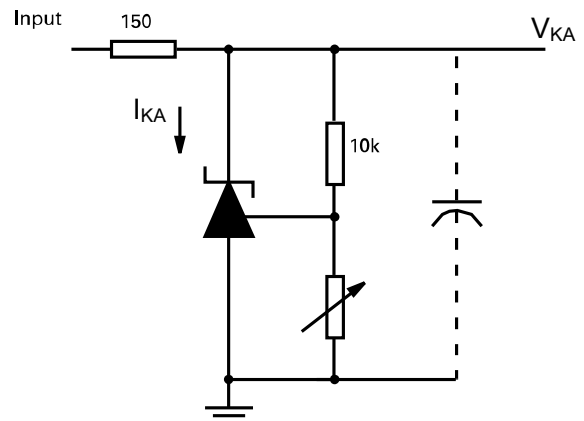

$V_{REF} < V_{KA} < 20\text{V}$ ,  $I_{KA} = 10\text{mA}$ ,  $T_A = +25^\circ\text{C}$   
Test Circuit for Stability Boundary Conditions

**Application Circuits**

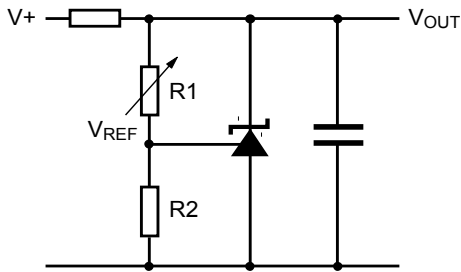

$$V_{OUT} = \left(1 + \frac{R1}{R2}\right) V_{REF}$$

Shunt regulator

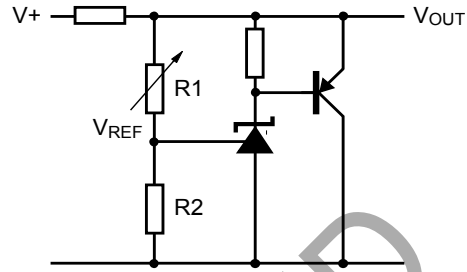

$$V_{OUT} = \left(1 + \frac{R1}{R2}\right) V_{REF}$$

Higher current shunt regulator

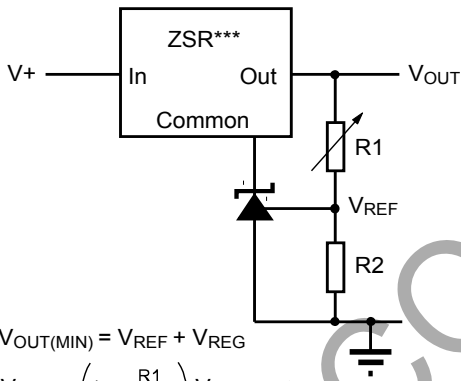

$$V_{OUT(MIN)} = V_{REF} + V_{REG}$$

$$V_{OUT} = \left(1 + \frac{R1}{R2}\right) V_{REF}$$

Output control of a three terminal fixed regulator

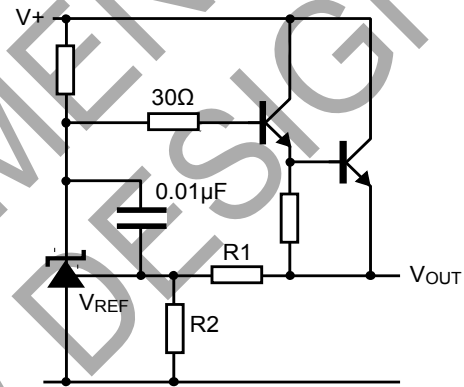

$$V_{OUT} = \left(1 + \frac{R1}{R2}\right) V_{REF}$$

Series regulator

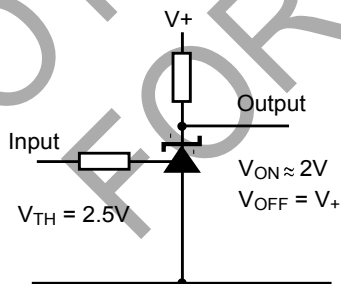

Single supply comparator with temperature compensated threshold

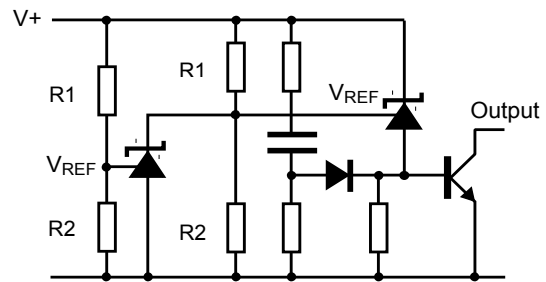

$$\text{Low limit} = \left(1 + \frac{R1B}{R2B}\right) V_{REF}$$

$$\text{High limit} = \left(1 + \frac{R1A}{R2A}\right) V_{REF}$$

Over voltage / under voltage protection circuit

**DC Test Circuits**

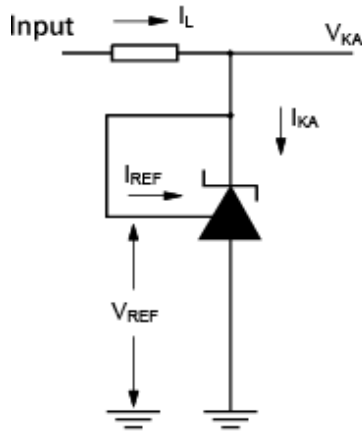

Figure 1. Test circuit for  $V_{KA} = V_{REF}$

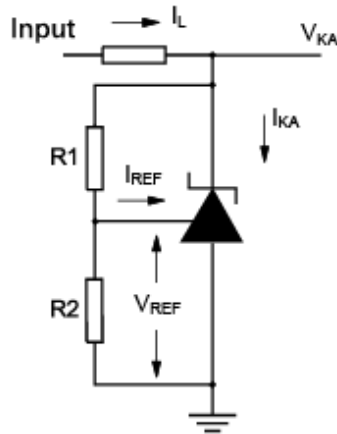

Figure 2. Test circuit for  $V_{KA} > V_{REF}$

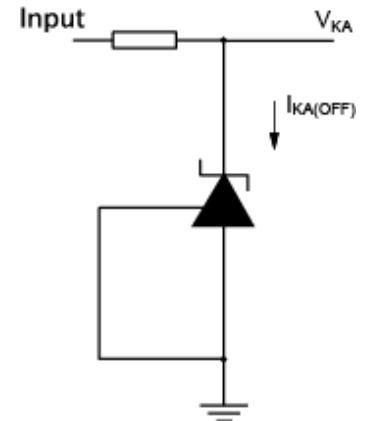

Figure 3. Test circuit for off state current

**Notes**

Deviation of reference input voltage,  $V_{DEV}$ , is defined as the maximum variation of the reference input voltage over the full temperature range.

The average temperature coefficient of the reference input voltage,  $V_{REF}$  is defined as:

$$V_{REF}(ppm/^{\circ}C) = \frac{V_{DEV} \times 1,000,000}{V_{REF}(T1-T2)}$$

The dynamic output impedance,  $R_z$ , is defined as:

$$R_z = \frac{\Delta V_z}{\Delta I_z}$$

When the device is programmed with two external resistors,  $R1$  and  $R2$ , (Figure 2), the dynamic output impedance of the overall circuit,  $R'_z$ , is defined as:

$$R'_z = R_z \left(1 + \frac{R1}{R2}\right)$$

**Stability Boundary**

The ZTL431 and ZTL432 are stable with a range of capacitive loads. A zone of instability exists as demonstrated in the typical characteristic graph on page 4. The graph shows typical conditions. To ensure reliable stability, a capacitor of 4.7nF or greater is recommended between anode and cathode.

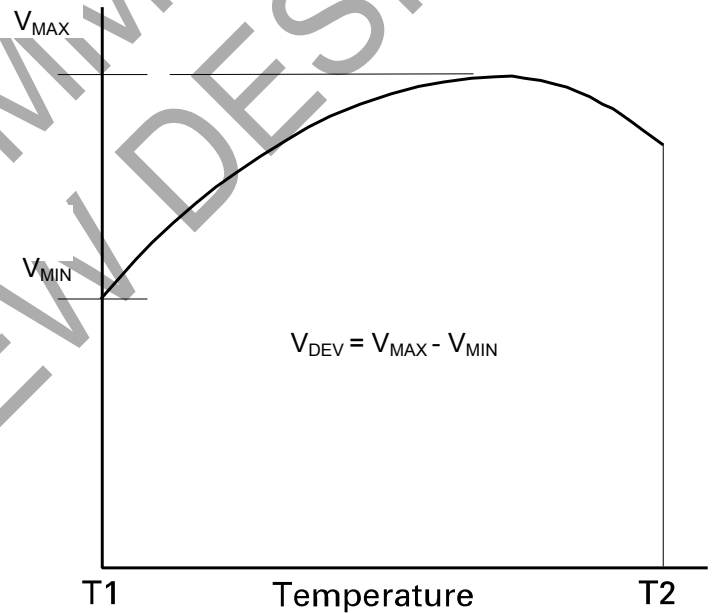

**Ordering Information**

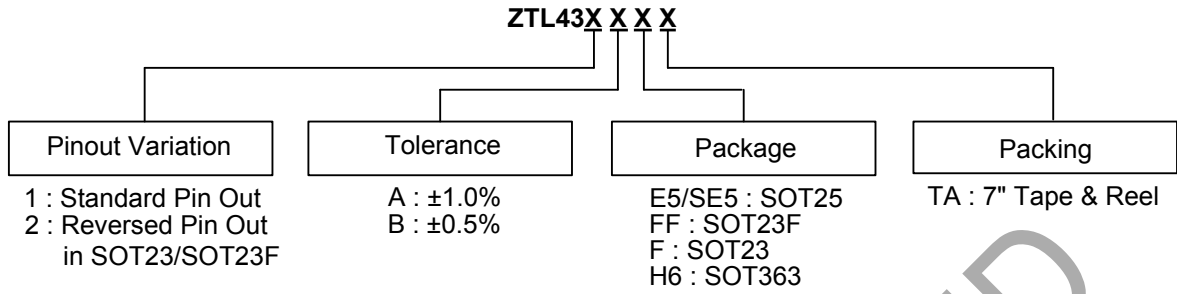

Tol.	Part Number	Package	Part Mark	Status	Reel Size	Tape Width (mm)	Quantity per Reel
1%	ZTL431AE5TA	SOT25	31A	Active	7", 180mm	8	3,000
	ZTL431AFFTA	SOT23F	31A	Active	7", 180mm	8	3,000
	ZTL431AFTA	SOT23	31A	Active	7", 180mm	8	3,000
	ZTL431AH6TA	SOT363	31A	Active	7", 180mm	8	3,000
	ZTL431ASE5TA	SOT25	S2A	Active	7", 180mm	8	3,000
	ZTL432AFFTA	SOT23F	32A	Active	7", 180mm	8	3,000
0.5%	ZTL432AFTA	SOT23	32A	Active	7", 180mm	8	3,000
	ZTL431BE5TA	SOT25	31B	Active	7", 180mm	8	3,000
	ZTL431BFFTA	SOT23F	31B	Active	7", 180mm	8	3,000
	ZTL431BFTA	SOT23	31B	Active	7", 180mm	8	3,000
	ZTL431BH6TA	SOT363	31B	Active	7", 180mm	8	3,000
	ZTL432BFFTA	SOT23F	32B	Active	7", 180mm	8	3,000
	ZTL432BFTA	SOT23	32B	Active	7", 180mm	8	3,000

NOT RECOMMENDED FOR NEW DESIGN

**Marking Information**

(1) SOT23 and SOT23F

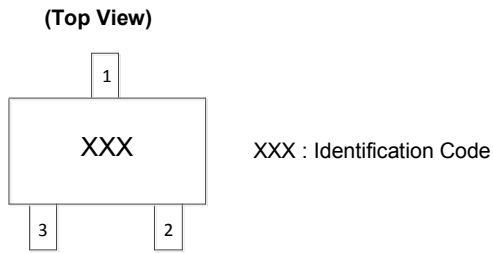

Part Number	Identification Code
ZTL431AFFTA	31A
ZTL431AFTA	31A
ZTL432AFFTA	32A
ZTL432AFTA	32A
ZTL431BFFTA	31B
ZTL431BFTA	31B
ZTL432BFFTA	32B
ZTL432BFTA	32B

(2) SOT25

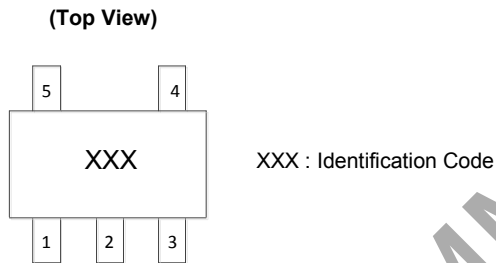

Part Number	Identification Code
ZTL431AE5TA	31A
ZTL431ASE5TA	S2A
ZTL431BE5TA	31B

(3) SOT363

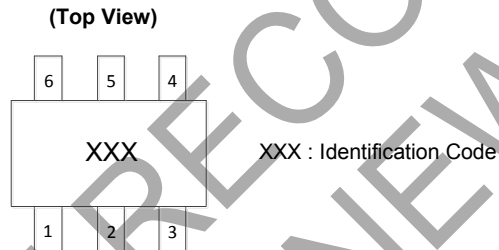

Part Number	Identification Code
ZTL431AH6TA	31A
ZTL431BH6TA	31B

NOT RECOMMENDED FOR NEW DESIGN



**Package Outline Dimensions**

Please see <http://www.diodes.com/package-outlines.html> for the latest version.

(1) Package Type: SOT23

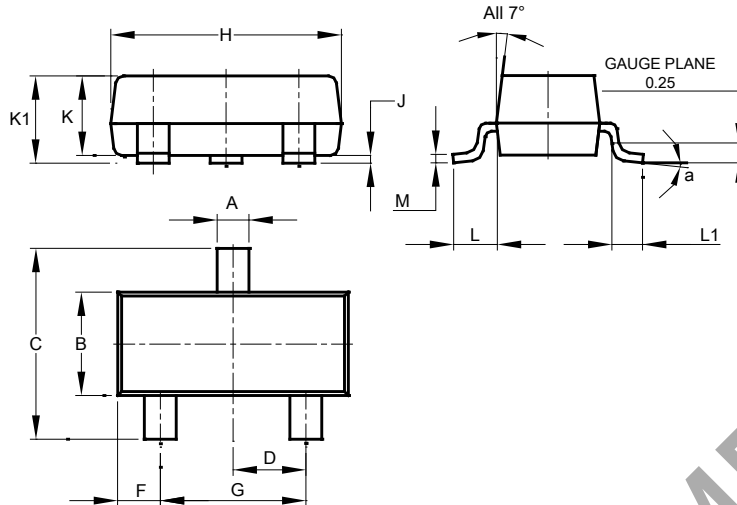

SOT23			
Dim	Min	Max	Typ
A	0.37	0.51	0.40
B	1.20	1.40	1.30
C	2.30	2.50	2.40
D	0.89	1.03	0.915
F	0.45	0.60	0.535
G	1.78	2.05	1.83
H	2.80	3.00	2.90
J	0.013	0.10	0.05
K	0.890	1.00	0.975
K1	0.903	1.10	1.025
L	0.45	0.61	0.55
L1	0.25	0.55	0.40
M	0.085	0.150	0.110
a	0°	8°	--
All Dimensions in mm			

(2) Package Type: SOT23F

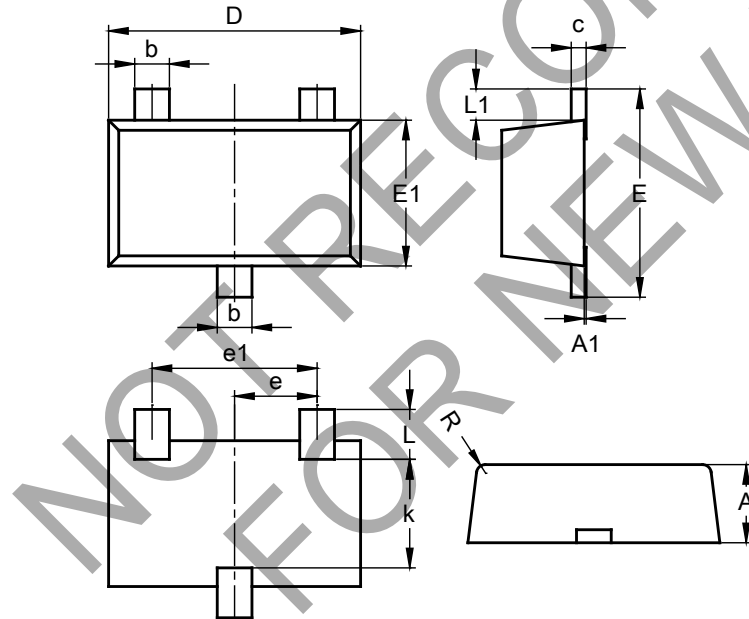

SOT23F			
Dim	Min	Max	Typ
A	0.80	1.00	0.90
A1	0.00	0.10	0.01
b	0.35	0.50	0.44
c	0.10	0.20	0.16
D	2.80	3.00	2.90
e	0.95 REF		
e1	1.90 REF		
E	2.30	2.50	2.40
E1	1.50	1.70	1.65
k	1.20	-	-
L	0.30	0.65	0.50
L1	0.30	0.50	0.40
R	0.05	0.15	-
All Dimensions in mm			

**Package Outline Dimensions (Cont.)**

Please see <http://www.diodes.com/package-outlines.html> for the latest version.

**(3) Package Type: SOT363**

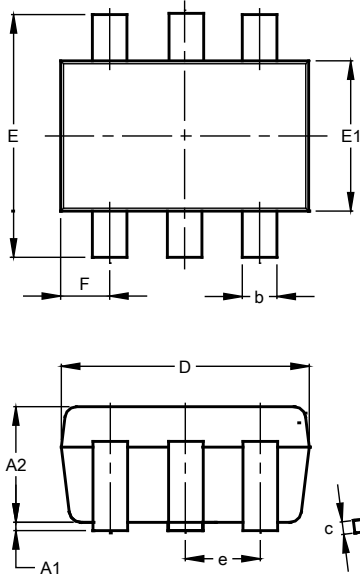

SOT363			
Dim	Min	Max	Typ
A1	0.00	0.10	0.05
A2	0.90	1.00	1.00
b	0.10	0.30	0.25
c	0.10	0.22	0.11
D	1.80	2.20	2.15
E	2.00	2.20	2.10
E1	1.15	1.35	1.30
e	0.650 BSC		
F	0.40	0.45	0.425
L	0.25	0.40	0.30
a	0°	8°	--
All Dimensions in mm			

**(4) Package Type: SOT25**

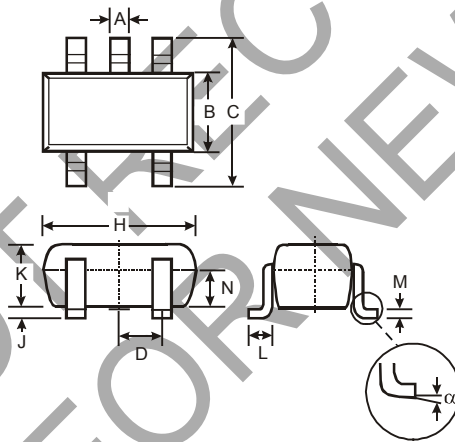

SOT25			
Dim	Min	Max	Typ
A	0.35	0.50	0.38
B	1.50	1.70	1.60
C	2.70	3.00	2.80
D	-	-	0.95
H	2.90	3.10	3.00
J	0.013	0.10	0.05
K	1.00	1.30	1.10
L	0.35	0.55	0.40
M	0.10	0.20	0.15
N	0.70	0.80	0.75
α	0°	8°	-
All Dimensions in mm			

## Suggested Pad Layout

Please see <http://www.diodes.com/package-outlines.html> for the latest version.

### (1) Package Type: SOT23

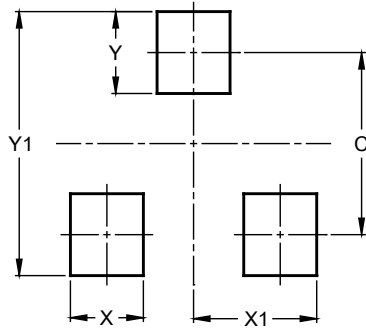

Dimensions	Value (in mm)
C	2.0
X	0.8
X1	1.35
Y	0.9
Y1	2.9

### (2) Package Type: SOT23F

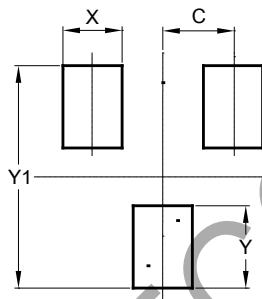

Dimensions	Value (in mm)
C	0.95
X	0.80
Y	1.110
Y1	3.000

### (3) Package Type: SOT363

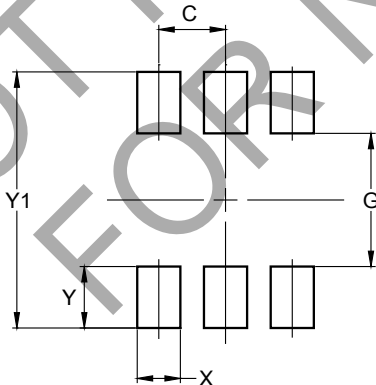

Dimensions	Value (in mm)
C	0.650
G	1.300
X	0.420
Y	0.600
Y1	2.500

**Suggested Pad Layout (Cont.)**

Please see <http://www.diodes.com/package-outlines.html> for the latest version.

(4) Package Type: SOT25

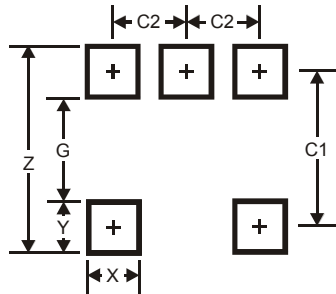

Dimensions	Value
Z	3.20
G	1.60
X	0.55
Y	0.80
C1	2.40
C2	0.95

NOT RECOMMENDED FOR NEW DESIGN

**IMPORTANT NOTICE**

1. DIODES INCORPORATED AND ITS SUBSIDIARIES ("DIODES") MAKE NO WARRANTY OF ANY KIND, EXPRESS OR IMPLIED, WITH REGARDS TO ANY INFORMATION CONTAINED IN THIS DOCUMENT, INCLUDING, BUT NOT LIMITED TO, THE IMPLIED WARRANTIES OF MERCHANTABILITY, FITNESS FOR A PARTICULAR PURPOSE OR NON-INFRINGEMENT OF THIRD PARTY INTELLECTUAL PROPERTY RIGHTS (AND THEIR EQUIVALENTS UNDER THE LAWS OF ANY JURISDICTION).
2. The Information contained herein is for informational purpose only and is provided only to illustrate the operation of Diodes products described herein and application examples. Diodes does not assume any liability arising out of the application or use of this document or any product described herein. This document is intended for skilled and technically trained engineering customers and users who design with Diodes products. Diodes products may be used to facilitate safety-related applications; however, in all instances customers and users are responsible for (a) selecting the appropriate Diodes products for their applications, (b) evaluating the suitability of the Diodes products for their intended applications, (c) ensuring their applications, which incorporate Diodes products, comply the applicable legal and regulatory requirements as well as safety and functional-safety related standards, and (d) ensuring they design with appropriate safeguards (including testing, validation, quality control techniques, redundancy, malfunction prevention, and appropriate treatment for aging degradation) to minimize the risks associated with their applications.
3. Diodes assumes no liability for any application-related information, support, assistance or feedback that may be provided by Diodes from time to time. Any customer or user of this document or products described herein will assume all risks and liabilities associated with such use, and will hold Diodes and all companies whose products are represented herein or on Diodes' websites, harmless against all damages and liabilities.
4. Products described herein may be covered by one or more United States, international or foreign patents and pending patent applications. Product names and markings noted herein may also be covered by one or more United States, international or foreign trademarks and trademark applications. Diodes does not convey any license under any of its intellectual property rights or the rights of any third parties (including third parties whose products and services may be described in this document or on Diodes' website) under this document.
5. Diodes products are provided subject to Diodes' Standard Terms and Conditions of Sale (<https://www.diodes.com/about/company/terms-and-conditions/terms-and-conditions-of-sales/>) or other applicable terms. This document does not alter or expand the applicable warranties provided by Diodes. Diodes does not warrant or accept any liability whatsoever in respect of any products purchased through unauthorized sales channel.
6. Diodes products and technology may not be used for or incorporated into any products or systems whose manufacture, use or sale is prohibited under any applicable laws and regulations. Should customers or users use Diodes products in contravention of any applicable laws or regulations, or for any unintended or unauthorized application, customers and users will (a) be solely responsible for any damages, losses or penalties arising in connection therewith or as a result thereof, and (b) indemnify and hold Diodes and its representatives and agents harmless against any and all claims, damages, expenses, and attorney fees arising out of, directly or indirectly, any claim relating to any noncompliance with the applicable laws and regulations, as well as any unintended or unauthorized application.
7. While efforts have been made to ensure the information contained in this document is accurate, complete and current, it may contain technical inaccuracies, omissions and typographical errors. Diodes does not warrant that information contained in this document is error-free and Diodes is under no obligation to update or otherwise correct this information. Notwithstanding the foregoing, Diodes reserves the right to make modifications, enhancements, improvements, corrections or other changes without further notice to this document and any product described herein. This document is written in English but may be translated into multiple languages for reference. Only the English version of this document is the final and determinative format released by Diodes.
8. Any unauthorized copying, modification, distribution, transmission, display or other use of this document (or any portion hereof) is prohibited. Diodes assumes no responsibility for any losses incurred by the customers or users or any third parties arising from any such unauthorized use.

Copyright © 2021 Diodes Incorporated

[www.diodes.com](http://www.diodes.com)