

TO-220



ITO-220



Pin Definition:

1. Gate
2. Drain
3. Source

PRODUCT SUMMARY

V_{DS} (V)	$R_{DS(on)}$ (Ω)(max)	I_D (A)
600	0.75 @ $V_{GS}=10V$	10

Features

- Advanced high dense cell design.
- High Power and Current handling capability.

Application

- Power Supply.
- Lighting.

Ordering Information

Part No.	Package	Packing
TSM10N60CZ C0	TO-220	50pcs / Tube
TSM10N60CI C0	ITO-220	50pcs / Tube

Block Diagram

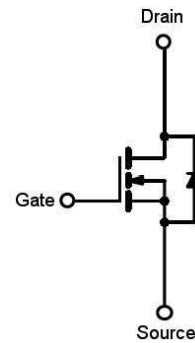

N-Channel MOSFET

Absolute Maximum Rating ($T_C = 25^\circ C$ unless otherwise noted)

Parameter	Symbol	Limit		Unit
		TO-220	ITO-220	
Drain-Source Voltage	V_{DS}	600		V
Gate-Source Voltage	V_{GS}	± 30		V
Continuous Drain Current	I_D^a	$T_C = 25^\circ C$		A
		$T_C = 100^\circ C$		
Pulsed Drain Current ^b	I_{DM}^a	40		A
Total Power Dissipation @ $T_C=25C$	P_{DTOT}	166	50	W
Single Pulsed Avalanche Energy ^c	E_{AS}	41		mJ
Operating Junction and Storage Temperature Range	T_J, T_{STG}	- 55 to +150		$^\circ C$

Thermal Performance

Parameter	Symbol	Limit		Unit
Junction to Case Thermal Resistance	$R_{\theta JC}$	0.75	2.5	$^\circ C/W$
Junction to Ambient Thermal Resistance	$R_{\theta JA}$	63		$^\circ C/W$

Notes a: Current limited by package

Notes b: Pulse width limited by the Maximum junction temperature

Notes c: $L=0.75mH, I_{AS}=10A, V_{DD}=50V, R_G=25\Omega, \text{Starting } T_J=25^\circ C$

Specifications (Ta = 25°C unless otherwise noted)

Parameter	Conditions	Symbol	Min	Typ	Max	Unit
Static^a						
Drain-Source Breakdown Voltage	$V_{GS} = 0V, I_D = 250\mu A$	BV_{DSS}	600	--	--	V
Gate Threshold Voltage	$V_{DS} = V_{GS}, I_D = 250\mu A$	$V_{GS(TH)}$	2	3.1	4	V
Gate Body Leakage	$V_{GS} = \pm 30V, V_{DS} = 0V$	I_{GSS}	--	--	± 100	nA
Zero Gate Voltage Drain Current	$V_{DS} = 600V, V_{GS} = 0V$	I_{DSS}	--	--	20	μA
Drain-Source On-State Resistance	$V_{GS} = 10V, I_D = 5A$	$R_{DS(ON)}$	--	0.61	0.75	Ω
Dynamic^b						
Total Gate Charge	$V_{DS} = 300V, I_D = 10A,$ $V_{GS} = 10V$	Q_g	--	45.8	--	nC
Gate-Source Charge		Q_{gs}	--	11.5	--	
Gate-Drain Charge		Q_{gd}	--	16	--	
Input Capacitance	$V_{DS} = 25V, V_{GS} = 0V,$ $f = 1.0MHz$	C_{iss}	--	1738	--	pF
Output Capacitance		C_{oss}	--	195	--	
Reverse Transfer Capacitance		C_{rss}	--	26.3	--	
Switching^b						
Turn-On Delay Time	$V_{DD} = 300V, R_G = 10\Omega,$ $I_D = 10A, V_{GS} = 10V,$	$t_{d(on)}$	--	33.6	--	nS
Turn-On Rise Time		t_r	--	7.4	--	
Turn-Off Delay Time		$t_{d(off)}$	--	68	--	
Turn-Off Fall Time		t_f	--	15.2	--	
Source-Drain Diode^a						
Forward On Voltage	$I_S = 10A, V_{GS} = 0V$	VSD	--	0.8	1.5	V

Notes a: Pulse test: PW $\leq 300\mu S$, duty cycle $\leq 2\%$

Notes b: For DESIGN AID ONLY, not subject to production testing.

Notes c: Switching time is essentially independent of operating temperature.

Gate Charge Test Circuit & Waveform

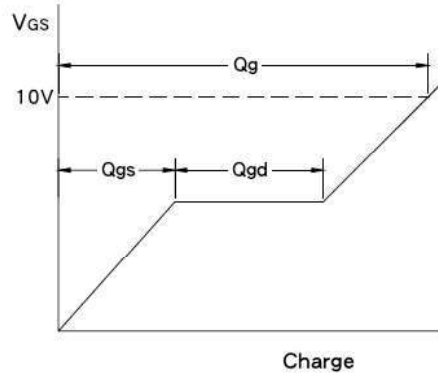
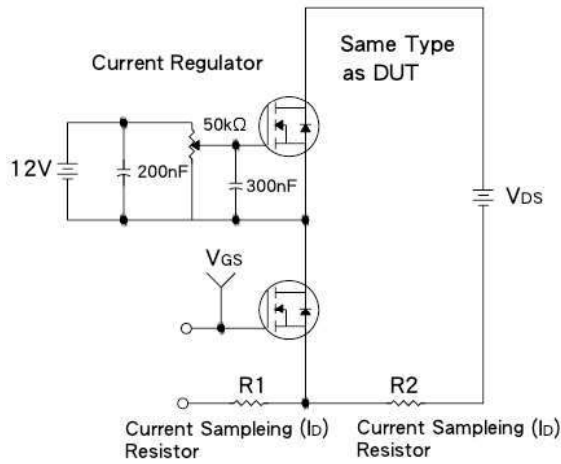

Resistive Switching Test Circuit & Waveform

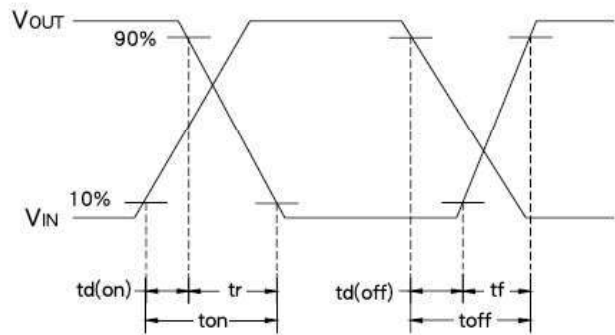
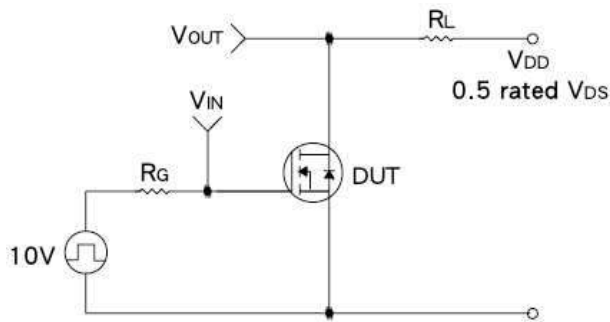

EAS Test Circuit & Waveform

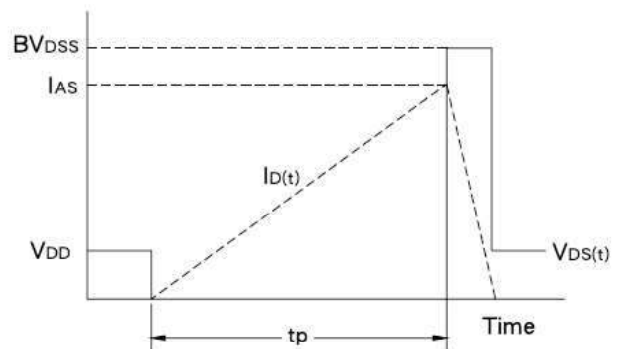
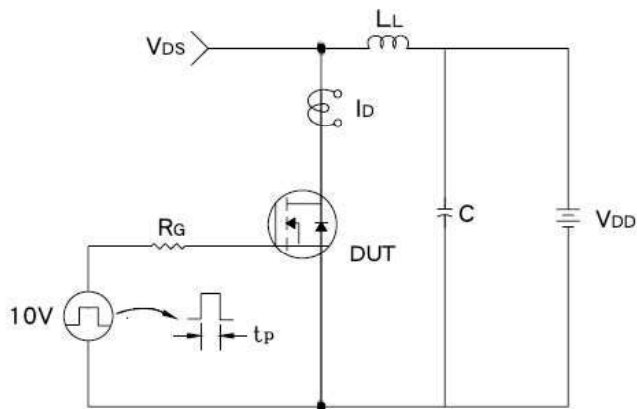

Diode Reverse Recovery Time Test Circuit & Waveform

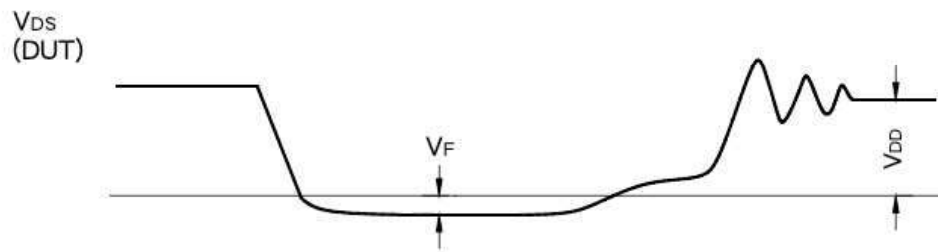
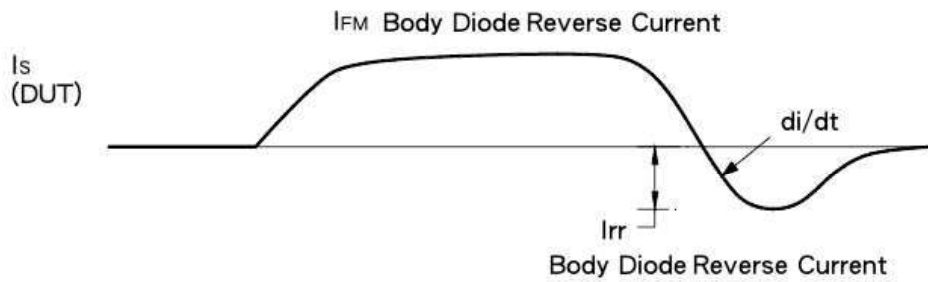
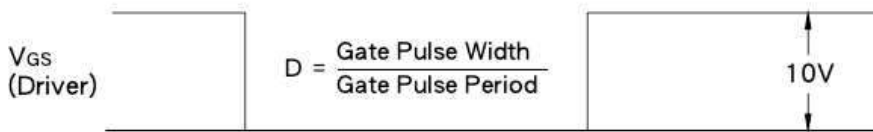
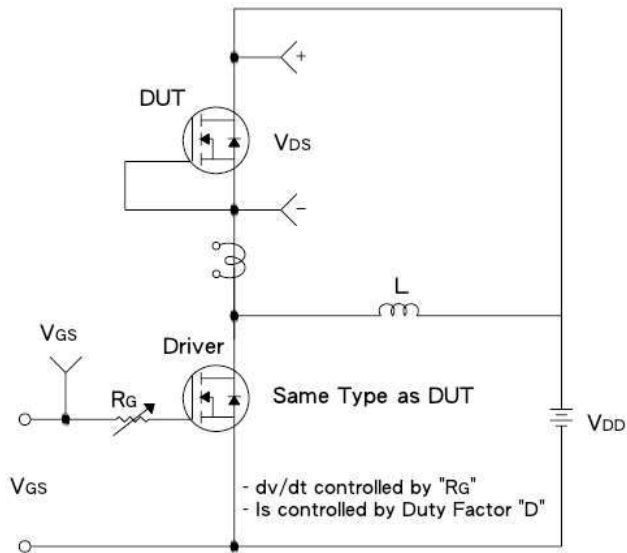

Electrical Characteristics Curve (Ta = 25°C, unless otherwise noted)

Output Characteristics

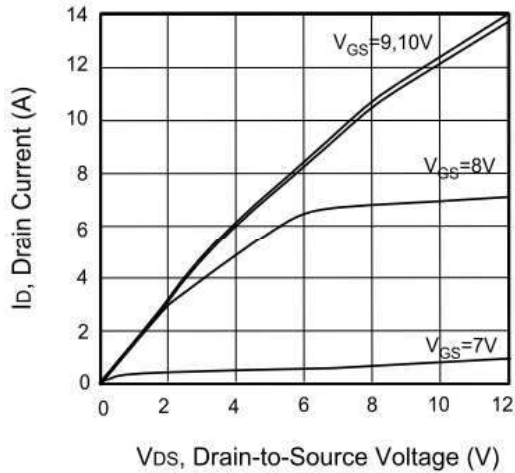

Transfer Characteristics

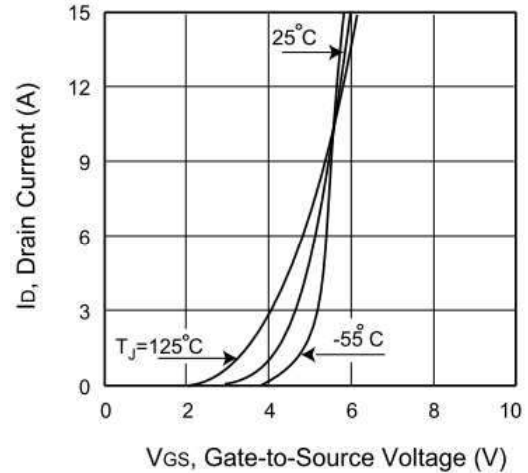

Threshold Voltage

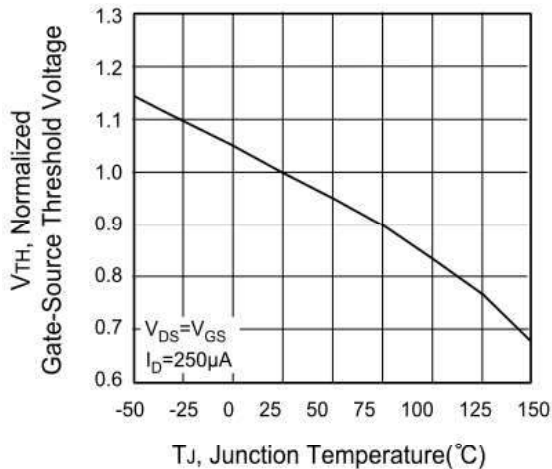

Gate Charge

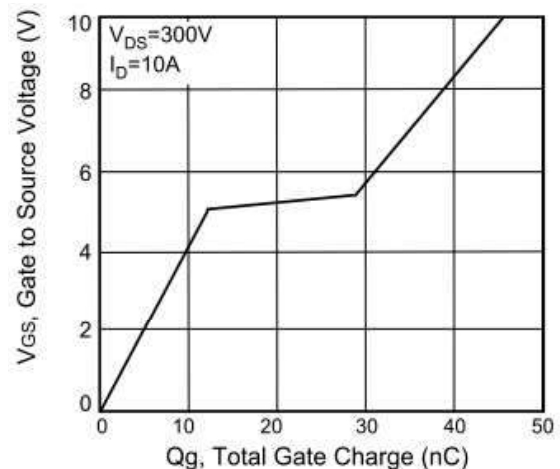

On-Resistance vs. Junction Temperature

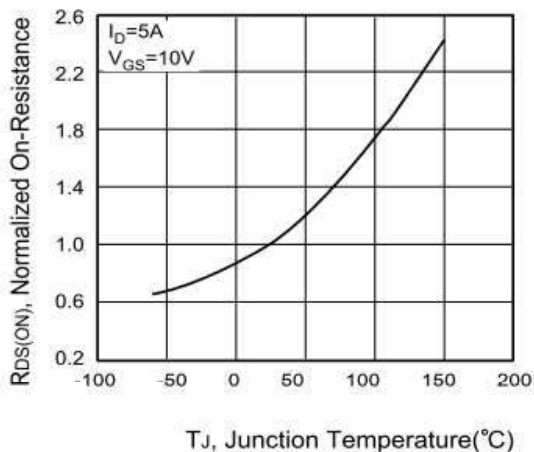

Source-Drain Diode Forward Voltage

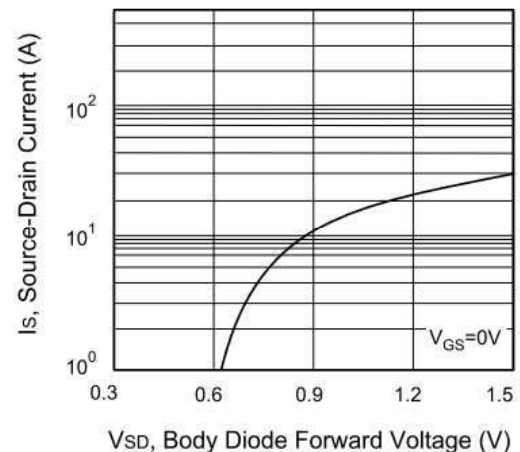

Electrical Characteristics Curve ($T_a = 25^\circ\text{C}$, unless otherwise noted)

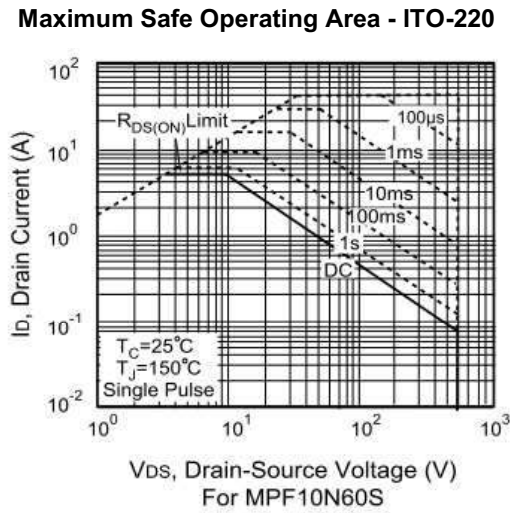
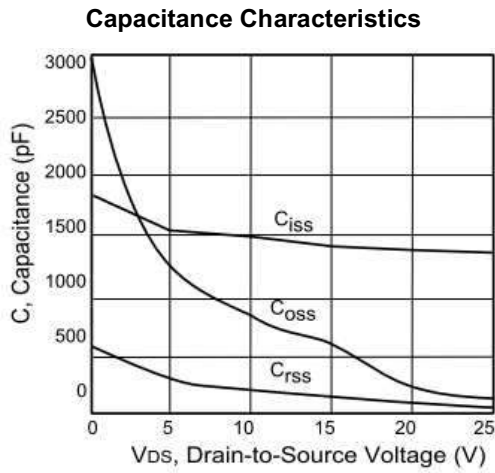

Normalized Thermal Transient Impedance, Junction-to-Ambient

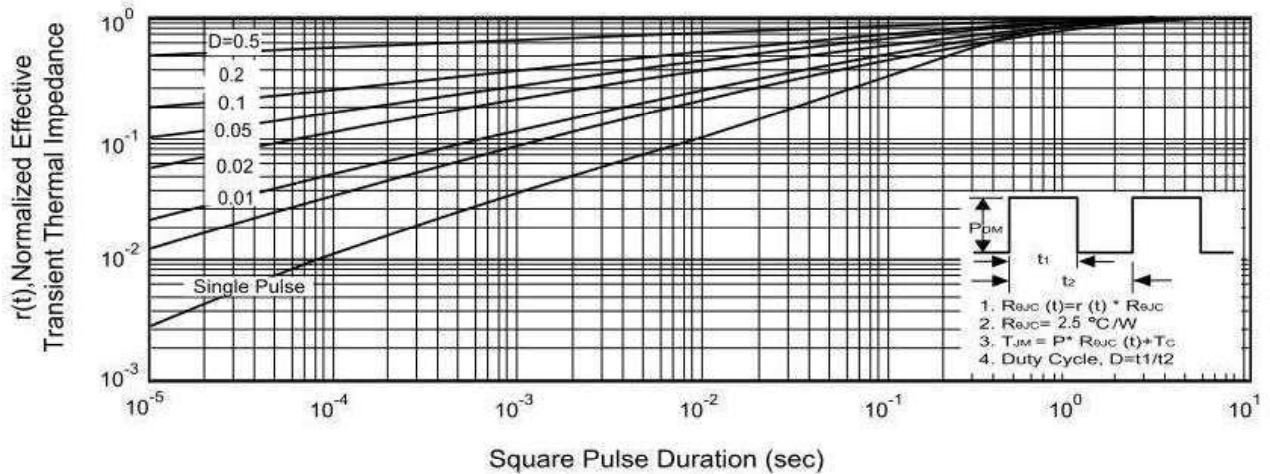

TO-220 Mechanical Drawing

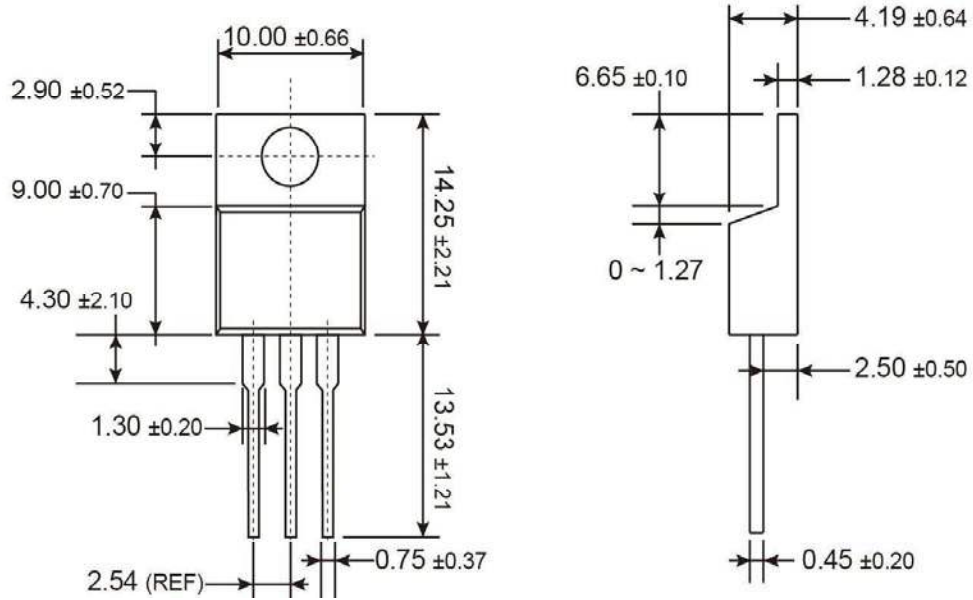

Unit: Millimeters

ITO-220 Mechanical Drawing

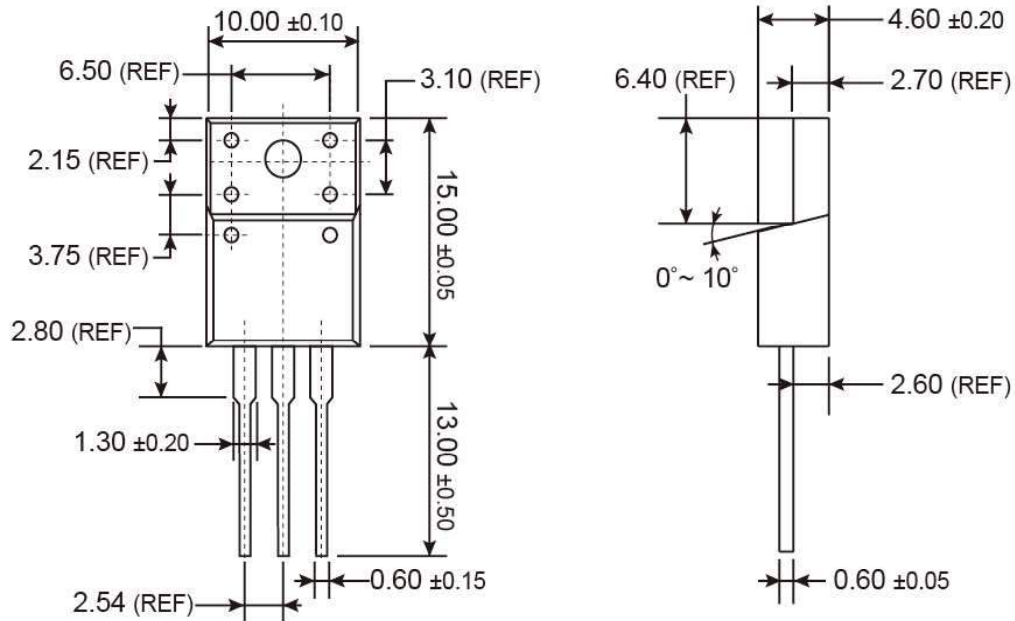

Unit: Millimeters

Notice

Specifications of the products displayed herein are subject to change without notice. TSC or anyone on its behalf, assumes no responsibility or liability for any errors or inaccuracies.

Information contained herein is intended to provide a product description only. No license, express or implied, to any intellectual property rights is granted by this document. Except as provided in TSC's terms and conditions of sale for such products, TSC assumes no liability whatsoever, and disclaims any express or implied warranty, relating to sale and/or use of TSC products including liability or warranties relating to fitness for a particular purpose, merchantability, or infringement of any patent, copyright, or other intellectual property right.

The products shown herein are not designed for use in medical, life-saving, or life-sustaining applications. Customers using or selling these products for use in such applications do so at their own risk and agree to fully indemnify TSC for any damages resulting from such improper use or sale.