

REVISIONS					
P.	LTN.	DESCRIPTION	DATE	DWN.	APVD.
C		REVISED PER ECR-16-005516	25APR2016	DLD	CJS

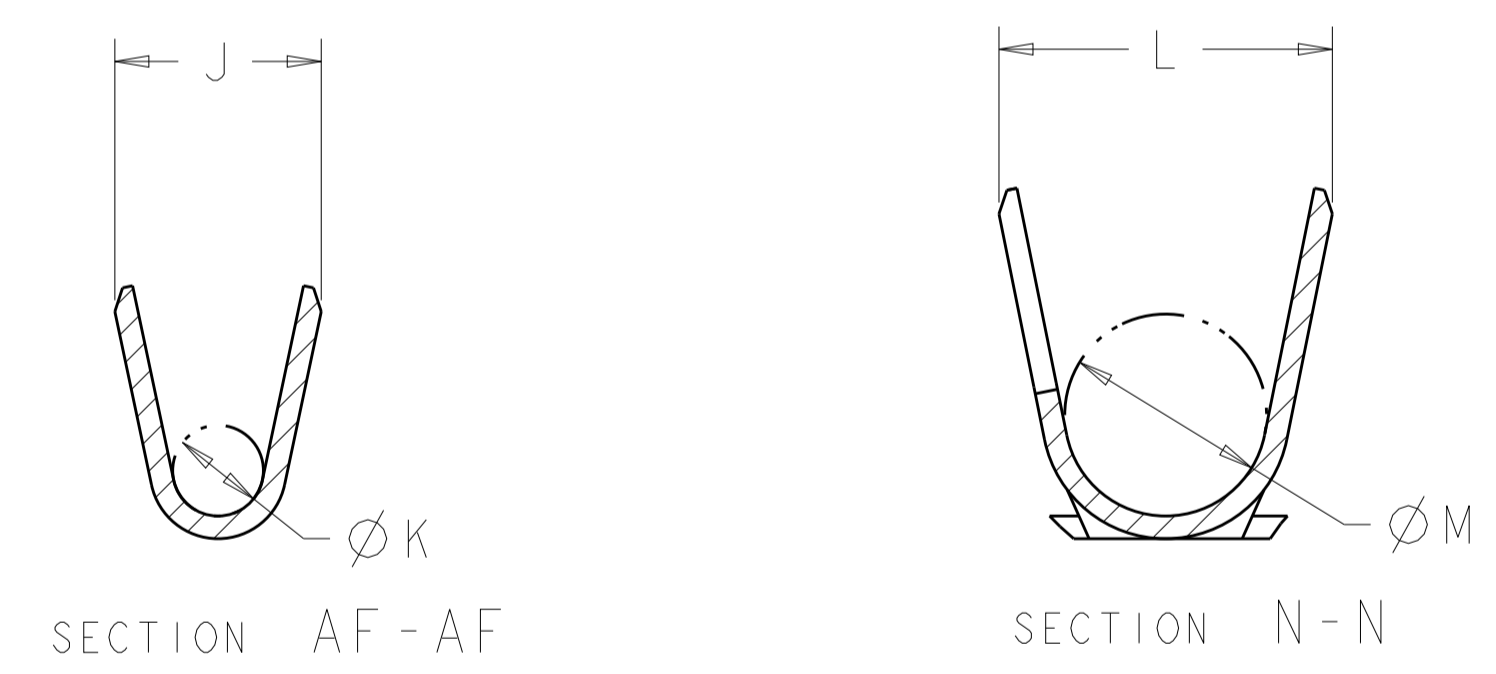
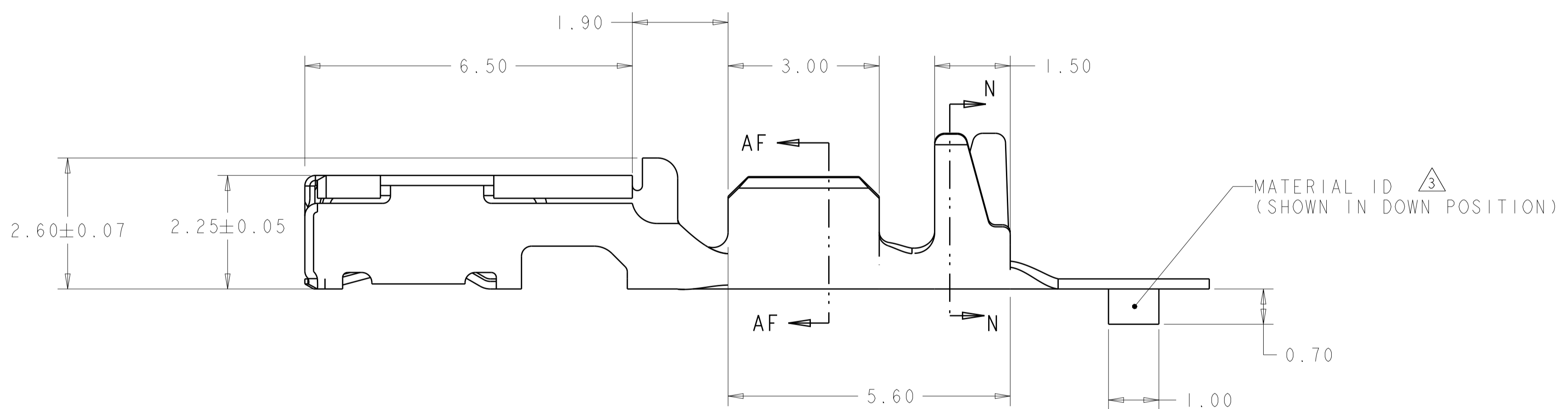
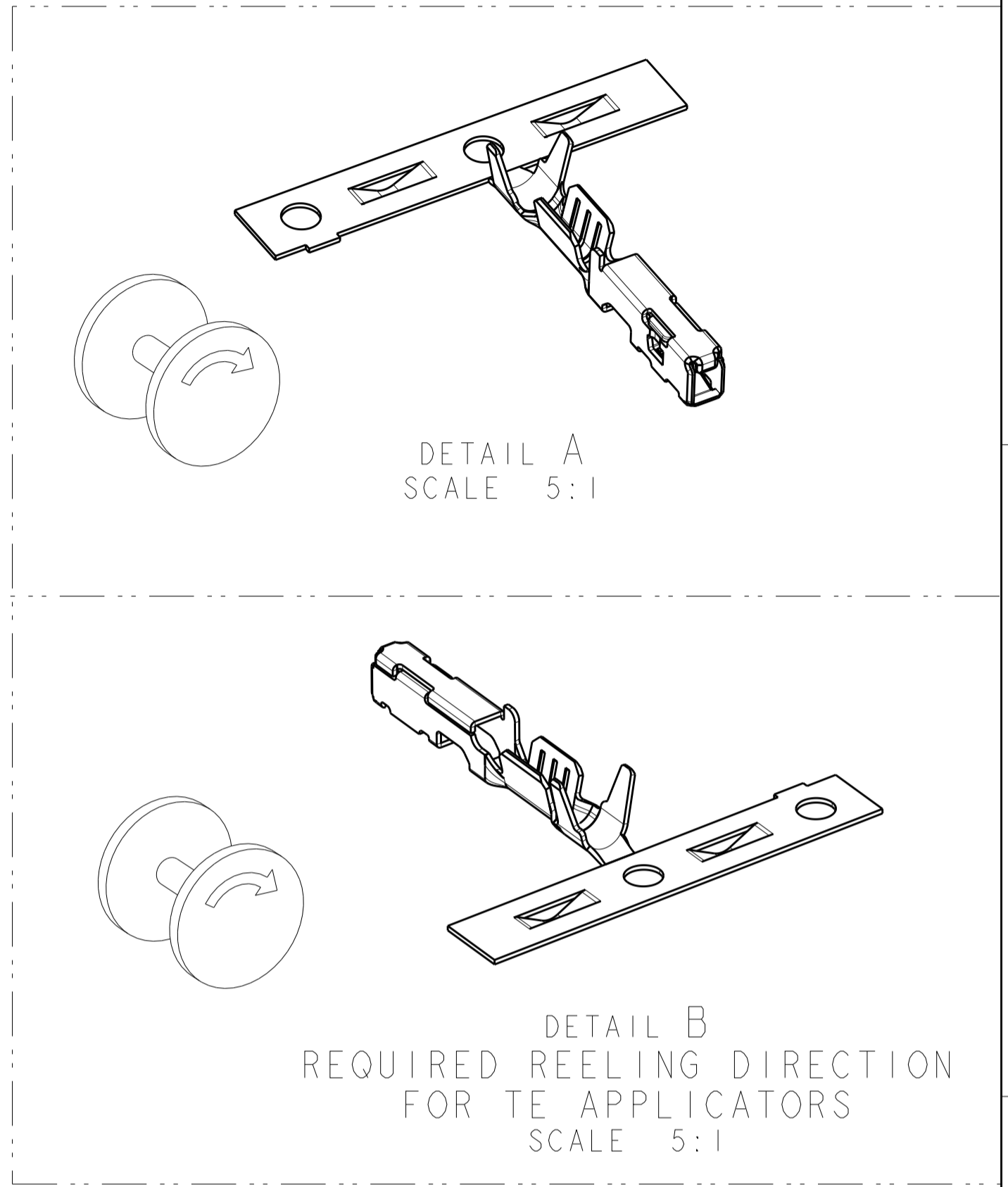
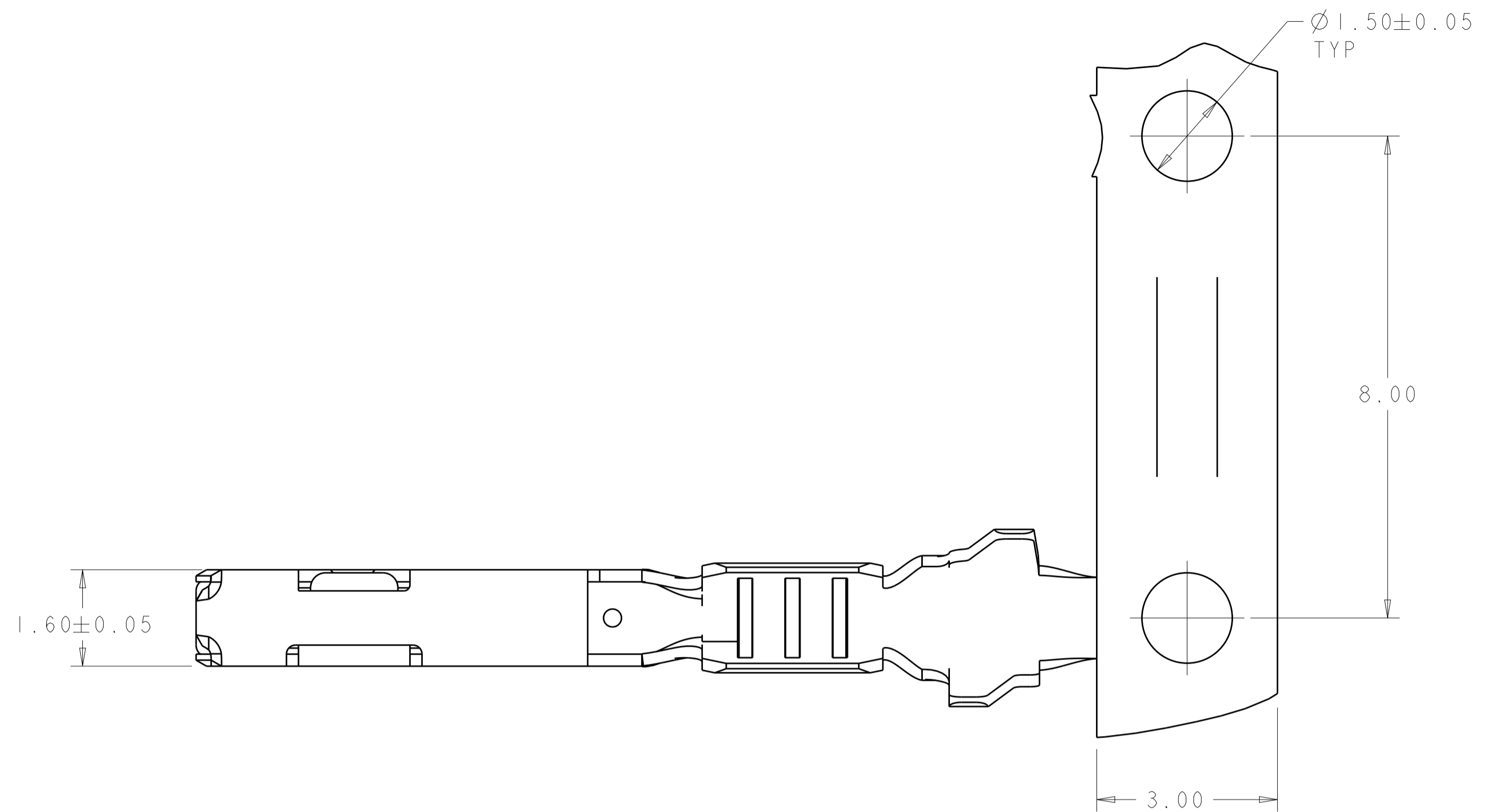

- 1 MATERIAL: COPPER ALLOY
- 2 FINISH: PRE-PLATED WITH 1.00µm MIN BRIGHT TIN
- 3 MATERIAL ID FEATURE IN "DOWN" POSITION.
- 4. THE INTENDED TEMPERATURE RANGE FOR THIS TERMINAL IS -40°C TO +100°C.
- 5. TERMINAL HAS NYE LUBRICANTS NYETACT 568J-50-UV PERFORMANCE LUBE/GREASE APPLIED. THIS IS A WHITISH COLORED LUBE. AMOUNT AND VISIBILITY MAY VARY.

0.13mm <sup>2</sup> = 0.85-1.05	DETAIL B	1.40	2.40	0.80	1.85	2	3	2X 0.13mm <sup>2</sup>	1924955-8
0.35mm <sup>2</sup> = 1.10-1.40								0.35mm <sup>2</sup>	
0.85-1.05	DETAIL B	0.85	1.82	0.65	1.50	2	3	26 [0.13mm <sup>2</sup> ]	1924955-7
0.13mm <sup>2</sup> = 0.85-1.05	DETAIL A	1.40	2.40	0.80	1.85	2	3	2X 0.13mm <sup>2</sup>	1924955-6
0.35mm <sup>2</sup> = 1.10-1.40								0.35mm <sup>2</sup>	
0.85-1.05	DETAIL A	0.85	1.82	0.65	1.50	2	3	26 [0.13mm <sup>2</sup> ]	1924955-5
2.06 MAX	DETAIL B	1.78	2.94	1.00	1.96	2	3	18 [0.75mm <sup>2</sup> ]	1924955-4
1.50-1.85	DETAIL B	1.78	2.94	0.80	1.82	2	3	20-22 [0.5-0.35mm <sup>2</sup> ]	1924955-3
2.06 MAX	DETAIL A	1.78	2.94	1.00	1.96	2	3	18 [0.75mm <sup>2</sup> ]	1924955-2
1.50-1.85	DETAIL A	1.78	2.94	0.80	1.82	2	3	20-22 [0.5-0.35mm <sup>2</sup> ]	1924955-1
INSULATION DIAMETER	REELING	M	L	K	J	FINISH		WIRE SIZE	PART NUMBER

THIS DRAWING IS A CONTROLLED DOCUMENT. DWN: F. KINSEY 17DEC2007  
 CHK: F. KINSEY 17DEC2007  
 APVD: J. MYER 17DEC2007

**STE** TE Connectivity

CONTACT, 0.64mm, FEMALE, GENERATION Y, UNSEALED APPLICATIONS

SIZE: 108-2296  
 APPLICATION SPEC: 114-13183  
 WEIGHT: -  
 CUSTOMER DRAWING

SCALE: 15:1 SHEET 1 OF 1 REV C