

National Semiconductor is now part of  
Texas Instruments.

Search <http://www.ti.com/> for the latest technical  
information and details on our current products and services.

# DS96F172M/DS96F174C/DS96F174M

## EIA-485/EIA-422 Quad Differential Drivers

### General Description

The DS96F172 and the DS96F174 are high speed quad differential line drivers designed to meet EIA-485 Standards. The DS96F172 and the DS96F174 offer improved performance due to the use of L-FAST bipolar technology. The use of LFAST technology allows the DS96F172 and DS96F174 to operate at higher speeds while minimizing power consumption.

The DS96F172 and the DS96F174 have TRI-STATE® outputs and are optimized for balanced multipoint data bus transmission at rates up to 15 Mbps. The drivers have wide positive and negative common mode range for multipoint applications in noisy environments. Positive and negative current-limiting is provided which protects the drivers from line fault conditions over a +12V to -7.0V common mode range. A thermal shutdown feature is also provided. The DS96F172 features an active high and active low Enable, common to all four drivers. The DS96F174 features separate active high Enables for each driver pair.

### Features

- Meets EIA-485 and EIA-422 standards
- Monotonic differential output switching
- TRI-STATE outputs
- Designed for multipoint bus transmission
- Common mode output voltage range: -7.0V to +12V
- Operates from single +5.0V supply
- Reduced power consumption
- Thermal shutdown protection
- DS96F172 and DS96F174 are lead and function compatible with the SN75172/174 or the AM26LS31/MC3487
- Military temperature range available
- Qualified for MIL-STD-883C
- Standard military drawings available (SMD)
- Available in DIP (J), LCC (E), and Flatpak (W) packages

### Logic Diagrams

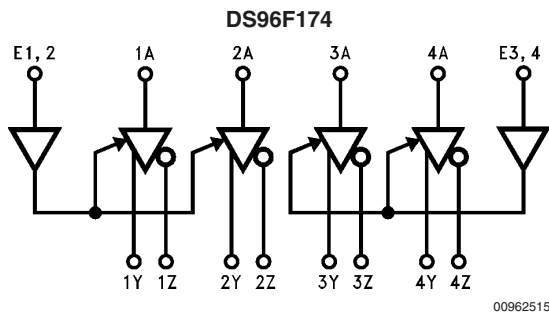
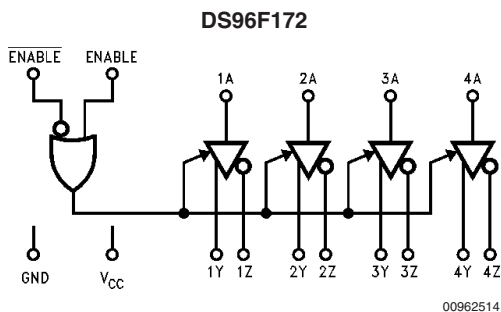

### Function Tables (Each Driver)

DS96F172

Input	Enable		Outputs	
A	E	$\bar{E}$	Y	Z
H	H	X	H	L
L	H	X	L	H
H	X	L	H	L
L	X	L	L	H
X	L	H	Z	Z

DS96F174

Input	Enable	Outputs	
A	E	Y	Z
H	H	H	L
L	H	L	H
X	L	Z	Z

H = High Level  
 L = Low Level  
 X = Don't Care  
 Z = High Impedance (Off)

TRI-STATE® is a registered trademark of National Semiconductor Corporation.

**Absolute Maximum Ratings****COMMERCIAL** (Note 2)

Specifications for the 883 version of this product are listed separately on the following pages.

Storage Temperature Range ( $T_{STG}$ )	-65°C to +175°C
Lead Temperature (Soldering, 60 sec.)	300°C
Maximum Package Power Dissipation (Note 1) at 25°C	
Ceramic DIP (J)	1500 mW
Supply Voltage	7.0V
Enable Input Voltage	5.5V

**Recommended Operating Conditions**

	Min	Typ	Max	Units
Supply Voltage ( $V_{CC}$ )				
DS96F174C	4.75	5.0	5.25	V
Common Mode	-7.0		+12.0	V
Output Voltage ( $V_{OC}$ )				
Output Current HIGH ( $I_{OH}$ )			-60	mA
Output Current LOW ( $I_{OL}$ )			60	mA
Operating Temperature ( $T_A$ )				
DS96F174C	0		+70	°C

Note 1: Derate "J" package 10 mW/°C above 25°C.

**Electrical Characteristics** (Notes 3, 4)

Over recommended supply voltage and operating temperature range, unless otherwise specified

Symbol	Parameter	Conditions	Min	Typ (Note 2)	Max	Units
$V_{IH}$	Input Voltage HIGH		2.0			V
$V_{IL}$	Input Voltage LOW	$T_A = 0^\circ\text{C to } +70^\circ\text{C}$			0.8	V
		$T_A = -55^\circ\text{C to } +125^\circ\text{C}$			0.7	
$V_{OH}$	Output Voltage HIGH	$I_{OH} = -33\text{ mA}$ $T_A = 0^\circ\text{C to } +70^\circ\text{C}$	3.0			V
$V_{OL}$	Output Voltage LOW	$I_{OL} = 33\text{ mA}$ $T_A = 0^\circ\text{C to } +70^\circ\text{C}$			2.0	V
$V_{IC}$	Input Clamp Voltage	$I_I = -18\text{ mA}$			-1.5	V
$ V_{OD1} $	Differential Output Voltage	$I_O = 0\text{ mA}$			6.0	V
$ V_{OD2} $	Differential Output Voltage	$R_L = 54\Omega$ , Figure 1	$T_A = -55^\circ\text{C}$	1.2	2.0	V
				1.5		
		$R_L = 100\Omega$ , Figure 1		2.0	2.3	
$V_{OD}$	Differential Output Voltage	Figure 2 $T_A = 0^\circ\text{C to } +70^\circ\text{C}$	1.0			V
$\Delta V_{OD} $	Change in Magnitude of Differential Output Voltage (Note 5)	$R_L = 54\Omega$ or $100\Omega$ , Figure 1	$-40^\circ\text{C to } +125^\circ\text{C}$		$\pm 0.2$	V
			$-55^\circ\text{C to } +125^\circ\text{C}$		$\pm 0.4$	
$V_{OC}$	Common Mode Output Voltage (Note 6)	$R_L = 54\Omega$ or $100\Omega$ , Figure 1			3.0	V
$\Delta V_{OC} $	Change in Magnitude of Common Mode Output Voltage (Note 5)	$R_L = 54\Omega$ or $100\Omega$ , Figure 1			$\pm 0.2$	V
$I_O$	Output Current with Power Off	$V_{CC} = 0\text{V}$ , $V_O = -7.0\text{V to } +12\text{V}$			$\pm 50$	$\mu\text{A}$
$I_{OZ}$	High Impedance State Output Current	$V_O = -7.0\text{V to } +12\text{V}$		$\pm 20$	$\pm 50$	$\mu\text{A}$
$I_{IH}$	Input Current HIGH	$V_I = 2.4\text{V}$			20	$\mu\text{A}$
$I_{IL}$	Input Current LOW	$V_I = 0.4\text{V}$			-50	$\mu\text{A}$
$I_{OS}$	Short Circuit Output Current (Note 7)	$V_O = -7.0\text{V}$			-250	mA
		$V_O = 0\text{V}$			-150	
		$V_O = V_{CC}$			150	
		$V_O = +12\text{V}$			250	
$I_{CC}$	Supply Current (All Drivers)	No Load	Outputs Enabled		50	mA
			Outputs Disabled		30	

**COMMERCIAL****Switching Characteristics** $V_{CC} = 5.0V$ ,  $T_A = 25^\circ C$ 

Symbol	Parameter	Conditions	Min	Typ	Max	Units
$t_{DD}$	Differential Output Delay Time	$R_L = 60\Omega$ , <i>Figure 3</i>		15	20	ns
$t_{TD}$	Differential Output Transition Time			15	22	ns
$t_{PLH}$	Propagation Delay Time, Low-to-High Level Output	$R_L = 27\Omega$ , <i>Figure 4</i>		12	16	ns
$t_{PHL}$	Propagation Delay Time, High-to-Low Level Output			12	16	ns
$t_{ZH}$	Output Enable Time to High Level	$R_L = 110\Omega$ , <i>Figure 4</i>		25	32	ns
$t_{ZL}$	Output Enable Time to Low Level	$R_L = 110\Omega$ , <i>Figure 6</i>		25	32	ns
$t_{HZ}$	Output Disable Time from High Level	$R_L = 110\Omega$ , <i>Figure 5</i>		25	30	ns
$t_{LZ}$	Output Disable Time from Low Level	$R_L = 110\Omega$ , <i>Figure 6</i>		20	25	ns
$t_{LZL}$	Output Disable Time from Low Level with Load Resistor to GND (Note 8)	<i>Figure 6</i>		300		ns
$t_{SKEW}$	Driver Output to Output	$R_L = 60\Omega$		1.0	4.0	ns

**Note 2:** "Absolute Maximum Ratings" are those values beyond which the safety of the device cannot be guaranteed. They are not meant to imply that the devices should be operated at these limits. The tables of "Electrical Characteristics" provide conditions for actual device operation.

**Note 3:** Unless otherwise specified min/max limits apply across the  $0^\circ C$  to  $+70^\circ C$  range for the DS96F174C. All typicals are given for  $V_{CC} = 5V$  and  $T_A = 25^\circ C$ .

**Note 4:** All currents into the device pins are positive; all currents out of the device pins are negative. All voltages are reference to ground unless otherwise specified.

**Note 5:**  $\Delta I_{V_{OD}}$  and  $\Delta I_{V_{OC}}$  are the changes in magnitude of  $V_{OD}$  and  $V_{OC}$  respectively, that occur when the input is changed from a high level to a low level.

**Note 6:** In EIA-422A and EIA-485 standards,  $V_{OC}$ , which is the average of the two output voltages with respect to ground, is called output offset voltage,  $V_{OS}$ .

**Note 7:** Only one output at a time should be shorted.

**Note 8:** For more information see Application Bulletin, contact Product Marketing.

**Order Number: DS96F174CJ**  
**DS96F174CN**

**NS Package Number J16A or N16E**

**MIL-STD-883C****Absolute Maximum Ratings** (Note 2)

For complete Military Specifications, refer to the appropriate SMD or MDS.

Storage Temperature Range ( $T_{STG}$ )	-65°C to +175°C
Lead Temperature (Soldering, 60 sec.)	300°C
Maximum Package Power Dissipation (Note 9) at 25°C	
Ceramic LCC (E)	2000 mW
Ceramic DIP (J)	1800 mW
Ceramic Flatpak (W)	1000 mW
Supply Voltage	7.0V
Enable Input Voltage	5.5V

**Recommended Operating Conditions**

	Min	Typ	Max	Units
Supply Voltage ( $V_{CC}$ )				
DS96F172M/DS96F174M	4.50	5.0	5.50	V
Common Mode	-7.0		+12.0	V
Output Voltage ( $V_{OC}$ )				
Output Current HIGH ( $I_{OH}$ )			-60	mA
Output Current LOW ( $I_{OL}$ )			60	mA
Operating Temperature ( $T_A$ )				
DS96F172M/DS96F174M	-55		+125	

**Note 9:** Above  $T_A = 25^\circ\text{C}$ , derate "E" package 13.4, "J" package 12.5, "W" package 7.1 mW/°C

**Electrical Characteristics** (Notes 3, 4)

Over recommended supply voltage and operating temperature range unless otherwise specified

Symbol	Parameter	Conditions	Min	Max	Units
$V_{IH}$	Input Voltage HIGH		2.0		V
$V_{IL}$	Input Voltage LOW	$T_A = 25^\circ\text{C}$		0.8	V
		$T_A = -55^\circ\text{C}$ , or $+125^\circ\text{C}$		0.7	V
$V_{IC}$	Input Clamp Voltage	$I_I = -18\text{ mA}$		-1.5	V
$IV_{OD1}$	Differential Output Voltage	$I_O = 0\text{ mA}$		6.0	V
$IV_{OD2}$	Differential Output Voltage	$R_L = 54\Omega$ , $V_{CC} = 4.5\text{V}$ <i>Figure 1</i>	$T_A = -55^\circ\text{C}$ 1.2		V
			$T_A = 25^\circ\text{C}$ , or $+125^\circ\text{C}$ 1.5		
		$R_L = 100\Omega$ , $V_{CC} = 4.5\text{V}$ , <i>Figure 1</i>	2.0		
$\Delta IV_{OD}$	Change in Magnitude of Differential Output Voltage (Note 5)	$R_L = 54\Omega$ or $100\Omega$ , $V_{CC} = 4.5\text{V}$ , <i>Figure 1</i>	$T_A = 25^\circ\text{C}$ , or $+125^\circ\text{C}$	$\pm 0.2$	V
			$T_A = -55^\circ\text{C}$	$\pm 0.4$	V
$V_{OC}$	Common Mode Output Voltage (Note 6)	$R_L = 54\Omega$ or $100\Omega$ , <i>Figure 1</i>		3.0	V
$\Delta V_{OC}$	Change in Magnitude of Common Mode Output Voltage (Note 5)	$R_L = 54\Omega$ or $100\Omega$ , $V_{CC} = 4.5\text{V}$ , <i>Figure 1</i>		$\pm 0.2$	V
$I_O$	Output Current with Power Off	$V_{CC} = 0\text{V}$ , $V_O = -7.0\text{V}$ to $+12\text{V}$		$\pm 50$	$\mu\text{A}$
$I_{OZ}$	High Impedance State Output Current	$V_O = -7.0\text{V}$ to $+12\text{V}$		$\pm 50$	$\mu\text{A}$
$I_{IH}$	Input Current HIGH	$V_I = 2.4\text{V}$		20	$\mu\text{A}$
$I_{IL}$	Input Current LOW	$V_I = 0.4\text{V}$		-50	$\mu\text{A}$
$I_{OS}$	Short Circuit Output Current (Note 7)	$V_O = -7.0\text{V}$		-250	mA
		$V_O = 0\text{V}$		-150	
		$V_O = V_{CC}$		150	
		$V_O = +12\text{V}$		250	
$I_{CC}$	Supply Current (All Drivers)	No Load	Outputs Enabled	50	mA
$I_{CCX}$			Outputs Disabled	30	

# MIL-STD-883C

## Switching Characteristics

$V_{CC} = 5.0V$

Symbol	Parameter	Conditions	$T_A = 25^\circ C$		$T_A = 55^\circ C$	$T_A = 125^\circ C$	Units
			Typ	Max	Max	Max	
$t_{DD}$	Differential Output Delay Time	$R_L = 60\Omega, C_L = 15 pF,$	15	22	30	30	ns
$t_{TD}$	Differential Output Transition Time	Figure 3	15	22	40	40	ns
$t_{PLH}$	Propagation Delay Time, Low-to-High Level Output	$R_L = 27\Omega, C_L = 15 pF,$ Figure 4	12	16	25	25	ns
$t_{PHL}$	Propagation Delay Time, High-to-Low Level Output		12	16	25	25	ns
$t_{ZH}$	Output Enable Time to High Level	$R_L = 110\Omega,$ Figure 5	25	32	40	40	ns
$t_{ZL}$	Output Enable Time to Low Level	$R_L = 110\Omega,$ Figure 6	25	35	100	100	ns
$t_{HZ}$	Output Disable Time from High Level	$R_L = 110\Omega,$ Figure 5, Note 13	25	30	80	80	ns
$t_{LZ}$	Output Disable Time from Low Level	$R_L = 110\Omega,$ Figure 6	20	25	40	40	ns
$t_{LZL}$	Output Disable Time from Low Level with Load Resistor to GND (Note 12)	Figure 6	300				ns
$t_{SKEW}$	Driver Output to Output	$R_L = 60\Omega$	1.0	4.0	10	10	ns

**SMD Numbers:** DS96F172MJ/883 5962-9076501MEA  
 DS96F174MJ/883 5962-9076502MEA

DS96F172ME/883 5962-9076501M2A  
 DS96F174MW/883 5962-9076502MFA  
 DS96F174ME/883 5962-9076502M2A

DS96F172ME/883, DS96F174ME/883  
 NS Package Number E20A  
 DS96F172MW-MIL, DS96F174MW/883  
 NS Package Number W16A

For Complete Military Product Specifications, refer to the appropriate SMD or MDS.

Order Number: DS96F172MJ/883, DS96F174MJ/883  
 NS Package Number J16A

### Parameter Measurement Information

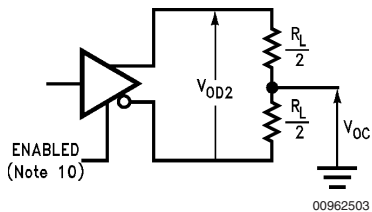

FIGURE 1. Differential and Common Mode Output Voltage

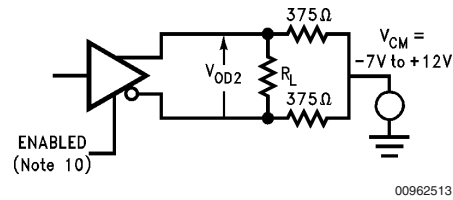

FIGURE 2. Differential Output Voltage with Varying Common Mode Voltage

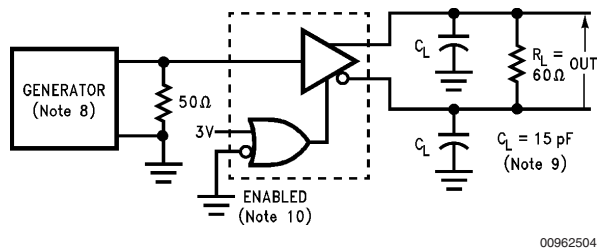
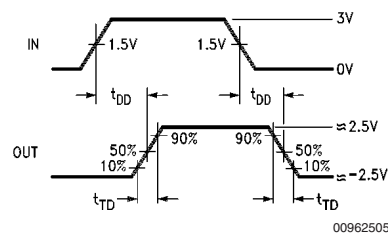
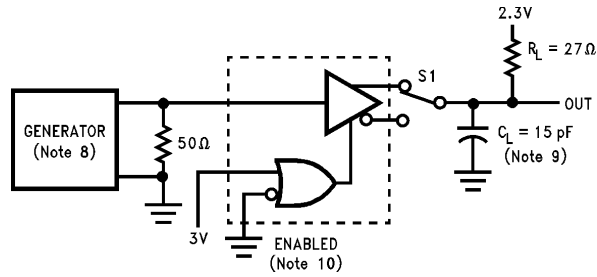

FIGURE 3. Differential Output Delay and Transition Times



Parameter Measurement Information (Continued)



00962506

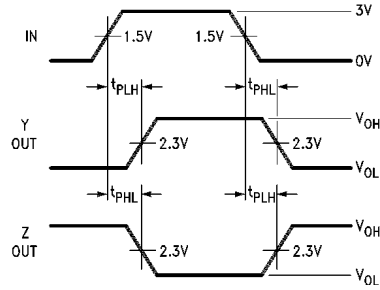

00962507

FIGURE 4. Propagation Delay Times

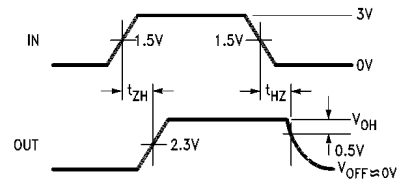
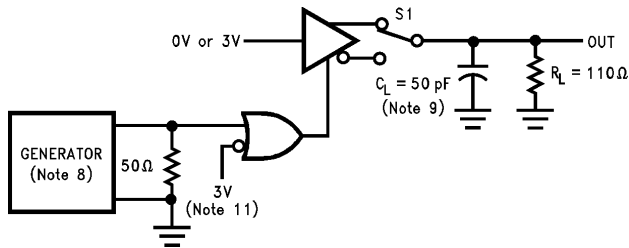

00962509

00962508

FIGURE 5.  $t_{ZH}$  and  $t_{HZ}$

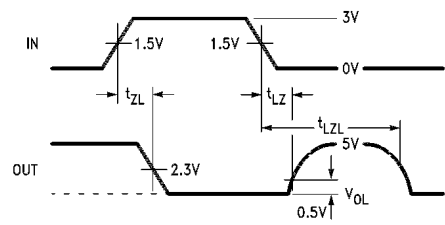
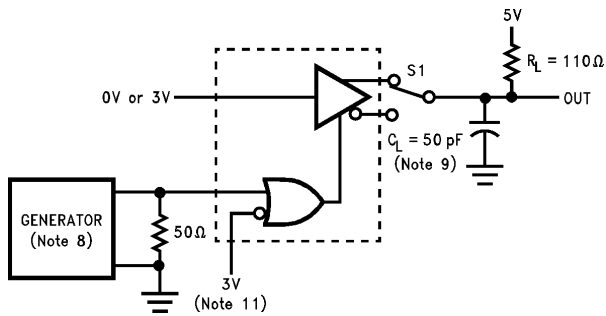

00962511

00962510

FIGURE 6.  $t_{ZL}$ ,  $t_{LZ}$ ,  $t_{LZL}$

**Note 10:** The input pulse is supplied by a generator having the following characteristics:  $f = 1.0$  MHz, duty cycle = 50%,  $t_r \leq 5.0$  ns,  $t_f \leq 5.0$  ns,  $Z_O = 50\Omega$ .

**Note 11:**  $C_L$  includes probe and jig capacitance.

**Note 12:** DS96F172 with active high and active low Enables is shown. DS96F174 has active high Enable only.

**Note 13:** To test the active low Enable  $\bar{E}$  of DS96F172 ground E and apply an inverted waveform to  $\bar{E}$ . DS96F174 has active high Enable only.

**Note 14:** For more information see Application Bulletin, Contact Product Marketing.

**Note 15:** Not tested for DS96F172MW-MIL device.

## Typical Application

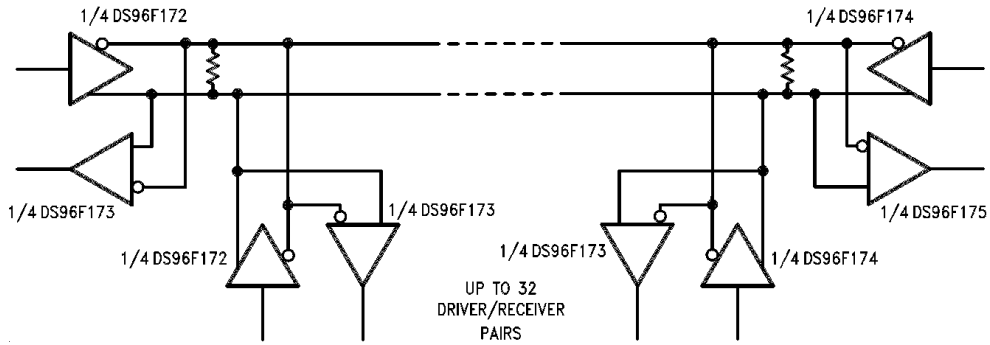

00962512

The line length should be terminated at both ends in its characteristic impedance.  
Stub lengths off the main line should be kept as short as possible.

## Connection Diagrams

16-Lead Ceramic Dual-In-Line Package  
NS Package Number J16A

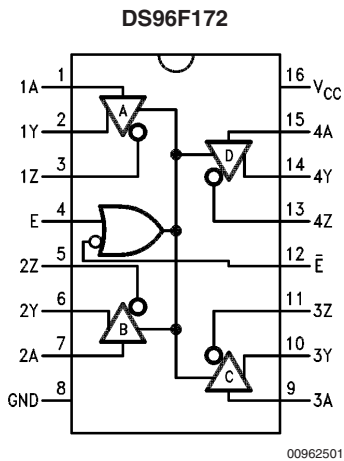

Top View

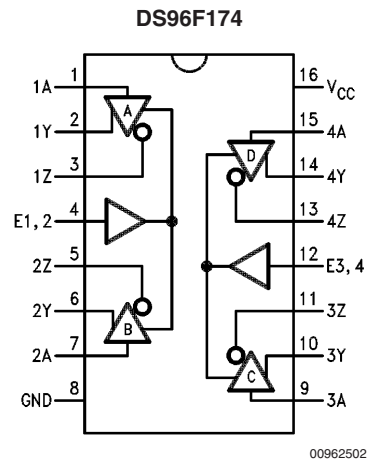

Top View

20-Lead Ceramic Leadless Chip Carrier  
NS Package Number E20A

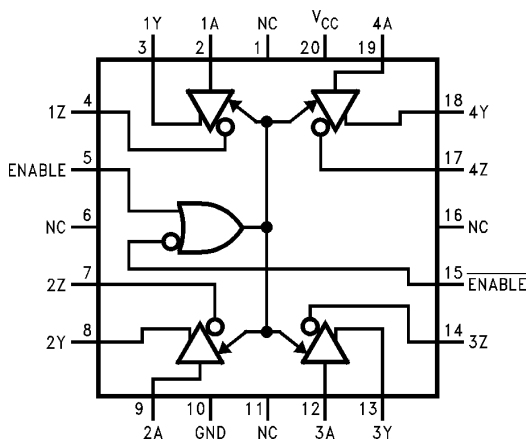

Top View

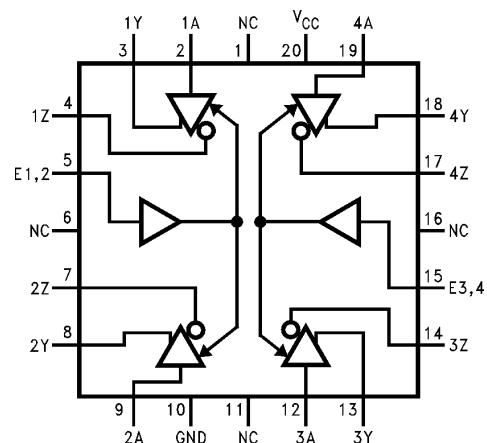

Top View

NC = No connection



## Connection Diagrams (Continued)

16-Lead Ceramic Flatpak  
NS Package Number W16A

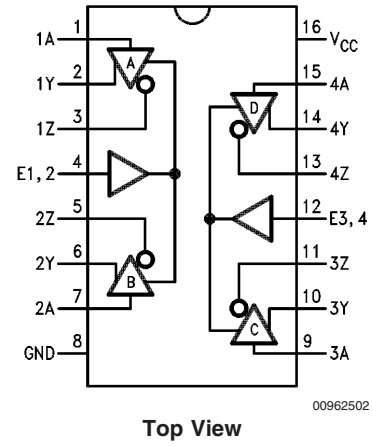
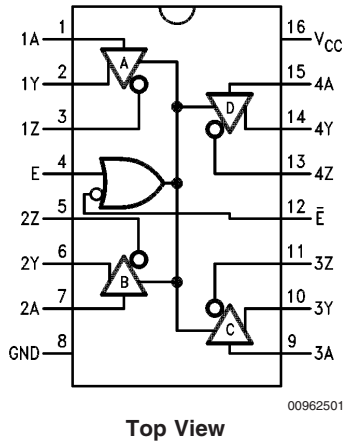

Order Numbers are located at the end of the respective Electrical Tables.

**Physical Dimensions** inches (millimeters)

unless otherwise noted

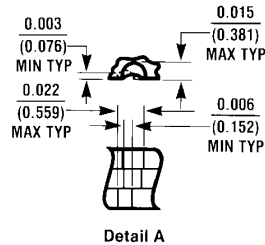
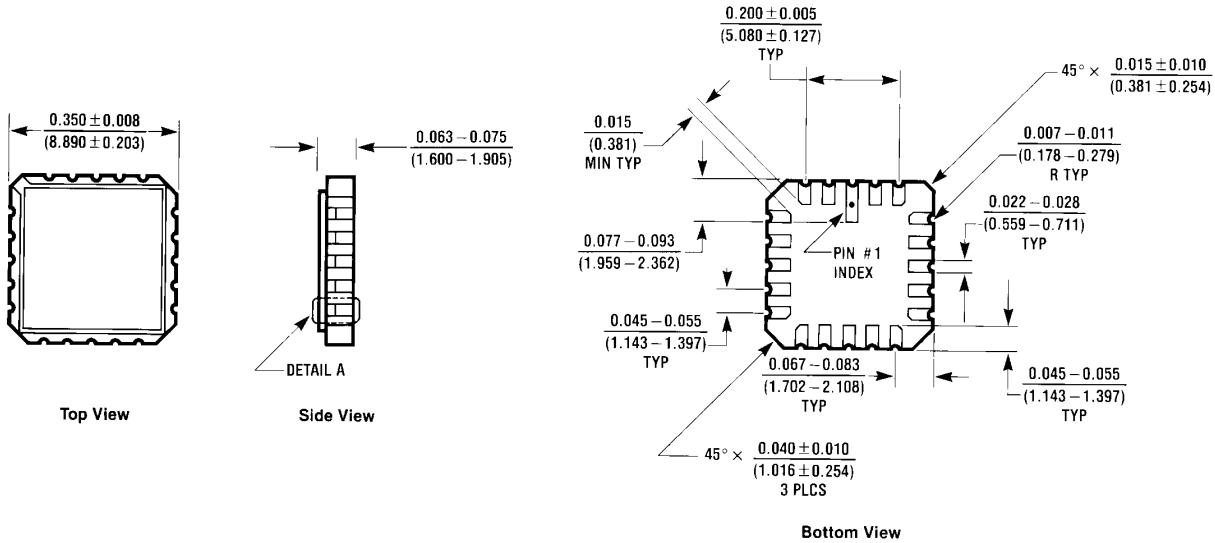

E20A (REV D)

**20-Lead Ceramic Leadless Chip Carrier (E)**  
**Order Number DS96F172ME/883, DS96F174ME/883**  
**NS Package Number E20A**

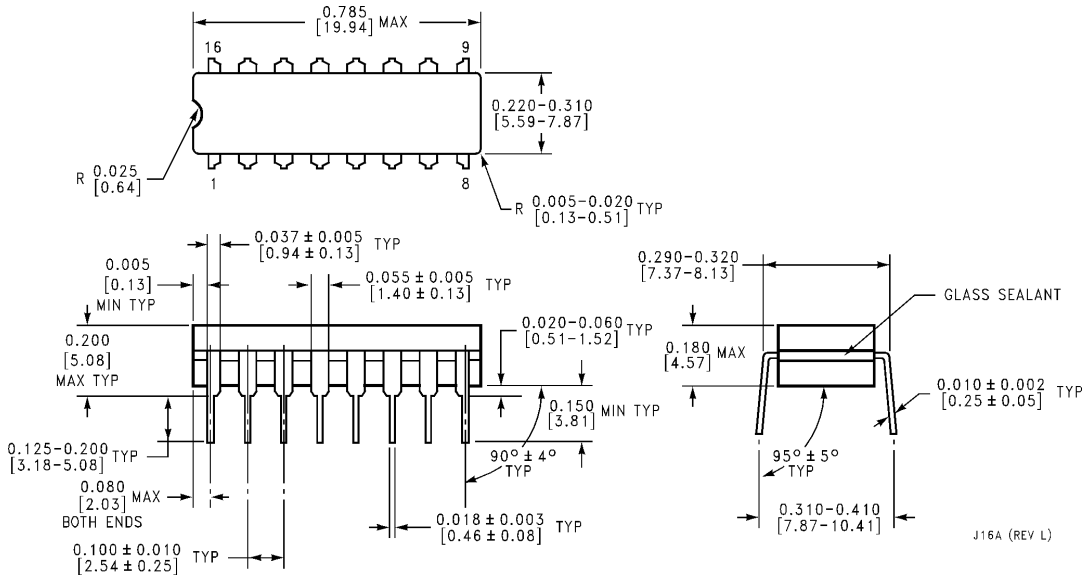

J16A (REV L)

**16-Lead Ceramic Dual-In-Line Package (J)**  
**Order Number DS96F172MJ/883,**  
**DS96F174CJ, DS96F174MJ/883**  
**NS Package Number J16A**

**Physical Dimensions** inches (millimeters) unless otherwise noted (Continued)

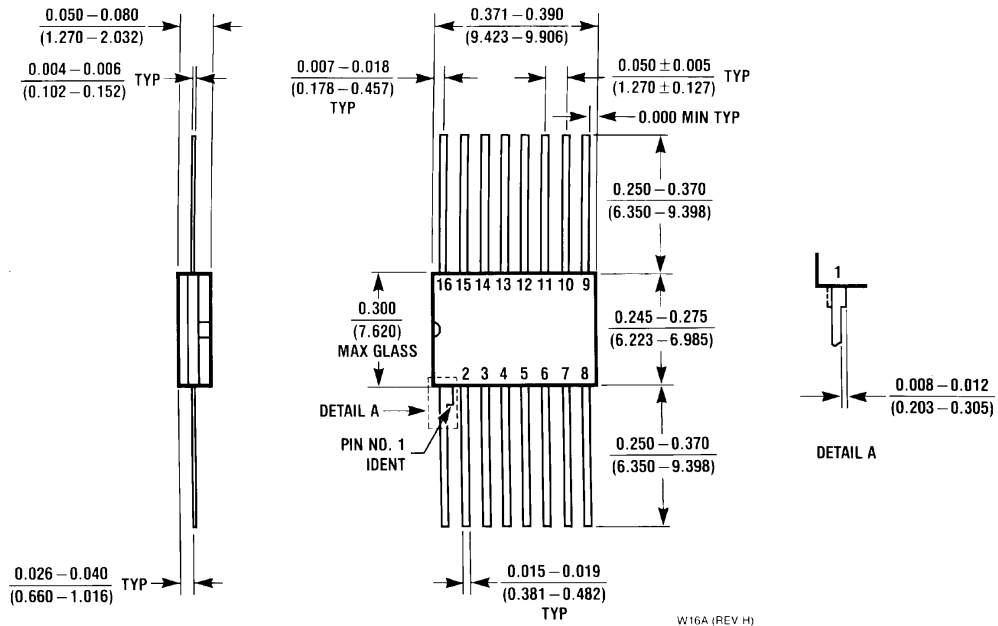

**16-Lead Ceramic Flatpack (W)**  
**Order Number DS96F172MW/883, DS96F174MW/883**  
**NS Package Number W16A**

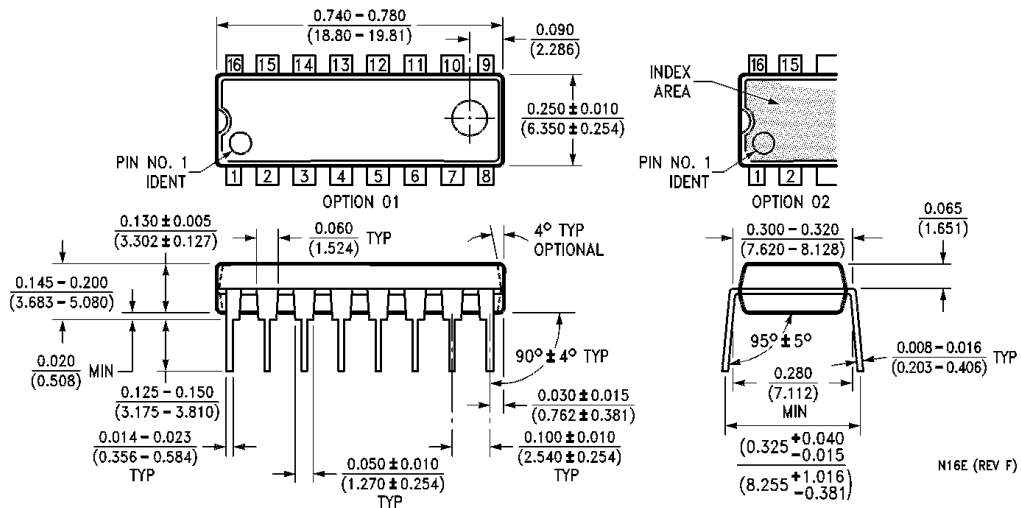

**Molded Dual-In-Line Package (N)**  
**Order Number DS96F174CN**  
**NS Package Number N16E**

## Notes

National does not assume any responsibility for use of any circuitry described, no circuit patent licenses are implied and National reserves the right at any time without notice to change said circuitry and specifications.

For the most current product information visit us at [www.national.com](http://www.national.com).

### LIFE SUPPORT POLICY

NATIONAL'S PRODUCTS ARE NOT AUTHORIZED FOR USE AS CRITICAL COMPONENTS IN LIFE SUPPORT DEVICES OR SYSTEMS WITHOUT THE EXPRESS WRITTEN APPROVAL OF THE PRESIDENT AND GENERAL COUNSEL OF NATIONAL SEMICONDUCTOR CORPORATION. As used herein:

- |  |   |
|--|---|
| <p>1. Life support devices or systems are devices or systems which, (a) are intended for surgical implant into the body, or (b) support or sustain life, and whose failure to perform when properly used in accordance with instructions for use provided in the labeling, can be reasonably expected to result in a significant injury to the user.</p> | <p>2. A critical component is any component of a life support device or system whose failure to perform can be reasonably expected to cause the failure of the life support device or system, or to affect its safety or effectiveness.</p> |
|--|---|

### BANNED SUBSTANCE COMPLIANCE

National Semiconductor certifies that the products and packing materials meet the provisions of the Customer Products Stewardship Specification (CSP-9-111C2) and the Banned Substances and Materials of Interest Specification (CSP-9-111S2) and contain no "Banned Substances" as defined in CSP-9-111S2.



**National Semiconductor**  
**Americas Customer**  
**Support Center**  
 Email: [new.feedback@nsc.com](mailto:new.feedback@nsc.com)  
 Tel: 1-800-272-9959

**National Semiconductor**  
**Europe Customer Support Center**  
 Fax: +49 (0) 180-530 85 86  
 Email: [europe.support@nsc.com](mailto:europe.support@nsc.com)  
 Deutsch Tel: +49 (0) 69 9508 6208  
 English Tel: +44 (0) 870 24 0 2171  
 Français Tel: +33 (0) 1 41 91 8790

**National Semiconductor**  
**Asia Pacific Customer**  
**Support Center**  
 Email: [ap.support@nsc.com](mailto:ap.support@nsc.com)

**National Semiconductor**  
**Japan Customer Support Center**  
 Fax: 81-3-5639-7507  
 Email: [jpn.feedback@nsc.com](mailto:jpn.feedback@nsc.com)  
 Tel: 81-3-5639-7560