

# ON Semiconductor

## Is Now

# onsemi™

To learn more about onsemi™, please visit our website at  
[www.onsemi.com](http://www.onsemi.com)

---

**onsemi** and **onsemi** and other names, marks, and brands are registered and/or common law trademarks of Semiconductor Components Industries, LLC dba "**onsemi**" or its affiliates and/or subsidiaries in the United States and/or other countries. **onsemi** owns the rights to a number of patents, trademarks, copyrights, trade secrets, and other intellectual property. A listing of **onsemi** product/patent coverage may be accessed at [www.onsemi.com/site/pdf/Patent-Marking.pdf](http://www.onsemi.com/site/pdf/Patent-Marking.pdf). **onsemi** reserves the right to make changes at any time to any products or information herein, without notice. The information herein is provided "as-is" and **onsemi** makes no warranty, representation or guarantee regarding the accuracy of the information, product features, availability, functionality, or suitability of its products for any particular purpose, nor does **onsemi** assume any liability arising out of the application or use of any product or circuit, and specifically disclaims any and all liability, including without limitation special, consequential or incidental damages. Buyer is responsible for its products and applications using **onsemi** products, including compliance with all laws, regulations and safety requirements or standards, regardless of any support or applications information provided by **onsemi**. "Typical" parameters which may be provided in **onsemi** data sheets and/or specifications can and do vary in different applications and actual performance may vary over time. All operating parameters, including "Typicals" must be validated for each customer application by customer's technical experts. **onsemi** does not convey any license under any of its intellectual property rights nor the rights of others. **onsemi** products are not designed, intended, or authorized for use as a critical component in life support systems or any FDA Class 3 medical devices or medical devices with a same or similar classification in a foreign jurisdiction or any devices intended for implantation in the human body. Should Buyer purchase or use **onsemi** products for any such unintended or unauthorized application, Buyer shall indemnify and hold **onsemi** and its officers, employees, subsidiaries, affiliates, and distributors harmless against all claims, costs, damages, and expenses, and reasonable attorney fees arising out of, directly or indirectly, any claim of personal injury or death associated with such unintended or unauthorized use, even if such claim alleges that **onsemi** was negligent regarding the design or manufacture of the part. **onsemi** is an Equal Opportunity/Affirmative Action Employer. This literature is subject to all applicable copyright laws and is not for resale in any manner. Other names and brands may be claimed as the property of others.



ON Semiconductor®

# FQD4P25TM-WS

## P-Channel QFET® MOSFET

-250 V, -3.1 A, 2.1 Ω

### Description

This P-Channel enhancement mode power MOSFET is produced using ON Semiconductor's proprietary planar stripe and DMOS technology. This advanced MOSFET technology has been especially tailored to reduce on-state resistance, and to provide superior switching performance and high avalanche energy strength. These devices are suitable for switched mode power supplies, audio amplifier, DC motor control, and variable switching power applications.

### Features

- -3.1 A, -250 V,  $R_{DS(on)} = 2.1 \Omega$  (Max.) @  $V_{GS} = 10 \text{ V}$ ,  $I_D = -1.55 \text{ A}$
- Low Gate Charge (Typ. 10 nC)
- Low Crss (Typ. 10.3 pF)
- 100% Avalanche Tested
- Improved dv/dt Capability
- RoHS Compliant

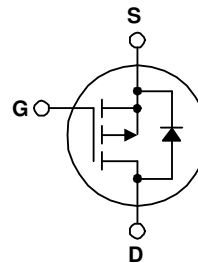
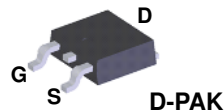

### Absolute Maximum Ratings $T_C = 25^\circ\text{C}$ unless otherwise noted.

| Symbol         | Parameter  | FQD4P25TM-WS | Unit                |
|----------------|--|--------------|---------------------|
| $V_{DSS}$      | Drain-Source Voltage   | -250         | V                   |
| $I_D$          | Drain Current - Continuous ( $T_C = 25^\circ\text{C}$ )              | -3.1         | A                   |
|                | - Continuous ( $T_C = 100^\circ\text{C}$ )                           | -1.96        | A                   |
| $I_{DM}$       | Drain Current - Pulsed (Note 1)                                      | -12.4        | A                   |
| $V_{GSS}$      | Gate-Source Voltage  | $\pm 30$     | V                   |
| $E_{AS}$       | Single Pulsed Avalanche Energy (Note 2)                              | 280          | mJ                  |
| $I_{AR}$       | Avalanche Current (Note 1)   | -3.1         | A                   |
| $E_{AR}$       | Repetitive Avalanche Energy (Note 1)                                 | 4.5          | mJ                  |
| dv/dt          | Peak Diode Recovery dv/dt (Note 3)                                   | -5.5         | V/ns                |
| $P_D$          | Power Dissipation ( $T_A = 25^\circ\text{C}$ ) *                     | 2.5          | W                   |
|                | Power Dissipation ( $T_C = 25^\circ\text{C}$ )                       | 45           | W                   |
|                | - Derate above $25^\circ\text{C}$                                    | 0.36         | W/ $^\circ\text{C}$ |
| $T_J, T_{STG}$ | Operating and Storage Temperature Range                              | -55 to +150  | $^\circ\text{C}$    |
| $T_L$          | Maximum lead temperature for soldering, 1/8" from case for 5 seconds | 300          | $^\circ\text{C}$    |

### Thermal Characteristics

| Symbol          | Parameter   | FQD4P25TM-WS | Unit                      |
|-----------------|---|--------------|---------------------------|
| $R_{\theta JC}$ | Thermal Resistance, Junction to Case, Max.  | 2.78         | $^\circ\text{C}/\text{W}$ |
| $R_{\theta JA}$ | Thermal Resistance, Junction to Ambient (Minimum Pad of 2-oz Copper), Max.            | 110          |                           |
|                 | Thermal Resistance, Junction to Ambient (*1 in <sup>2</sup> Pad of 2-oz Copper), Max. | 50           |                           |

## Package Marking and Ordering Information

| Part Number  | Top Mark | Package | Packing Method | Reel Size | Tape Width | Quantity   |
|--------------|----------|---------|----------------|-----------|------------|------------|
| FQD4P25TM-WS | FQD4P25S | DPAK    | Tape and Reel  | 330 mm    | 16 mm      | 2500 units |

## Electrical Characteristics

$T_C = 25^\circ\text{C}$  unless otherwise noted.

| Symbol | Parameter | Test Conditions | Min. | Typ. | Max. | Unit |
|--------|-----------|-----------------|------|------|------|------|
|--------|-----------|-----------------|------|------|------|------|

### Off Characteristics

|                                |   |  |      |       |      |                           |
|--------------------------------|---|--|------|-------|------|---------------------------|
| $BV_{DSS}$                     | Drain-Source Breakdown Voltage            | $V_{GS} = 0\text{ V}, I_D = -250\ \mu\text{A}$               | -250 | --    | --   | V                         |
| $\Delta BV_{DSS} / \Delta T_J$ | Breakdown Voltage Temperature Coefficient | $I_D = -250\ \mu\text{A}$ , Referenced to $25^\circ\text{C}$ | --   | -0.21 | --   | $\text{V}/^\circ\text{C}$ |
| $I_{DSS}$                      | Zero Gate Voltage Drain Current           | $V_{DS} = -250\text{ V}, V_{GS} = 0\text{ V}$                | --   | --    | -1   | $\mu\text{A}$             |
|                                |   | $V_{DS} = -200\text{ V}, T_C = 125^\circ\text{C}$            | --   | --    | -10  | $\mu\text{A}$             |
| $I_{GSSF}$                     | Gate-Body Leakage Current, Forward        | $V_{GS} = -30\text{ V}, V_{DS} = 0\text{ V}$                 | --   | --    | -100 | nA                        |
| $I_{GSSR}$                     | Gate-Body Leakage Current, Reverse        | $V_{GS} = 30\text{ V}, V_{DS} = 0\text{ V}$                  | --   | --    | 100  | nA                        |

### On Characteristics

|              |                                   |   |      |      |      |          |
|--------------|-----------------------------------|---|------|------|------|----------|
| $V_{GS(th)}$ | Gate Threshold Voltage            | $V_{DS} = V_{GS}, I_D = -250\ \mu\text{A}$    | -3.0 | --   | -5.0 | V        |
| $R_{DS(on)}$ | Static Drain-Source On-Resistance | $V_{GS} = -10\text{ V}, I_D = -1.55\text{ A}$ | --   | 1.63 | 2.1  | $\Omega$ |
| $g_{FS}$     | Forward Transconductance          | $V_{DS} = -40\text{ V}, I_D = -1.55\text{ A}$ | --   | 2.0  | --   | S        |

### Dynamic Characteristics

|           |                              |   |    |     |     |    |
|-----------|------------------------------|---|----|-----|-----|----|
| $C_{iss}$ | Input Capacitance            | $V_{DS} = -25\text{ V}, V_{GS} = 0\text{ V},$<br>$f = 1.0\text{ MHz}$ | -- | 325 | 420 | pF |
| $C_{oss}$ | Output Capacitance           |   | -- | 65  | 85  | pF |
| $C_{rss}$ | Reverse Transfer Capacitance |   | -- | 10  | 13  | pF |

### Switching Characteristics

|              |                     |   |          |      |     |    |    |
|--------------|---------------------|---|----------|------|-----|----|----|
| $t_{d(on)}$  | Turn-On Delay Time  | $V_{DD} = -125\text{ V}, I_D = -4.0\text{ A},$<br>$R_G = 25\ \Omega$      | --       | 9.5  | 30  | ns |    |
| $t_r$        | Turn-On Rise Time   |   | --       | 60   | 130 | ns |    |
| $t_{d(off)}$ | Turn-Off Delay Time |   | (Note 4) | --   | 14  | 40 | ns |
| $t_f$        | Turn-Off Fall Time  |   | (Note 4) | --   | 27  | 65 | ns |
| $Q_g$        | Total Gate Charge   | $V_{DS} = -200\text{ V}, I_D = -4.0\text{ A},$<br>$V_{GS} = -10\text{ V}$ | --       | 10.3 | 14  | nC |    |
| $Q_{gs}$     | Gate-Source Charge  |   | (Note 4) | --   | 2.7 | -- | nC |
| $Q_{gd}$     | Gate-Drain Charge   |   | (Note 4) | --   | 5.2 | -- | nC |

### Drain-Source Diode Characteristics and Maximum Ratings

|          |   |   |    |       |      |               |
|----------|---|---|----|-------|------|---------------|
| $I_S$    | Maximum Continuous Drain-Source Diode Forward Current | --  | -- | -3.1  | A    |               |
| $I_{SM}$ | Maximum Pulsed Drain-Source Diode Forward Current     | --  | -- | -12.4 | A    |               |
| $V_{SD}$ | Drain-Source Diode Forward Voltage                    | $V_{GS} = 0\text{ V}, I_S = -3.1\text{ A}$  | -- | --    | -5.0 | V             |
| $t_{rr}$ | Reverse Recovery Time                                 | $V_{GS} = 0\text{ V}, I_S = -4.0\text{ A},$<br>$di_F / dt = 100\text{ A}/\mu\text{s}$ | -- | 140   | --   | ns            |
| $Q_{rr}$ | Reverse Recovery Charge                               |   | -- | 0.64  | --   | $\mu\text{C}$ |

#### Notes:

1. Repetitive rating : pulse-width limited by maximum Junction temperature.
2.  $L = 46.6\text{ mH}, I_{AS} = -3.1\text{ A}, V_{DD} = -50\text{ V}, R_G = 25\ \Omega$ , starting  $T_J = 25^\circ\text{C}$ .
3.  $I_{SD} \leq -4.0\text{ A}, di_V/dt \leq 300\text{ AV}/\mu\text{s}, V_{DD} \leq BV_{DSS}$ , starting  $T_J = 25^\circ\text{C}$ .
4. Essentially independent of operating temperature.

## Typical Characteristics

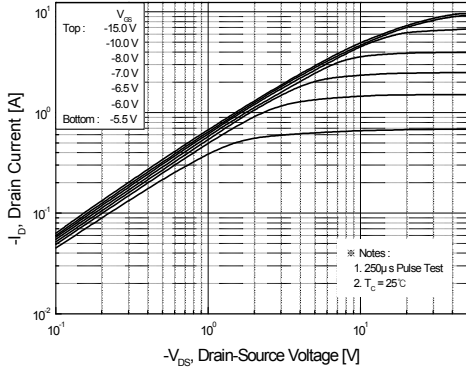

Figure 1. On-Region Characteristics

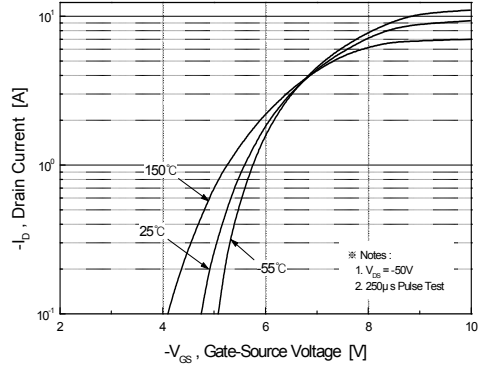

Figure 2. Transfer Characteristics

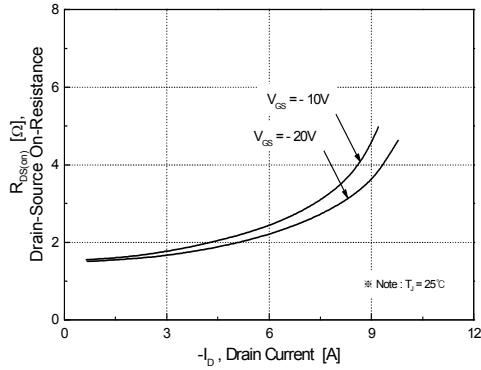

Figure 3. On-Resistance Variation vs. Drain Current and Gate Voltage

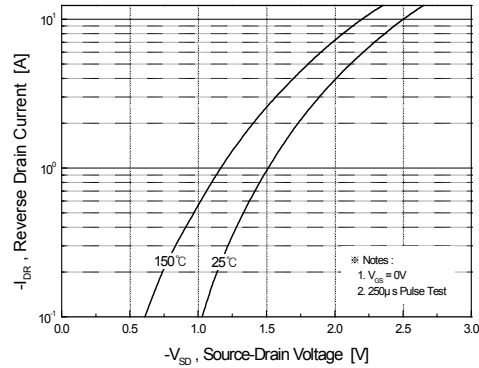

Figure 4. Body Diode Forward Voltage Variation vs. Source Current and Temperature

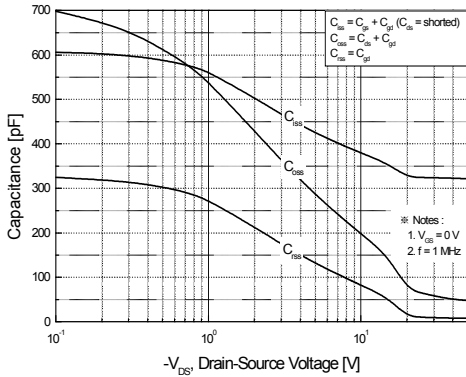

Figure 5. Capacitance Characteristics

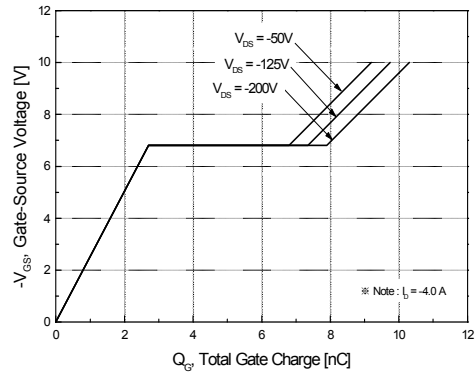
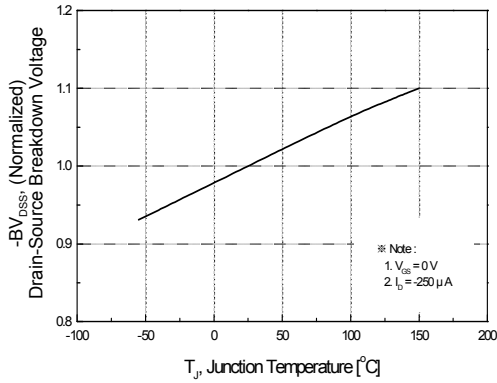
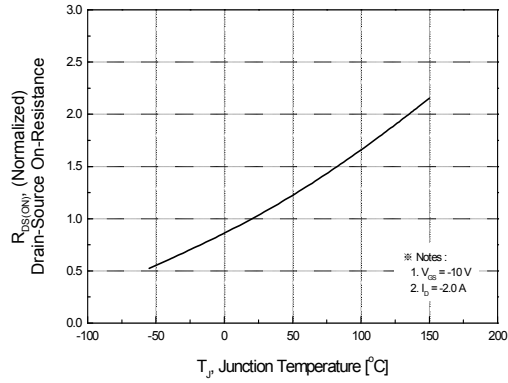

Figure 6. Gate Charge Characteristics

**Typical Characteristics** (Continued)



**Figure 7. Breakdown Voltage Variation vs. Temperature**



**Figure 8. On-Resistance Variation vs. Temperature**

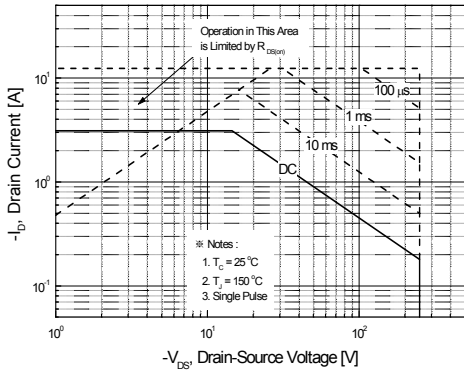

**Figure 9. Maximum Safe Operating Area**

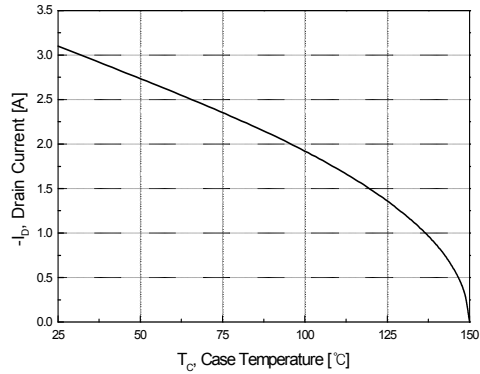

**Figure 10. Maximum Drain Current vs. Case Temperature**

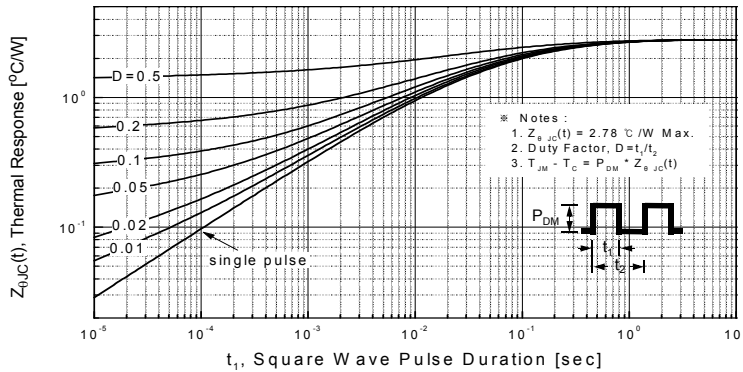

**Figure 11. Transient Thermal Response Curve**

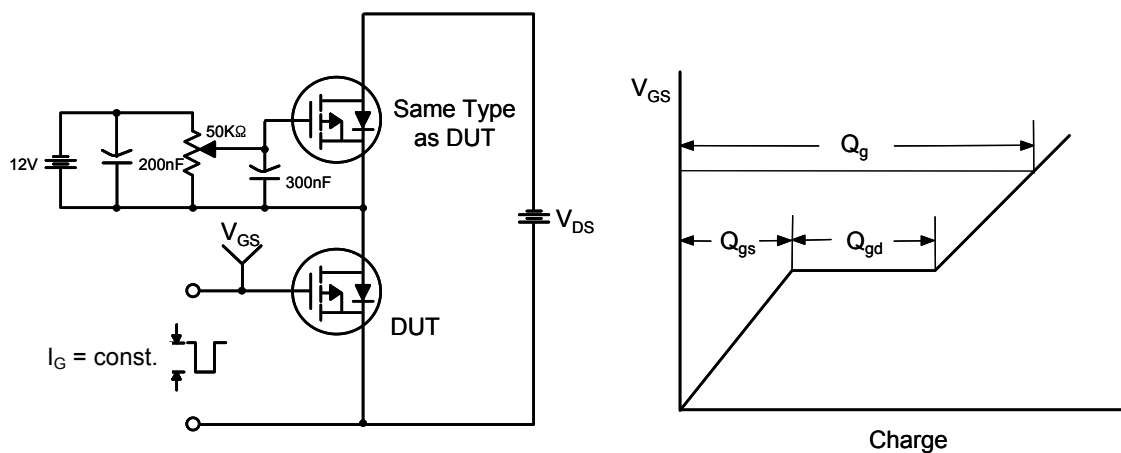

Figure 12. Gate Charge Test Circuit & Waveform

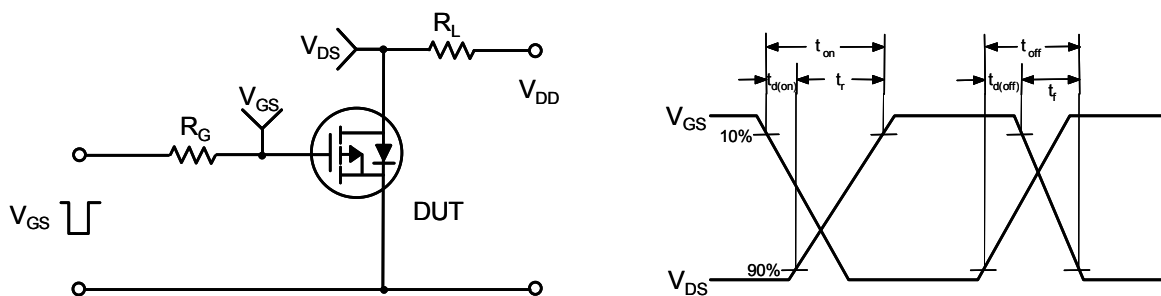

Figure 13. Resistive Switching Test Circuit & Waveforms

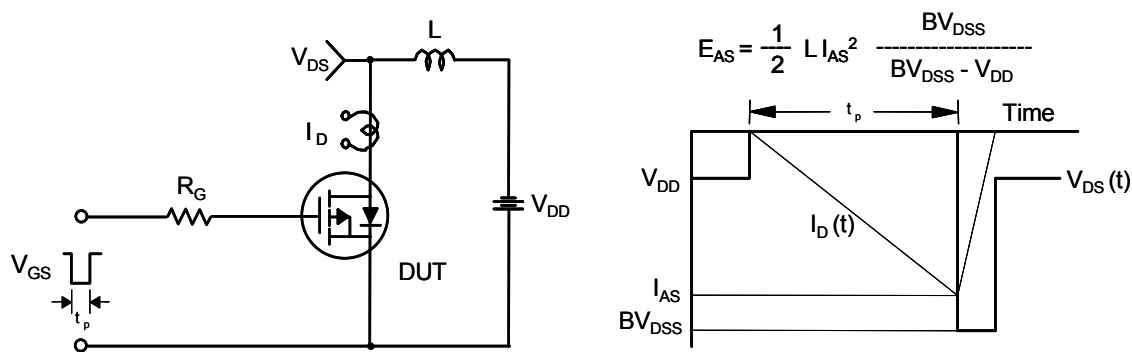

Figure 14. Unclamped Inductive Switching Test Circuit & Waveforms

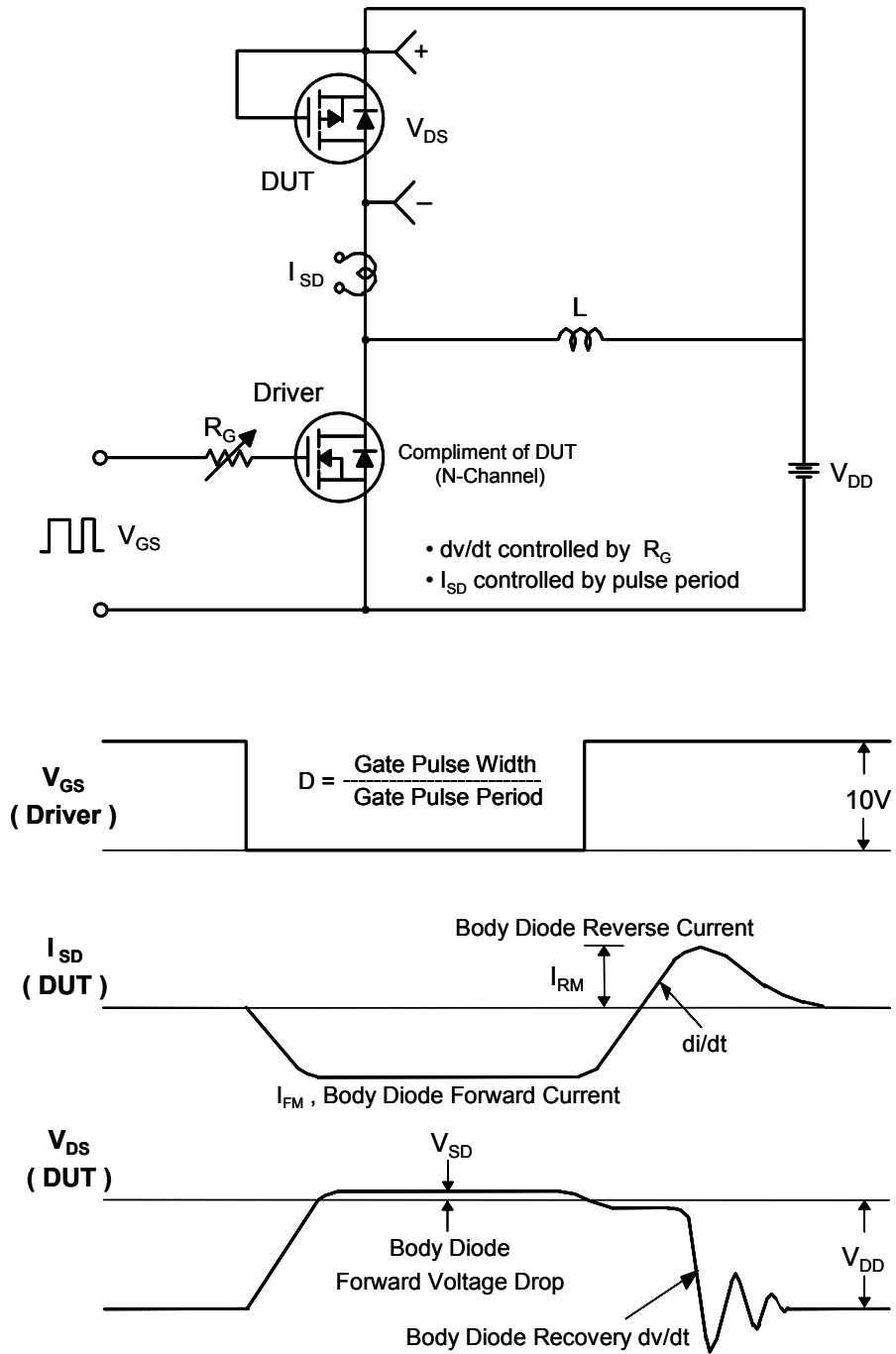
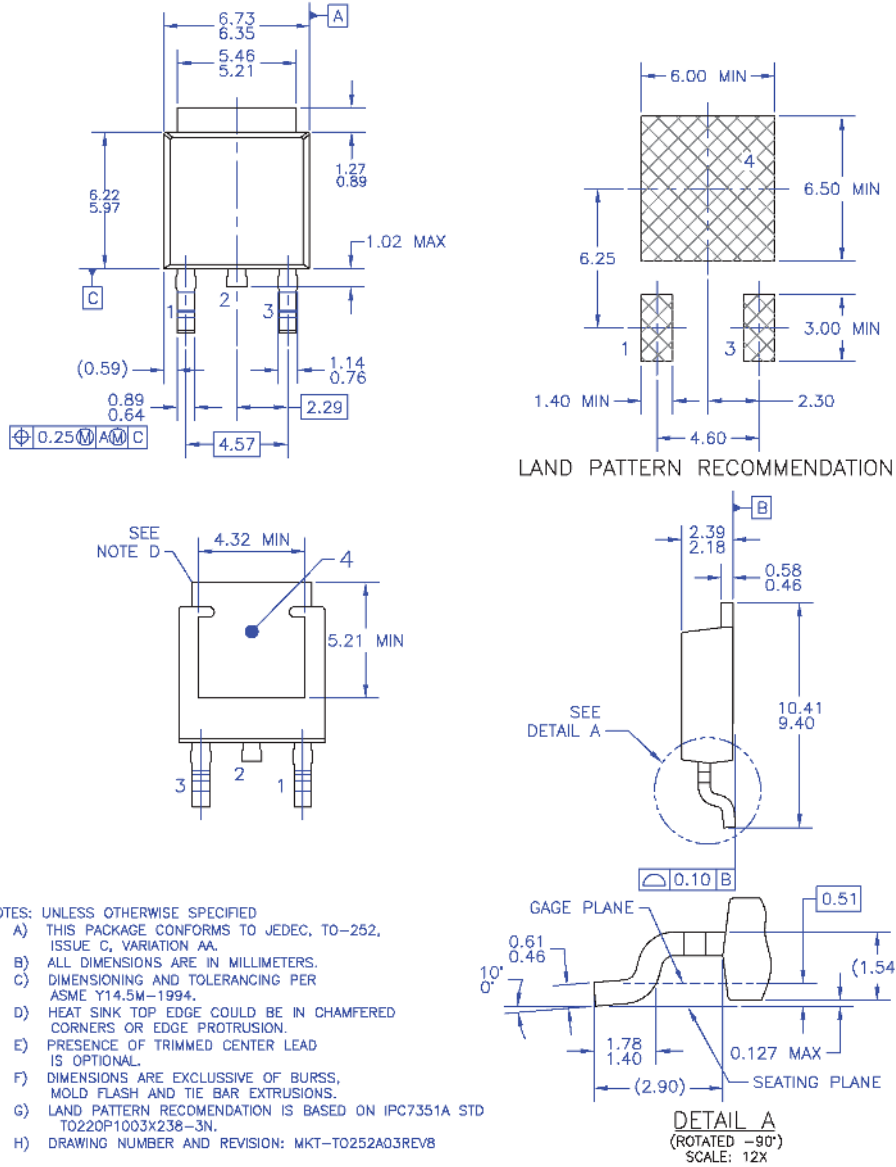

Figure 15. Peak Diode Recovery  $dv/dt$  Test Circuit & Waveforms

## Mechanical Dimensions



**Figure 16. TO252 (D-PAK), Molded, 3-Lead, Option AA&AB**

Package drawings are provided as a service to customers considering ON Semiconductor components. Drawings may change in any manner without notice. Please note the revision and/or date on the drawing and contact a ON Semiconductor's representative to verify or obtain the most recent revision. Package specifications do not expand the terms of ON Semiconductor's worldwide terms and conditions, specifically the warranty therein, which covers ON Semiconductor products.



ON Semiconductor and  are trademarks of Semiconductor Components Industries, LLC dba ON Semiconductor or its subsidiaries in the United States and/or other countries. ON Semiconductor owns the rights to a number of patents, trademarks, copyrights, trade secrets, and other intellectual property. A listing of ON Semiconductor's product/patent coverage may be accessed at [www.onsemi.com/site/pdf/Patent-Marking.pdf](http://www.onsemi.com/site/pdf/Patent-Marking.pdf). ON Semiconductor reserves the right to make changes without further notice to any products herein. ON Semiconductor makes no warranty, representation or guarantee regarding the suitability of its products for any particular purpose, nor does ON Semiconductor assume any liability arising out of the application or use of any product or circuit, and specifically disclaims any and all liability, including without limitation special, consequential or incidental damages. Buyer is responsible for its products and applications using ON Semiconductor products, including compliance with all laws, regulations and safety requirements or standards, regardless of any support or applications information provided by ON Semiconductor. "Typical" parameters which may be provided in ON Semiconductor data sheets and/or specifications can and do vary in different applications and actual performance may vary over time. All operating parameters, including "Typicals" must be validated for each customer application by customer's technical experts. ON Semiconductor does not convey any license under its patent rights nor the rights of others. ON Semiconductor products are not designed, intended, or authorized for use as a critical component in life support systems or any FDA Class 3 medical devices or medical devices with a same or similar classification in a foreign jurisdiction or any devices intended for implantation in the human body. Should Buyer purchase or use ON Semiconductor products for any such unintended or unauthorized application, Buyer shall indemnify and hold ON Semiconductor and its officers, employees, subsidiaries, affiliates, and distributors harmless against all claims, costs, damages, and expenses, and reasonable attorney fees arising out of, directly or indirectly, any claim of personal injury or death associated with such unintended or unauthorized use, even if such claim alleges that ON Semiconductor was negligent regarding the design or manufacture of the part. ON Semiconductor is an Equal Opportunity/Affirmative Action Employer. This literature is subject to all applicable copyright laws and is not for resale in any manner.

**PUBLICATION ORDERING INFORMATION**

**LITERATURE FULFILLMENT:**

Literature Distribution Center for ON Semiconductor  
 19521 E. 32nd Pkwy, Aurora, Colorado 80011 USA  
**Phone:** 303-675-2175 or 800-344-3860 Toll Free USA/Canada  
**Fax:** 303-675-2176 or 800-344-3867 Toll Free USA/Canada  
**Email:** [orderlit@onsemi.com](mailto:orderlit@onsemi.com)

**N. American Technical Support:** 800-282-9855 Toll Free  
 USA/Canada  
**Europe, Middle East and Africa Technical Support:**  
 Phone: 421 33 790 2910  
**Japan Customer Focus Center**  
 Phone: 81-3-5817-1050

**ON Semiconductor Website:** [www.onsemi.com](http://www.onsemi.com)  
**Order Literature:** <http://www.onsemi.com/orderlit>  
 For additional information, please contact your local  
 Sales Representative