

DRAWING REVISIONS

REV	DOCUMENT	APP	DATE
1	DO 06-1068		

PART NUMBER	SIZE	L	M	A	FACTORY NUMBER
P-2404H-AB	4	2.031 [51.59]	1.625 [41.28]	1.000 [25.40]	703 03 04 001
P-2406H-AB	6	2.469 [62.71]	2.063 [52.40]	1.438 [36.53]	703 03 06 001
P-2408H-AB	8	2.906 [73.81]	2.500 [63.50]	1.875 [47.63]	703 03 08 001
P-2410H-AB	10	3.344 [84.94]	2.938 [74.63]	2.313 [58.75]	703 03 10 001
P-2412H-AB	12	3.781 [96.04]	3.375 [85.73]	2.750 [69.85]	703 03 12 001

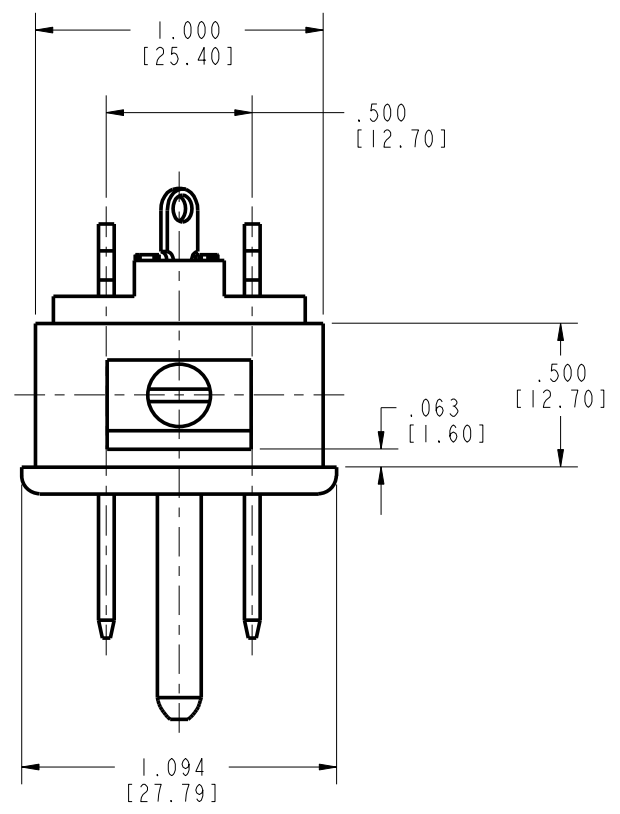
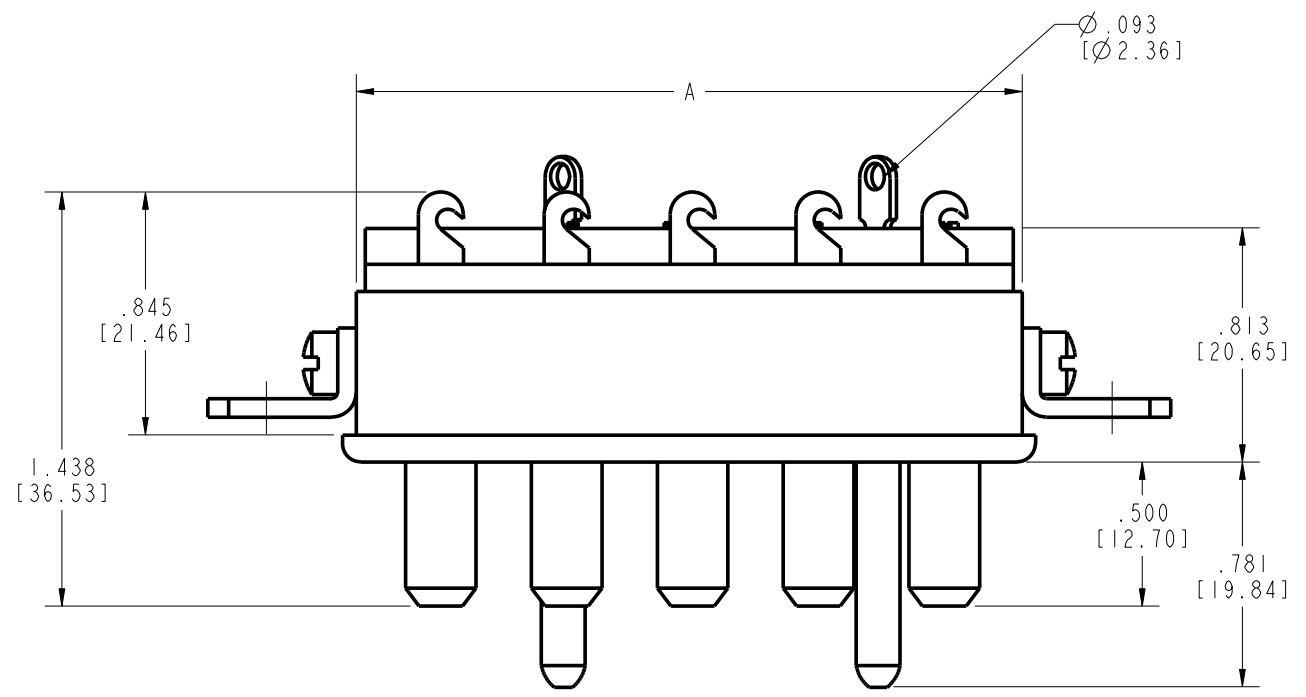
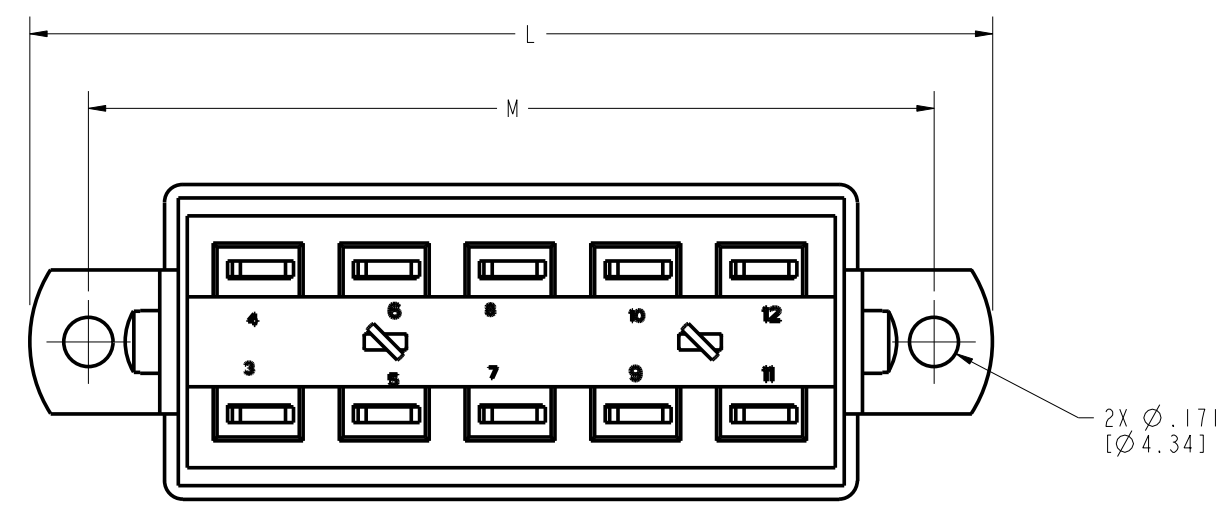

NOTES:
 1. SPECIFICATIONS:
 ELECTRICAL:
 OPERATING VOLTAGE: 250 VAC RMS
 CURRENT RATING: 15 AMPS
 CURRENT RESISTANCE: 1.0 MILLIOHMS MAXIMUM

INSULATOR: MOLDED MONBLOCK, GENERAL PURPOSE PHENOLIC, BLACK
 CONTACT: BRASS, MATTE TIN
 BRACKET, SCREW: STEEL, ZINC WITH CLEAR TRVALENT CHROME
 ENVIRONMENTAL:
 OPERATING TEMPERATURE: UP TO +105°C
 TERMINATION: SOLDER

2. DIMENSIONS IN [] ARE MILLIMETERS
 3. ALL DIMENSIONS ARE REFERENCE

RoHS COMPLIANT

MODELED BY:
JIMENEZ

UNITS ENGLISH INCHES	PRO/E	Cinch		1700 FINLEY RD LOMBARD, IL. 60148
DO NOT SCALE DRAWING	DESIGNED BY JIMENEZ	DATE 7/31/06	TITLE PLUG AND ANGLE BRACKET ASSEMBLY	
UNLESS OTHERWISE SPECIFIED: ALL DIMENSIONS ARE IN INCHES FILLET/RADIUS .02 MAX TOLERANCES XXX ± .01 .XXX ± .005 ANGULAR ± .5°	DESIGN ENGINEER A. BALI	7/31/06	CONTROL SPEC NUMBER 06-1068	
	DESIGN ENGINEERING MGR.		PROJECT NUMBER C14789-2	
THIS DOCUMENT IS THE PROPERTY OF CINCH. NEITHER THIS DOCUMENT NOR ANY OF THE INFORMATION CONTAINED IN IT MAY BE DUPLICATED OR DISCLOSED WITHOUT PRIOR WRITTEN CONSENT OF CINCH.	MFG. ENGINEERING	CAD FILE NUMBER P2404HAB	DRAWING NUMBER P-2404H-AB	
	QUALITY ASSURANCE	CAGE IDENT NO. SIZE 71785 B	SCALE 1.000	SHEET 1 OF 1