

# Model 51

# STA<sup>®</sup> Push DC Tubular Solenoid

Size: ½" OD X 1" L

ALL PRODUCTS ARE RoHS COMPLIANT

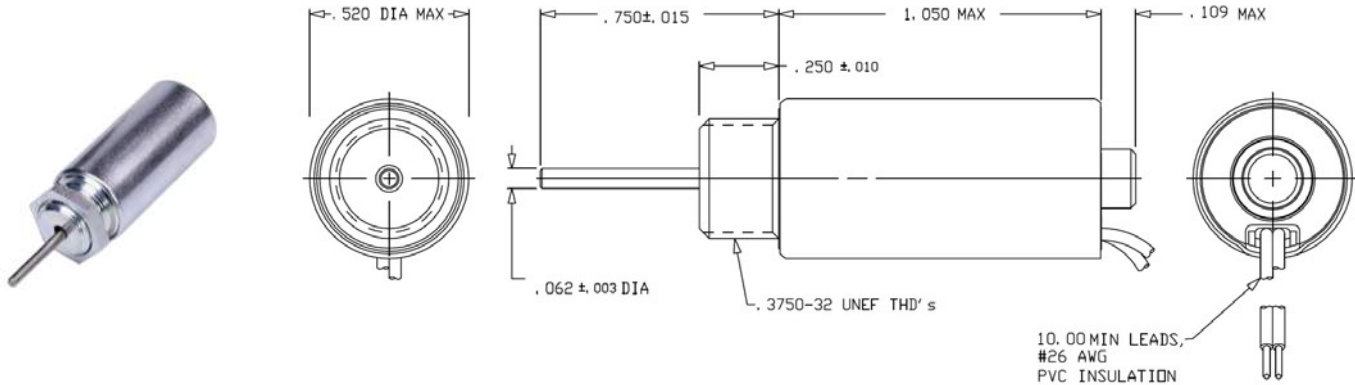

Solenoid shown energized with plunger fully seated  
 Supplied with hex nut shipped loose  
 Spring kits available (consult factory)

Part No.	Duty Cycle	Voltage	Resistance (Ω) ± 5%	Max On Time	Power (W)	Current (A)
195203-231	Intermittent	12 VDC	9.56	5 Secs	15.1	1.26
195203-234	Continuous	12 VDC	37.41	∞	3.9	0.32
195203-234	Intermittent	24 VDC	37.41	5 Secs	15.4	0.64
195203-237	Continuous	24 VDC	141.93	∞	4.1	0.17

Continuous Duty = 100% "On" Time  
 Intermittent Duty = 25% "On" Time  
 When ordering please refer to Part No. as listed above  
 Please consult factory for custom configurations and other pole face angles

Stroke (in.)	Typical Push Force (oz.)								Holding Force (oz.)
	0.050	0.100	0.150	0.200	0.250	0.300	0.350	0.400	
Continuous Duty	4.0	2.4	1.4	0.8	0.4	N/A	N/A	N/A	11.4
Intermittent Duty	11.6	7.2	5.0	3.6	2.6	2.0	1.6	1.0	N/A

### Additional Specifications:

Dielectric Strength: 500 VRMS  
 Recommended Heat Sink: Maximum watts dissipated by solenoid are based on an unrestricted flow of air at 20°C, with solenoid mounted to the equivalent of an aluminum plate measuring 2" square by 1/8" thick.  
 Total Unit Weight: 0.89 oz. / 25.2 g  
 Plunger Weight: 0.11 oz. / 3.1 g