

NOTE:

MATERIAL

HOUSING	PBT UL94V-0, BLACK
FLANGE	PBT UL94V-0, BLACK
CONTACT	BRASS, PLATING P/N KEY BELOW
SHELL	STEEL, NICKEL
O-RING	SILICONE
SEALING COMPOUND	EPOXY
HARDWARE	BRASS; NICKEL PLATED

ELECTRICAL

RATED CURRENT	3A
VOLTAGE	1000 VAC 1 MIN
INSULATOR RESISTANCE	5 GOhms MIN.
CONTACT RESISTANCE	10 mOhms MAX.
WATER PROOF	IP67

ENVIRONMENT

OPERATION TEMPERATURE	-25°C TO +85°C
-----------------------	----------------

DIMENSIONS(mm)			
SIZE	A	B	C
15	39.50	25.00	16.90
26	48.00	33.30	25.25
44	61.50	47.05	38.95
62	77.80	63.50	55.40

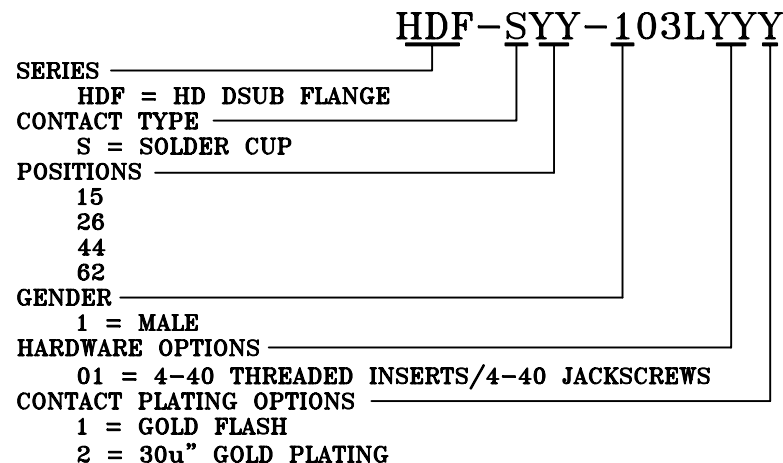
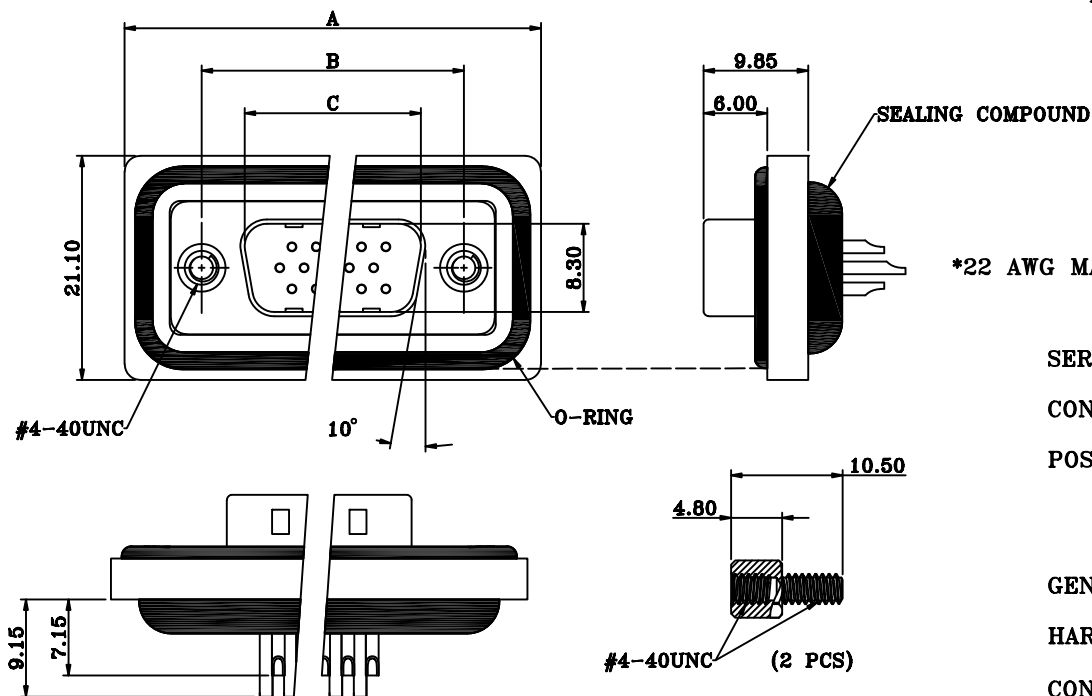

RoHS COMPLIANT



THESE DRAWINGS AND SPECIFICATIONS ARE THE PROPERTY OF NorComp AND SHALL NOT BE REPRODUCED, COPIED OR USED AS THE BASIS FOR THE MANUFACTURE OR SALE OF APPARATUS WITHOUT WRITTEN PERMISSION.

DRAWN: J. KADEL
DATE: 03/02/2020

TOLERANCES
X. ±0.40
.X ±0.30
.XX ±0.20
.XXX ±0.10

UNITS = mm

DO NOT SCALE FROM DRAWING

NorComp

SCALE: NTS	SHEET 1 OF 1	REV 0
DWG NO. HDF-SYY-103LYYY		