

The TLE 7201R is an Application Specific Standard Product (ASSP) for automotive door-module applications. It includes all the power stages necessary to drive the loads in a typical front door application, i.e. central lock, deadlock or mirror fold, mirror position, mirror defrost and up to four 5 W lamps, e.g. for turn signal, courtesy/warning or control panel illumination. It is designed as a monolithic circuit, using Infineon's mixed technology SPT which combines bipolar and CMOS control circuitry with DMOS power devices.

Short circuit and over-temperature protection and a detailed diagnosis are in line with the safety requirements of automotive applications. The current sense output allows to improve the total system performance. The standard SPI interface saves microcontroller I/O lines while still giving flexible control of the power stages and a detailed diagnosis.



TLE 7201R

Applications

- Automotive Front-Door Modules
- Automotive Body ECUs including door functionality

Features

- Full bridge (150 mΩ) for main doorlock motor
- Two half-bridges (400 mΩ) for deadbolt and mirror position motor or mirror fold motor
- Two half-bridges (800 mΩ) for mirror position
- High-side switch (100 mΩ) for mirror defrost
- Four high-side switches (500 mΩ) for 5 W lamps

- Analog current sense output and build-in multiplexer to reduce ADC-channels of the microcontroller
- All outputs with short circuit protection and diagnosis
- Over-temperature protection with warning
- Open load diagnosis for all outputs
- Charge-pump output for n-channel MOSFET for reverse-polarity protection
- Very low current consumption in sleep mode
- Standard 16-bit SPI for control and diagnosis
- Over- and Undervoltage Lockout

- Power-SO package with full-size heatslug for excellent thermal resistance
- Pinning optimized for efficient PCB layout

P-DSO-36-12



TLE 7201R

Power ASSP for
Automotive Door-Zone Modules



Never stop thinking.

Block Diagram

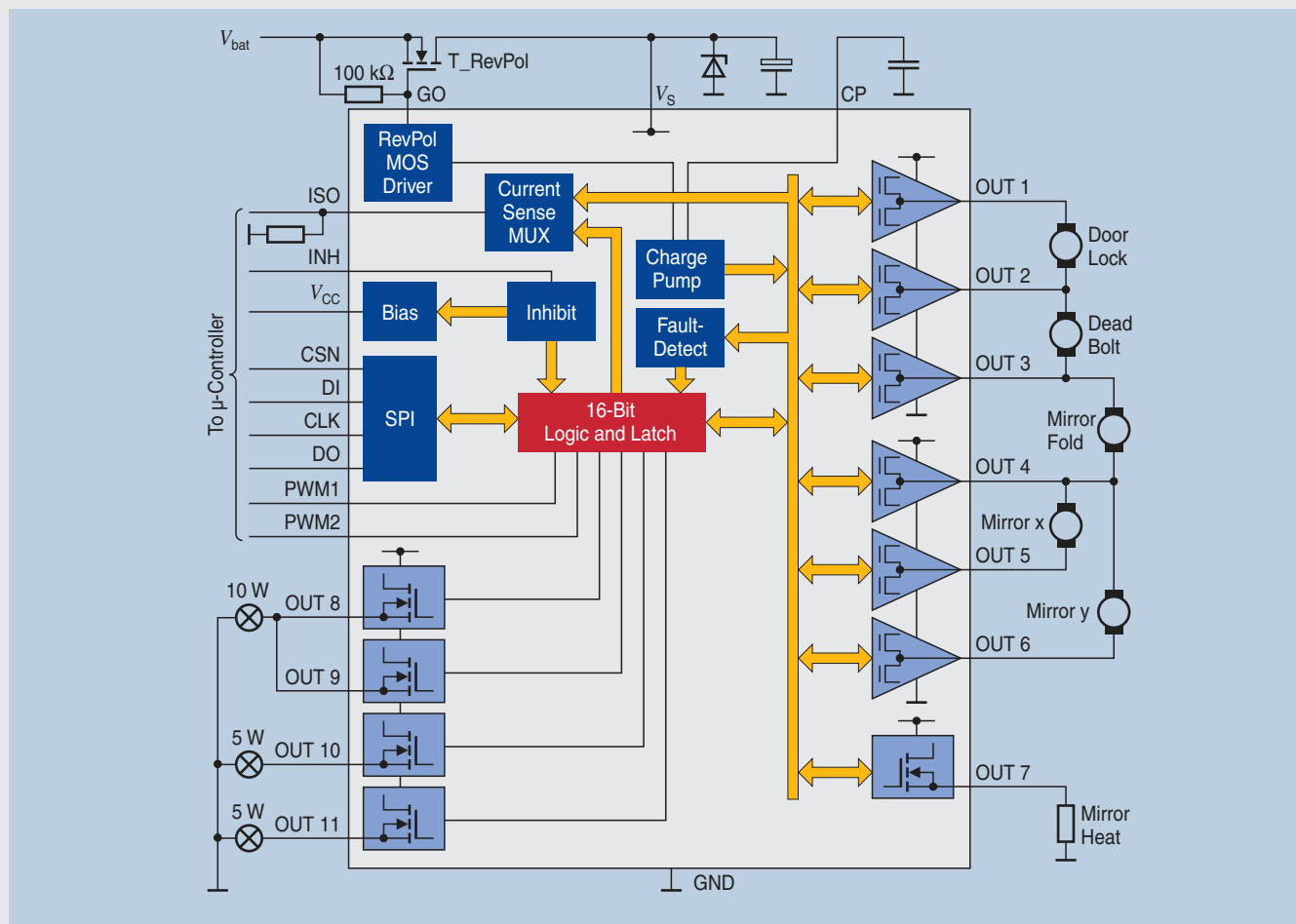

Besides the TLE 7201R, Infineon offers a broad range of products suitable for door-module application

Type	Description	Package
TLE 7201R	Power ASSP for lock, mirror and lamps	P-DSO-36-12
TLE 6266	Door-Module System ASSP with CAN, V-reg and relay-driver	P-DSO-28
TLE 6263	General purpose System Base Chip with CAN, V-reg and wake-inputs	P-DSO-28
BTS 7740G	H-bridge for door-lock	P-DSO-28
BTS 781GP	H-bridge for window-lift	P-TO263-15
TLE 6208-3G	Triple half-bridge for mirror position	P-DSO-14
BTS 5210G	2-Channel high-side switch for lamps, mirror heater	P-DSO-14
BTS 716G	4-Channel high-side switch for lamps, mirror heater	P-DSO-20
TLE 4240	LED-driver with current control and diagnosis	P-DSO-8
C164CM	16-bit microcontroller with 32 K ROM/OTP, CAN	P-TQFP-64
XC164CS	16-bit microcontroller with 64 - 128 K ROM/Flash, TwinCAN	P-TQFP-100
TLE 49x5G	Hall-switch for window-lift rotational indexing	SOT89

How to reach us:
<http://www.infineon.com>

Published by
 Infineon Technologies AG,
 St.-Martin-Strasse 53,
 81669 München

© Infineon Technologies AG 2002. All Rights Reserved.

Attention please!

The information herein is given to describe certain components and shall not be considered as warranted characteristics.

Terms of delivery and rights to technical change reserved.

We hereby disclaim any and all warranties, including but not limited to warranties of non-infringement, regarding circuits, descriptions and charts stated herein.

Infineon Technologies is an approved CECC manufacturer.

Information

For further information on technology, delivery terms and conditions and prices please contact your nearest Infineon Technologies Office in Germany or our Infineon Technologies Representatives worldwide.

Warnings

Due to technical requirements components may contain dangerous substances. For information on the types in question please contact your nearest Infineon Technologies Office.

Infineon Technologies Components may only be used in life-support devices or systems with the express written approval of Infineon Technologies, if a failure of such components can reasonably be expected to cause the failure of that life-support device or system, or to affect the safety or effectiveness of that device or system. Life-support devices or systems are intended to be implanted in the human body, or to support and/or maintain and sustain and/or protect human life. If they fail, it is reasonable to assume that the health of the user or other persons may be endangered.