

THIS DRAWING IS UNPUBLISHED. RELEASED FOR PUBLICATION, 19  
 © COPYRIGHT 19 BY AMP INCORPORATED. ALL INTERNATIONAL RIGHTS RESERVED.

PROD 4085 CODE	LOC DF	DIST SO	P	F	REVISIONS				DATE	APPD
					ZONE	LTR	DESCRIPTION			
						B	REV PER ECO 06-14737 CT	6-22-06	DE	

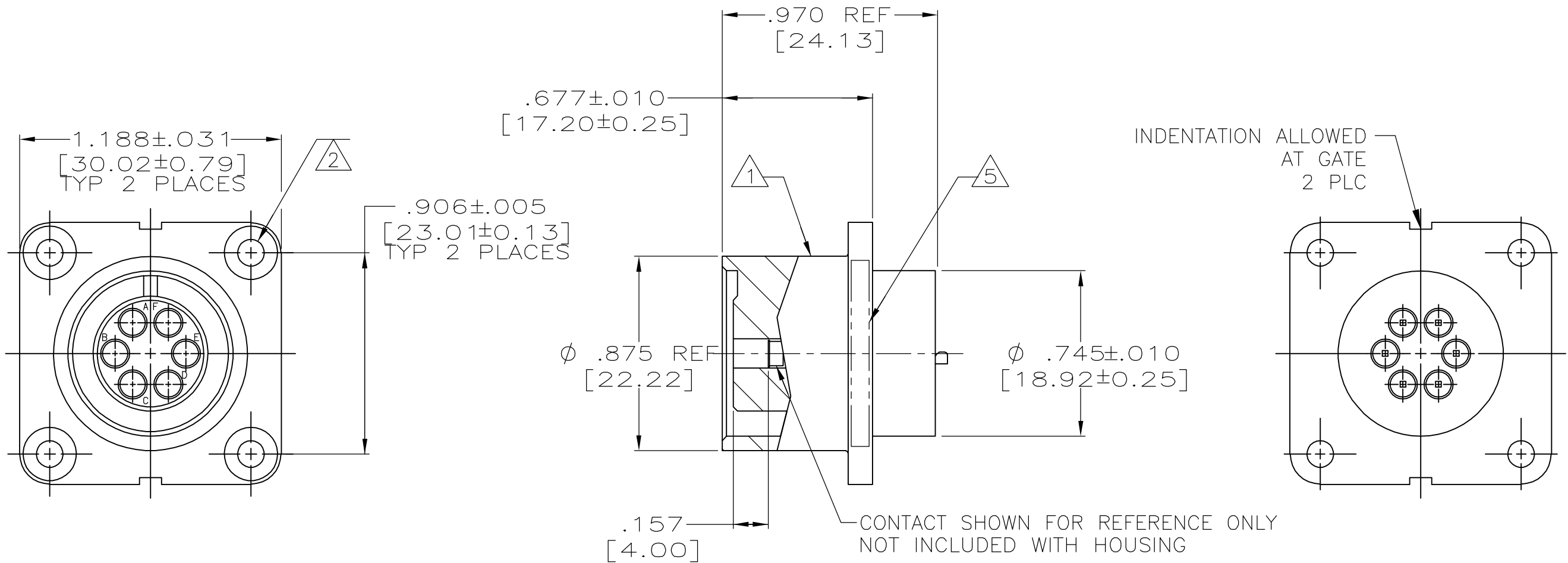

- 1 HOUSING IS NOT PROVIDED WITH THREADED FRONT SKIRT.
- 2  $\phi .120^{+.005}_{-.001}$  HOLE WITH  $82^\circ$  X  $\phi .243^{+.005}_{-.001}$  CSINK  
 $[3.05^{+0.13}_{-0.03}]$   $[3.05^{+0.13}_{-0.03}]$   
 4 PLACES
- 3. RECEPTACLE INTERFACE IS THE SAME AS MS 3102A-14S-6S EXCEPT  $\phi .875 [22.23]$  IS NOT THREADED.
- 4. AMP DOES NOT MANUFACTURE THE MATING PLUG AND IS NOT RESPONSIBLE FOR PIN AND SOCKET ENGAGEMENT.
- 5 MARKED PER MIL-STD-130.

1218081-1  
PART NO

DO NOT SCALE PRINT. UNLESS SPECIFIED DIMENSIONS IN INCHES [mm] TOLERANCES ON: 2 PLC DEC ± .01 [0.25] 3 PLC DEC ± .005 [0.13] ANGLES ± _____	DR 10-14-97 C.C.THOMAS	<b>AMP</b> AMP Incorporated Harrisburg, PA 17105-3608
	CHK 10-16-97 D. EABY	
	APPD 10-16-97 D. EABY	
	RLSE 10-16-97 C.C.THOMAS	
MATERIAL HOUSING: BLACK POLYESTER THERMO PLASTIC	PRODUCT SPEC -	NAME RCPT HOUSING, 6 POSN., LGH, SPECIAL 4mm RECESS
FINISH _____	APPLICATION SPEC -	SIZE <b>B</b>
	WEIGHT -	CAGE CODE 00779
		DRAWING NO 1218081
		SCALE 2:1
		SHEET 1 OF 1