

REVISIONS						
LOC	DIST	P. LTH	DESCRIPTION	DATE	DWN	APVD
-	-	A	RELEASED PER ECO 13-014393	9-16-13	CT	WM
					STM	STM

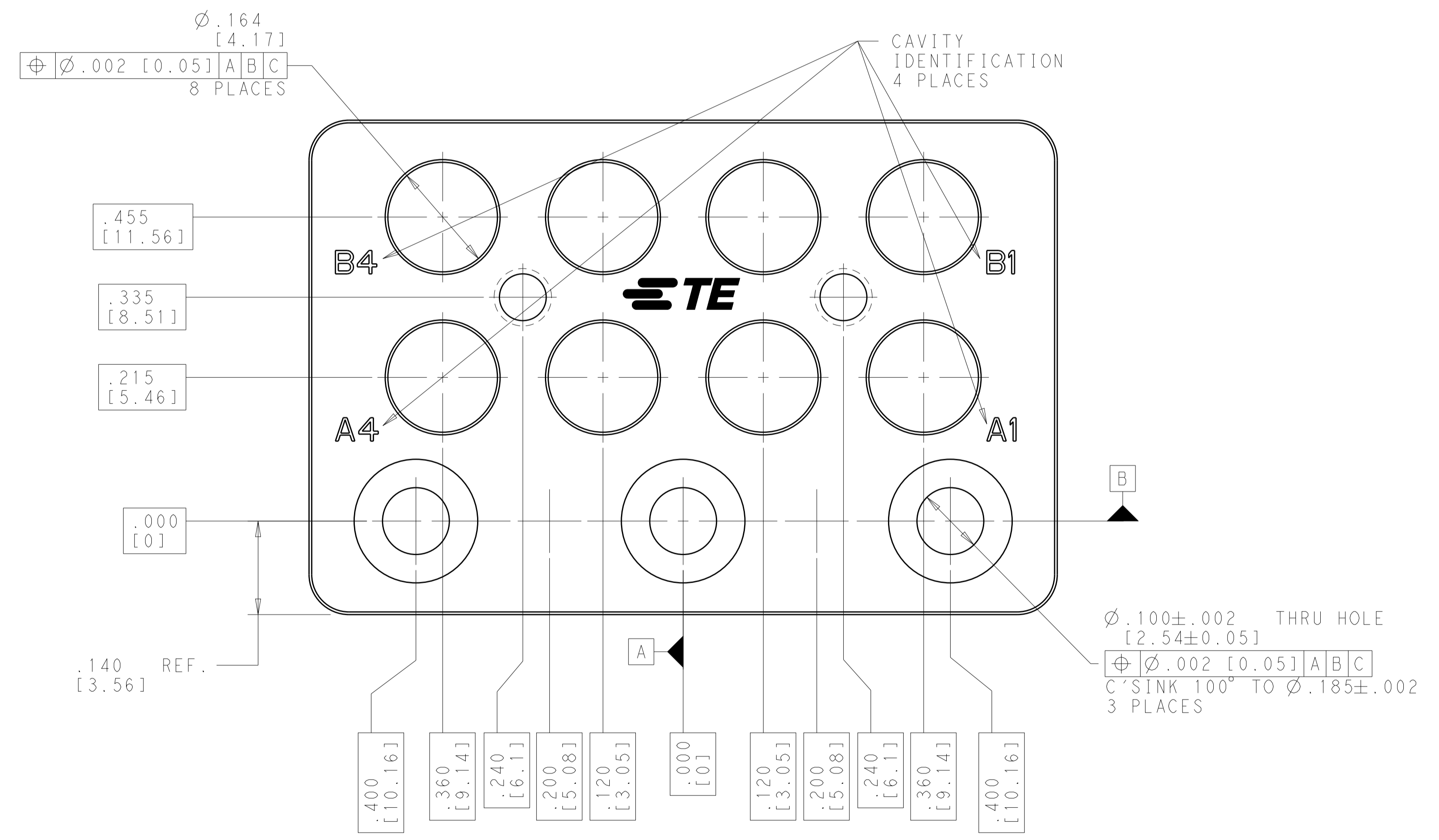
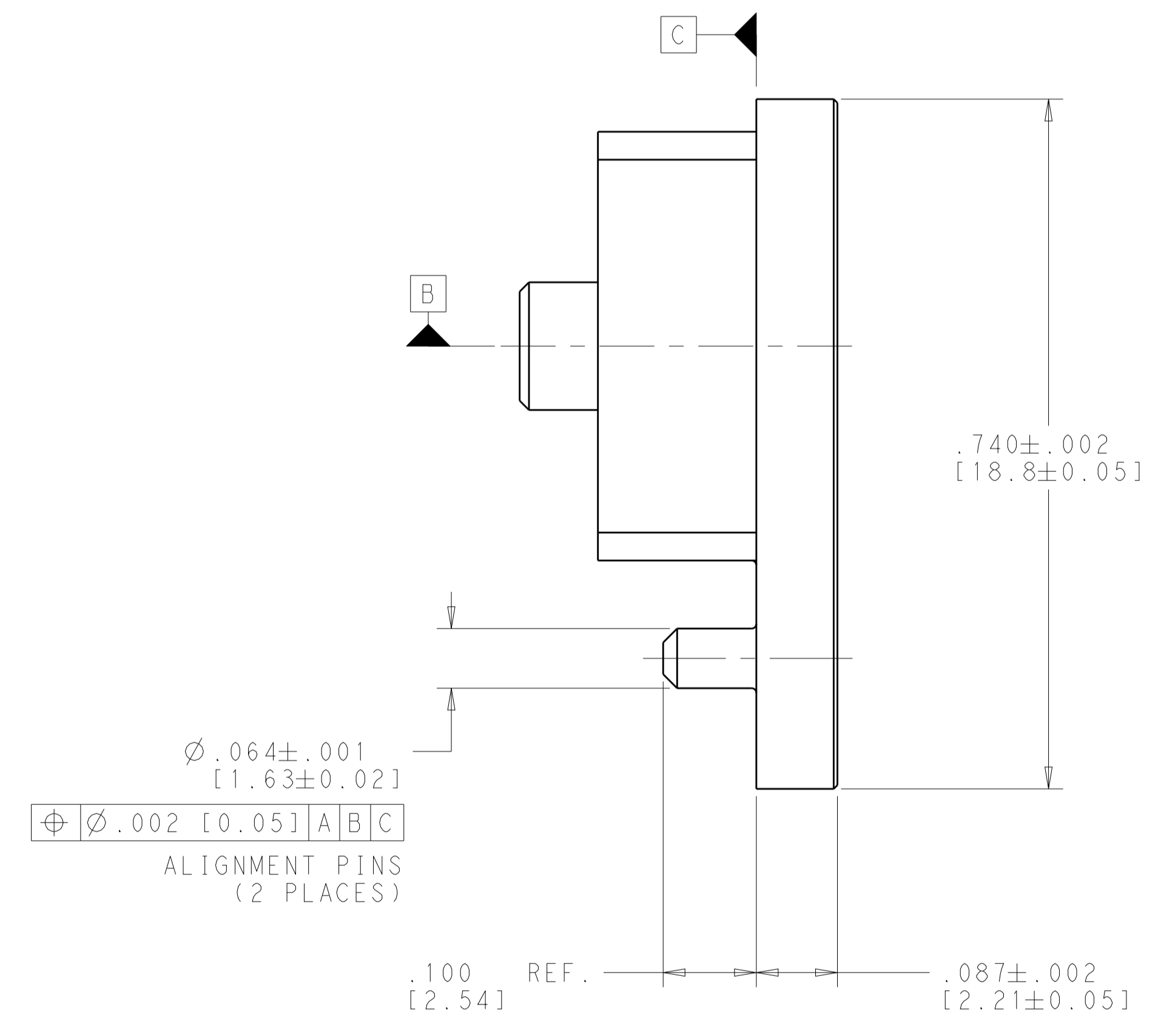
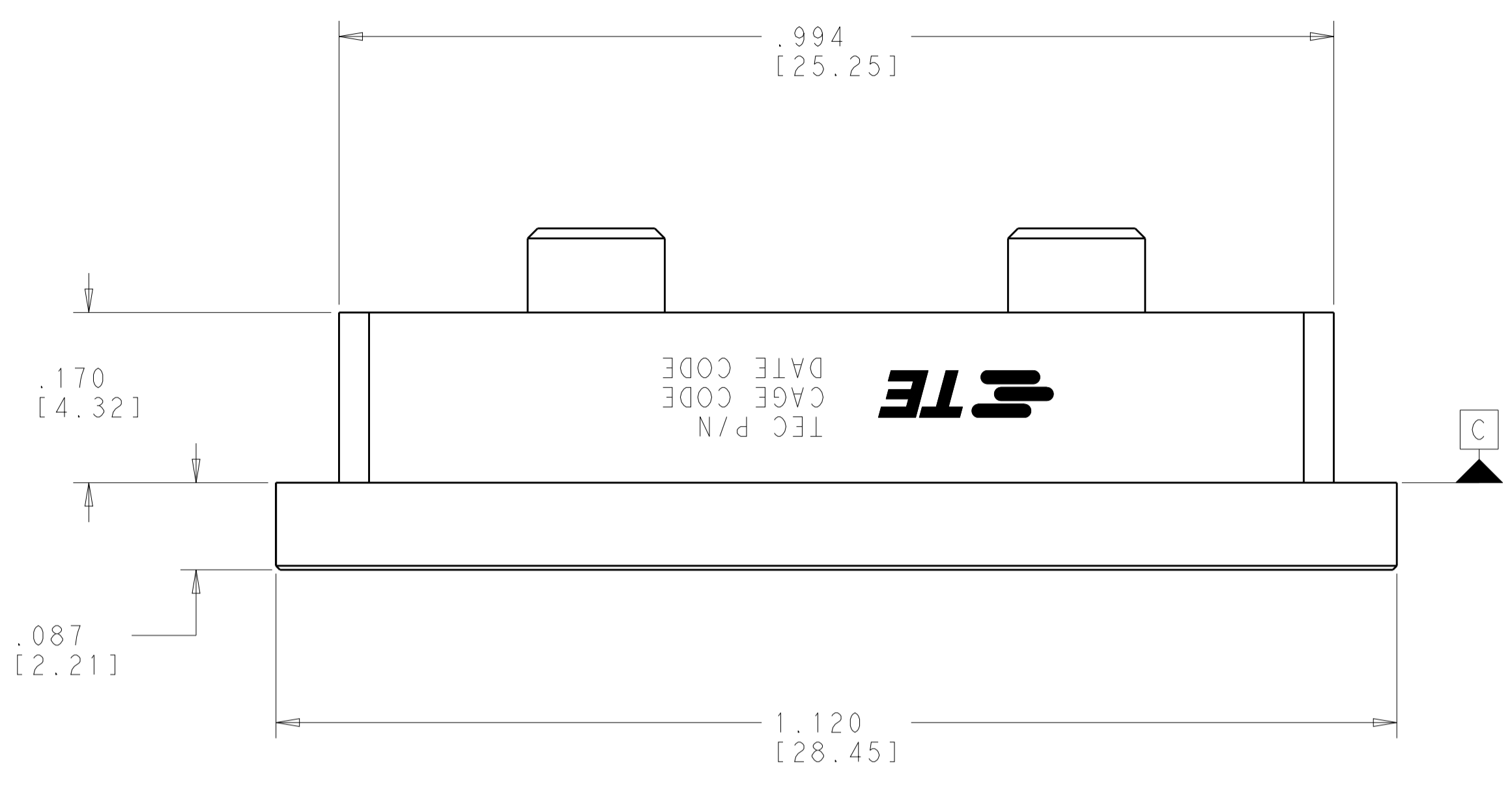
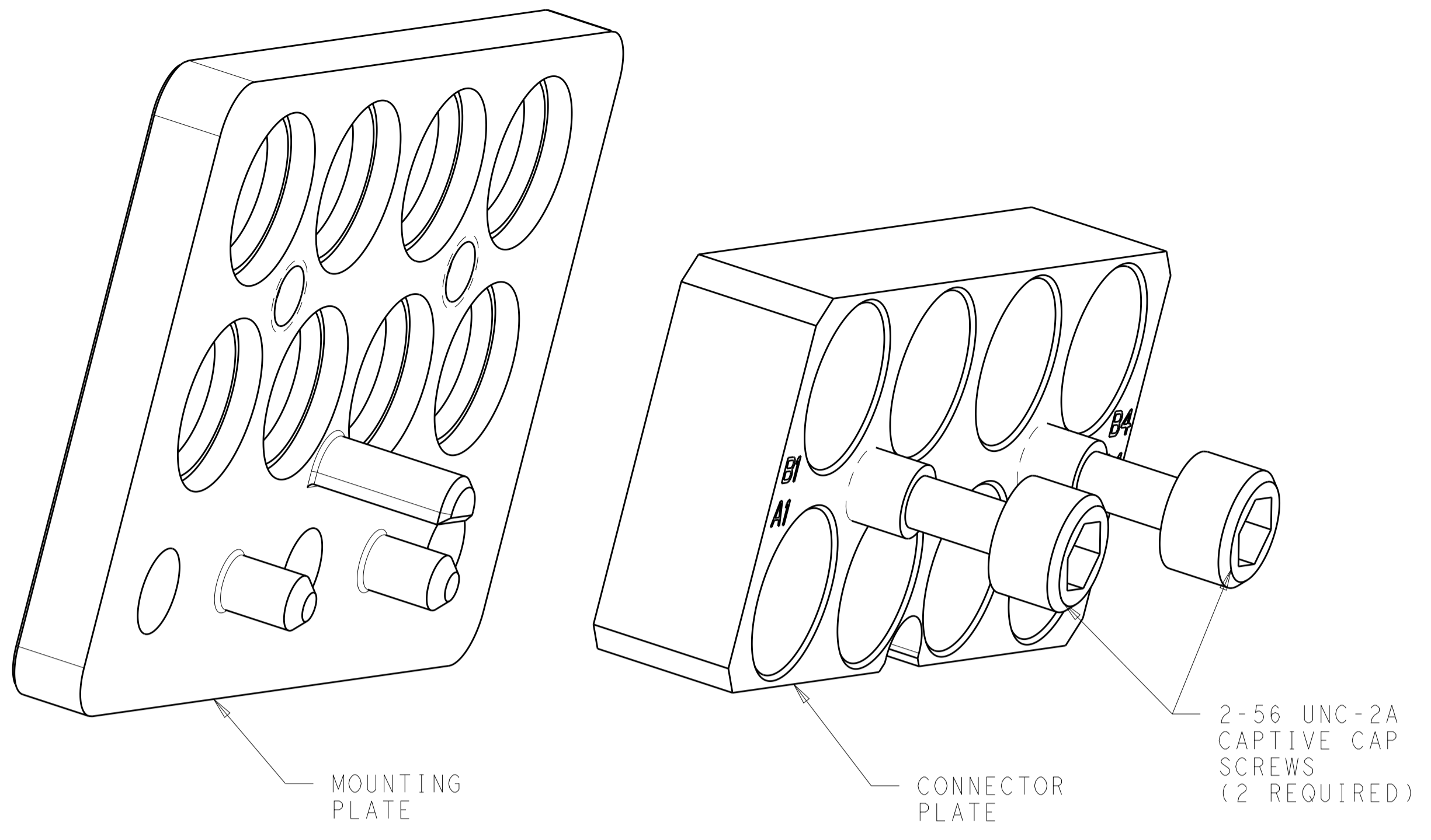

⚠ MATERIAL:
 MOUNTING AND CONNECTOR PLATES - ALUMINUM ALLOY 6061-T6, PER ASTM B 221
 CAPTIVE CAP SCREWS - STAINLESS STEEL TYPE 18.8

⚠ FINISH:
 MOUNTING AND CONNECTOR PLATES - CLEAR TRIVALENT CHROMATE
 CONVERSION COATING PER MIL-DTL-5541F, CLASS 1A, TYPE II
 CAPTIVE CAP SCREWS - PASSIVATED

2157553-1
 PART NUMBER

THIS DRAWING IS A CONTROLLED DOCUMENT. DIMENSIONING AND TOLERANCING PER ASME Y14.5M-2009.		DWN: RJM3 25APR2011	TE Connectivity NAME: 8 POSITION RF BACKPLANE MODULE FOR REMOVABLE CONTACTS
DIMENSIONS: [INCHES][mm]		CHK: S.T. Morley 25APR2011	
TOLERANCES UNLESS OTHERWISE SPECIFIED:		APVD: S.T. Morley 25APR2011	PRODUCT SPEC
0 PLC ±.1			APPLICATION SPEC
1 PLC ±.01			
2 PLC ±.002			
3 PLC ±.0005			
4 PLC ±.0005			
ANGLES ±.005			
FINISH		WEIGHT	RESTRICTED TO
MATERIAL		Customer Drawing	SCALE: 8:1 SHEET 1 OF 1 REV A