

機能満載、負圧（真空圧）及び正圧を同一形状で標準化

圧カスイッチ PRESSURE SWITCHES

PS40

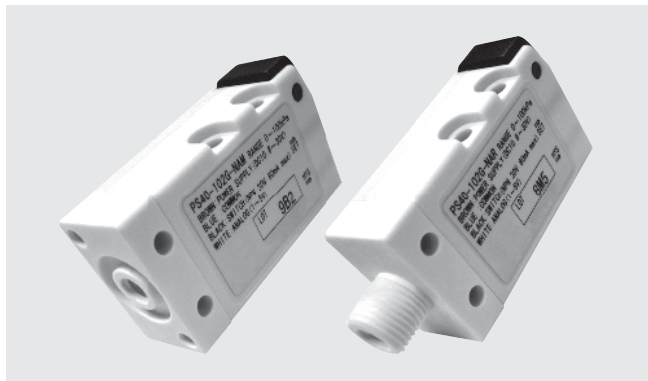

内部構造図 (M5 メネジ)
INTERNAL STRUCTURE (M5 female screw)

名称 Part name	材料 Material
① 圧カポート Pressure port	POM (Polyoxymethylene)
② ハウジング Housing	PC (Polycarbonate)
③ Oリング "O" ring	フッ素ゴム Fluoro-rubber
④ ポートブロック Port block	LCP (Liquid crystal polymer)

■特長 FEATURES

- 非腐食性気体用
- 可動部分を持たない電子式圧カスイッチ
- 2タイプの圧カポート形状
- 2タイプのスイッチ出力機能
- 2タイプのスイッチ出力方式
- アナログ出力タイプも有り
- Compatible with non-corrosive gases
- Solidstate pressure switch with no mechanical moving parts
- 2 types of pressure ports are available
- Open collector output of either NPN or PNP is available
- Analog output type available

■型式表示 MODEL NUMBER DESIGNATION

P S 4 0 - 1 0 2 G - N A R

<p>シリーズ名 Series name</p> <p>定格圧力 Rated pressure range</p> <p>501 : 0 ~ 50 kPa 102 : 0 ~ 100 kPa 103 : 0 ~ 1000 kPa</p> <p>指示方式 Pressure reference</p> <p>G : ゲージ圧 Gauge V : ゲージ圧 (真空圧) Gauge (Vacuum)</p>	<p>圧カポート形状 Pressure port</p> <p>R : R 1/8 オネジ R 1/8 male screw M : M 5 メネジ M 5 female screw</p> <p>スイッチ出力形態 Outputs</p> <p>A : SW出力1点 (応差可変) + アナログ出力 1 switch output with adjustable hysteresis and analog output W : SW出力2点 2 switch output</p> <p>スイッチ出力方式 Switch output interface</p> <p>N : NPN 出力 NPN open collector P : PNP 出力 PNP open collector</p>
---	--

■型式一覧表 LIST OF MODEL NUMBERS

圧カポート Pressure port	スイッチ出力形態 Outputs	スイッチ出力方式 Switch output	102V	501G	102G	103G
			-100 kPa	50 kPa	100 kPa	1000 kPa
R 1/8 オネジ R 1/8 male screw	応差可変スイッチ出力 + アナログ出力 Adjustable hysteresis switch output + Analog output	NPN open collector output	PS40-102V-NAR	PS40-501G-NAR	PS40-102G-NAR	PS40-103G-NAR
		PNP open collector output	PS40-102V-PAR		PS40-102G-PAR	PS40-103G-PAR
	スイッチ出力 (2点) 2 points switch output	NPN open collector output	PS40-102V-NWR	PS40-501G-NWR	PS40-102G-NWR	PS40-103G-NWR
		PNP open collector output	PS40-102V-PWR		PS40-102G-PWR	PS40-103G-PWR
M 5 メネジ M 5 female screw	応差可変スイッチ出力 + アナログ出力 Adjustable hysteresis switch output + Analog output	NPN open collector output	PS40-102V-NAM	PS40-501G-NAM	PS40-102G-NAM	PS40-103G-NAM
		PNP open collector output	PS40-102V-PAM		PS40-102G-PAM	PS40-103G-PAM
	スイッチ出力 (2点) 2 points switch output	NPN open collector output	PS40-102V-NWM	PS40-501G-NWM	PS40-102G-NWM	PS40-103G-NWM
		PNP open collector output	PS40-102V-PWM		PS40-102G-PWM	PS40-103G-PWM

☐ : 製作不可能

※ご注文に際しては、上記型式をご確認ください。

☐ : Not available

※ Verify the above model numbers when placing orders.

PS40

PRESSURE SWITCHES

■標準仕様 STANDARD SPECIFICATIONS

- 特記ない場合、周囲温度 25 ± 5 °C、駆動電圧 12 V DC で規定します。
Unless otherwise specified, the specs are defined at an ambient temperature of 25±5 °C and excitation voltage of 12 V DC.

項目 Item		型式 Model number	102V	501G	102G	103G
一般仕様 General specifications	形 (指示方式) Pressure reference		ゲージ圧 Gauge			
	定格圧力 Rated pressure range	kPa	- 100	50	100	1000
	最大圧力 Maximum pressure	kPa	200	100	200	1500
	破壊圧力 Break-down pressure	kPa	500	250	500	2000
	動作温度 Operating temp. range	°C	- 20 ~ 70			
	補償温度 Compensated temp. range	°C	0 ~ 50			
	動作湿度 Operating humidity	%RH	35 ~ 85 (結露ないこと No condensation)			
	保存温度 Storage temp.	°C	- 20 ~ 80			
	適用媒体 Pressure medium		非腐食性気体 Non-corrosive gases			
	絶縁抵抗 Insulation resistance	MΩ minimum	100 (500 V DC)			
	耐電圧 Dielectric strength		500 V AC, 60 s (リーク電流 1 mA 以下 Leakage current 1 mA maximum)			
	圧力ポート Pressure port		R 1/8 (M 5 メネジ付 Female screw) or "O" リング溝 "O" ring groove (M 5 メネジ付 Female screw)			
	質量 Net weight	g	Approx. 50			
	電源 Power	駆動電圧 Supply voltage	V DC	10.8 ~ 30 V (リップル含む Including ripple percentage)		
消費電流 Consumption current		maximum	17 mA (W のみ 25 mA 以下 Only W type 25 mA maximum)			
スイッチ出力 Switch output	出力点数 No. of outputs		1 or 2			
	出力方式 Output interface		オープンコレクタ (NPN/PNP) Open collector output (NPN or PNP)			
	設定方式 Setting method		トリマによる可変式 Adjustable by VR			
	設定範囲 Adjustable range		定格圧力範囲以上 Zero through rated pressure minimum			
	出力表示 Display		赤色 LED 点灯 (W タイプ : SW1 赤色、SW2 緑色) Red LED ON (W type only : SW1 Red, SW2 Green)			
	精度 0 ~ 50 °C (基準温度 25 °C) Accuracy (Reference temp.: 25 °C)	% F.S.	± 3			
	応差 Hysteresis		設定値の約 1 ~ 15 % (W タイプは固定 2 % F.S. 以下) Approx. 1 ~ 15 % of the set value (W type only 2 % F.S. maximum)			
	スイッチ容量 Switching capacity		30 V 80 mA			
	残留電圧 Residual voltage	V maximum	0.8 (NPN), 1.2 (PNP)			
	応答速度 Response	ms	Approx. 1			
アナログ出力 Analog output	出力電圧 Output voltage	V	1 ~ 5			
	ゼロ電圧 Zero voltage	V	1 ± 0.1			
	スパン電圧 Span voltage	V	4 ± 0.1			
	出力電流 Output current	mA maximum	1 (負荷抵抗 5 kΩ 以上 Load resistance 5 kΩ minimum)			

PS40 PRESSURE SWITCHES

■環境特性 ENVIRONMENTAL CHARACTERISTICS

試験項目 Test item	試験方法 (条件 25 ± 5 °C) Test conditions (At 25 ± 5 °C)	変動量 Permissible change
振動 Vibration	10 ~ 500 Hz, 1.5 mm maximum/98.1 m/s ² , 3 directions for 2 hours each	スイッチ出力設定値及びアナログ出力 (ゼロ電圧/スパン電圧) それぞれ最大 ± 2 %F.S. Switch output setting and analog output (Zero voltage/span voltage): ± 2 %F.S. maximum, each
衝撃 Shock	490 m/s ² , 3 directions for 3 times each	
圧力サイクル Pressure cycling	0 ~ 定格圧力 0 ~ Rated pressure, 10 ⁶ cycles	
耐湿性 Moisture resistance	40 °C, 90 ~ 95 %RH, 240 hrs.	

■外形寸法図 OUTLINE DIMENSIONS

Unless otherwise specified, tolerance : ± 0.5(Unit: mm)

● NAR, PAR, NWR, PWR

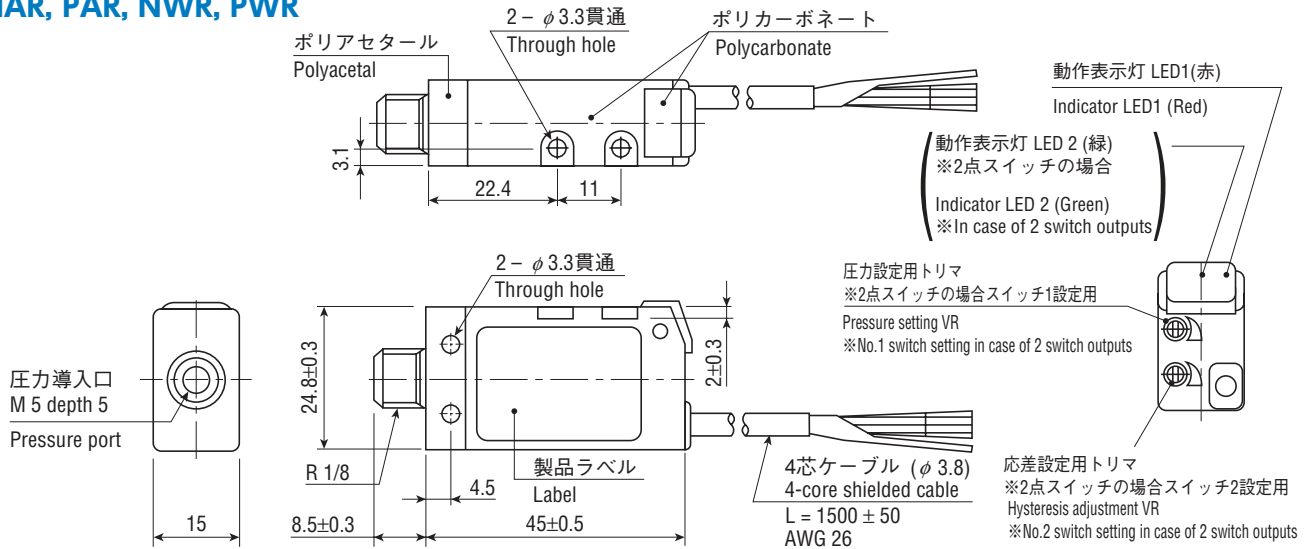

● NAM, PAM, NWM, PWM

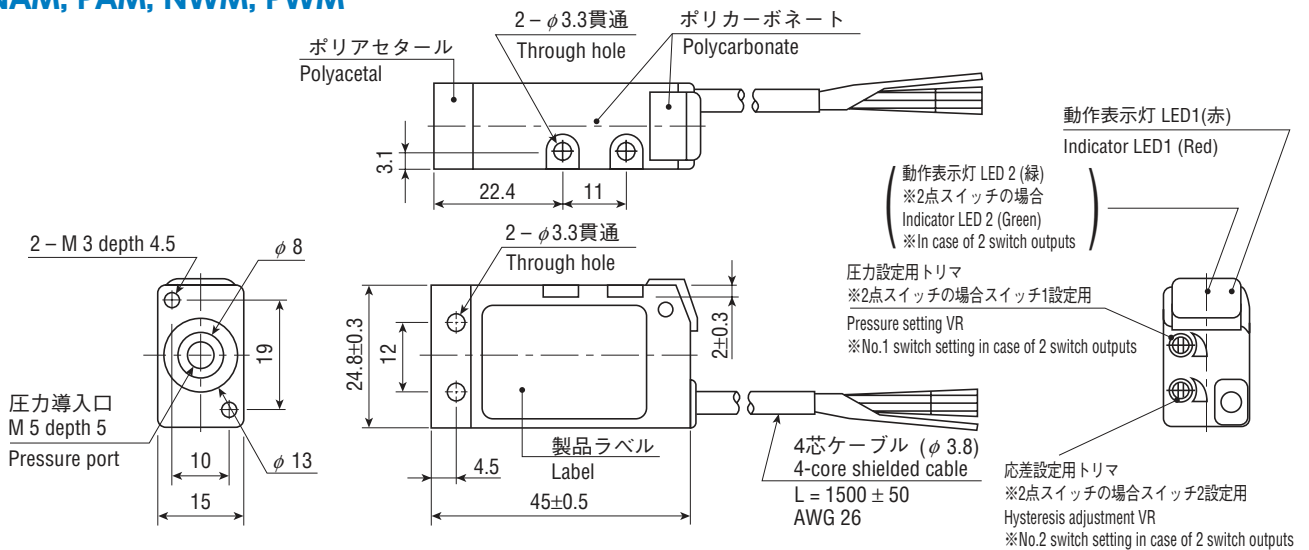

PS40

PRESSURE SWITCHES

PS40 (NAM, NAR, PAM, PAR)

Wire color	Connection
Brown	Power ⊕
Black	Switch output
White	Analog output
Blue	Common
Shield	N.C.

PS40 (NWM, NWR, PWM, PWR)

Wire color	Connection
Brown	Power ⊕
Black	Switch output 1
White	Switch output 2
Blue	Common
Shield	N.C.

内部電気回路 INTERNAL ELECTRICAL SCHEMATICS

● NAM, NAR (NPN/ 応差可変スイッチ)

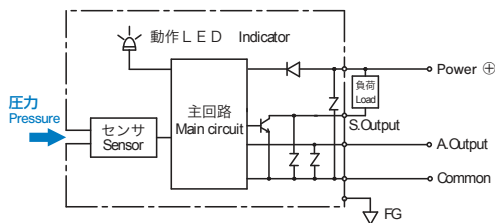

● PAM, PAR (PNP/ 応差可変スイッチ)

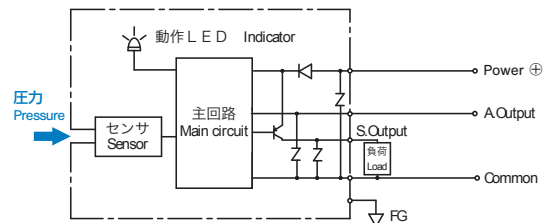

● NWM, NWR (NPN/2点スイッチ)

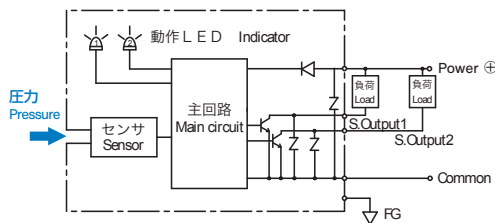

● PWM, PWR (PNP/2点スイッチ)

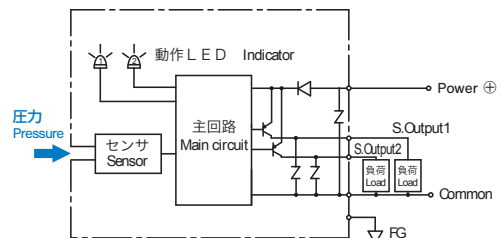

スイッチ出力動作 SWITCH OUTPUT SCHEMATICS

● PS40-102V

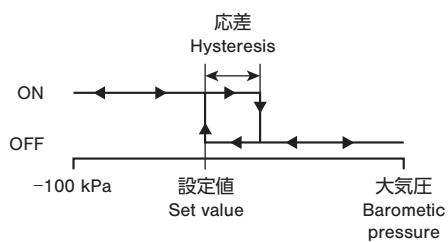

● PS40-***G

