

TH series

Proportional single axis throttle controllers •
non-contacting Hall effect technology



DISTINCTIVE FEATURES

Friction hold

Single or redundant outputs



ENVIRONMENTAL SPECIFICATIONS

- Operating Temperature: -25 °C to +70 °C (-13 °F to +158 °F)
- Storage Temperature: -40 °C to +70 °C (-40 °F to +158 °F)
- Above Panel Sealing: Up to IP63 (subject to handle configuration)
- EMC Immunity Level: EN61000-4-3: 2006
- EMC Emissions Level: EN61000-4-8: 2009
- ESD: EN61000-4-2: 2008



ELECTRICAL SPECIFICATIONS

- Supply Voltage range: 5.00 VDC \pm 0.01 VDC
- Reverse Polarity Max: -14.5 VDC
- Ratiometric Output Voltage: See options
- Transient Overvoltage max: 18 V
- Output Impedance: 6 Ω
- Return to Center Voltage Tolerance: \pm 200 mV initial
- Current Consumption Max: 10 mA



MECHANICAL SPECIFICATIONS

- Operating Force: 7.7 N (1.70 lbf)
- Break Out Force: 6.6 N (1.50 lbf)
- Mechanical Angle of Movement: 70°
- Expected Life: 10 million lifecycles
- Mass /weight: Varies
- Lever Action (centering): Friction

The company reserves the right to change specifications without notice.



TH series

Single axis throttle controllers •
non-contacting Hall effect technology



MATERIALS

- Body: Glass Filled Nylon
- Handles: Glass Filled Nylon



ELECTRICAL MICROSWITCH

- Electrical rating: 0.1A at 30VDC (resistive load)
- Insulation resistance: 100 MΩ min (at 500VDC)
- Contact resistance: 100 MΩ max
- Dielectric strength: 600VAC, 50/60 Hz for 1 min between terminals of the same polarity; 1,000VAC, 50/60 Hz for 1 min between current-carrying metal parts and ground and between each terminal and non current-carrying metal parts
- Vibration resistance: Malfunction 10 to 55Hz, 1.5mm double amplitude
- Shock resistance: Destruction 1,000 m/s² (approx. 100G) max
Malfunction 200 m/s² (approx. 20G) max
- Durability: Mechanical 1,000,000 operations min. (60 operations/min)
Electrical 100,000 operations min. (30 operations/min)



DROP-IN MOUNTING CUT-OUT DIMENSIONS

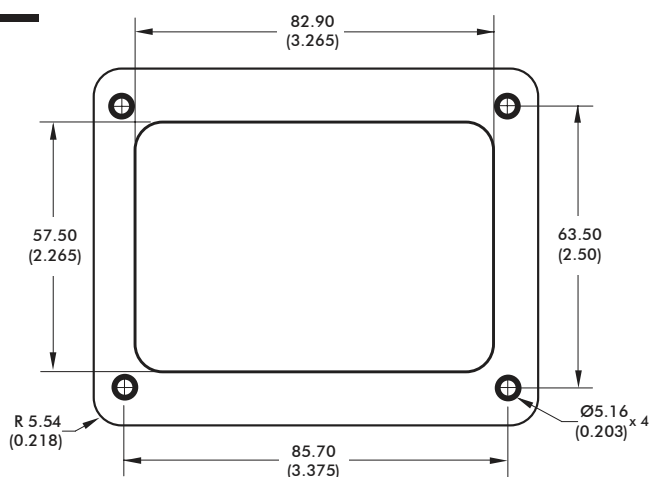

REAR MOUNT CUT-OUT DIMENSIONS

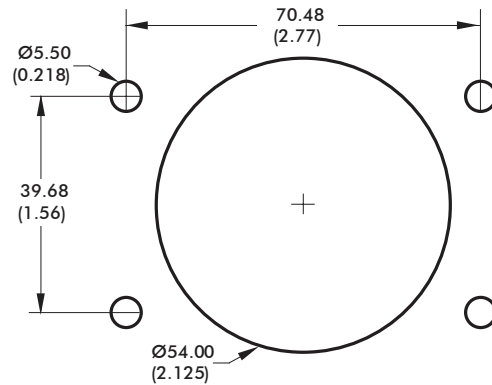

* Operating force: configuration option «L»

TH series

Single axis throttle controllers • non-contacting Hall effect technology



BUILD YOUR PART NUMBER

<div style="border: 1px solid black; padding: 2px; width: 40px; margin: 0 auto;">TH</div> <p>.....</p> <p>SERIES</p> <table border="0"> <tr><td style="border: 1px solid black; padding: 2px;">0</td><td>Ball Tip</td></tr> <tr><td style="border: 1px solid black; padding: 2px;">1</td><td>Stock Grip</td></tr> <tr><td style="border: 1px solid black; padding: 2px;">2</td><td>Short Stock Grip</td></tr> <tr><td style="border: 1px solid black; padding: 2px;">5</td><td>Palm Grip²</td></tr> </table>	0	Ball Tip	1	Stock Grip	2	Short Stock Grip	5	Palm Grip ²	<div style="border: 1px solid black; padding: 2px; width: 40px; margin: 0 auto;"> </div> <p>.....</p> <p>HANDLE¹</p>	<div style="border: 1px solid black; padding: 2px; width: 40px; margin: 0 auto;"> </div> <p>.....</p> <p>FRONT BUTTONS</p> <table border="0"> <tr><td style="border: 1px solid black; padding: 2px;">0</td><td>None</td></tr> <tr><td style="border: 1px solid black; padding: 2px;">1</td><td>One</td></tr> </table>	0	None	1	One	<div style="border: 1px solid black; padding: 2px; width: 40px; margin: 0 auto;"> </div> <p>.....</p> <p>TOP BUTTONS</p> <table border="0"> <tr><td style="border: 1px solid black; padding: 2px;">0</td><td>None</td></tr> <tr><td style="border: 1px solid black; padding: 2px;">1</td><td>One</td></tr> <tr><td style="border: 1px solid black; padding: 2px;">2</td><td>Two</td></tr> </table>	0	None	1	One	2	Two	<div style="border: 1px solid black; padding: 2px; width: 40px; margin: 0 auto;"> </div> <p>.....</p> <p>SIDE BUTTONS</p> <table border="0"> <tr><td style="border: 1px solid black; padding: 2px;">0</td><td>None</td></tr> <tr><td style="border: 1px solid black; padding: 2px;">U</td><td>One - upper position</td></tr> <tr><td style="border: 1px solid black; padding: 2px;">L</td><td>One - lower position</td></tr> <tr><td style="border: 1px solid black; padding: 2px;">T</td><td>Two</td></tr> <tr><td style="border: 1px solid black; padding: 2px;">D</td><td>Operator presence paddle</td></tr> <tr><td style="border: 1px solid black; padding: 2px;">P</td><td>Palm Grip (with 3 side buttons)</td></tr> </table>	0	None	U	One - upper position	L	One - lower position	T	Two	D	Operator presence paddle	P	Palm Grip (with 3 side buttons)	<div style="border: 1px solid black; padding: 2px; width: 40px; margin: 0 auto;"> </div> <p>.....</p> <p>MICROSWITCHES</p> <table border="0"> <tr><td style="border: 1px solid black; padding: 2px;">0</td><td>None</td></tr> <tr><td style="border: 1px solid black; padding: 2px;">1</td><td>-35°</td></tr> <tr><td style="border: 1px solid black; padding: 2px;">2</td><td>0°</td></tr> <tr><td style="border: 1px solid black; padding: 2px;">3</td><td>+35°</td></tr> <tr><td style="border: 1px solid black; padding: 2px;">4</td><td>-35° and 0°</td></tr> <tr><td style="border: 1px solid black; padding: 2px;">5</td><td>-35° and +35°</td></tr> <tr><td style="border: 1px solid black; padding: 2px;">6</td><td>0° and +35°</td></tr> <tr><td style="border: 1px solid black; padding: 2px;">7</td><td>-35°, 0 and +35°</td></tr> </table>	0	None	1	-35°	2	0°	3	+35°	4	-35° and 0°	5	-35° and +35°	6	0° and +35°	7	-35°, 0 and +35°
0	Ball Tip																																																		
1	Stock Grip																																																		
2	Short Stock Grip																																																		
5	Palm Grip ²																																																		
0	None																																																		
1	One																																																		
0	None																																																		
1	One																																																		
2	Two																																																		
0	None																																																		
U	One - upper position																																																		
L	One - lower position																																																		
T	Two																																																		
D	Operator presence paddle																																																		
P	Palm Grip (with 3 side buttons)																																																		
0	None																																																		
1	-35°																																																		
2	0°																																																		
3	+35°																																																		
4	-35° and 0°																																																		
5	-35° and +35°																																																		
6	0° and +35°																																																		
7	-35°, 0 and +35°																																																		
<div style="border: 1px solid black; padding: 2px; width: 40px; margin: 0 auto;"> </div> <p>.....</p> <p>MECHANICAL DETENTS</p> <table border="0"> <tr><td style="border: 1px solid black; padding: 2px;">0</td><td>None</td></tr> <tr><td style="border: 1px solid black; padding: 2px;">1</td><td>-35°</td></tr> <tr><td style="border: 1px solid black; padding: 2px;">2</td><td>0°</td></tr> <tr><td style="border: 1px solid black; padding: 2px;">3</td><td>+35°</td></tr> <tr><td style="border: 1px solid black; padding: 2px;">4</td><td>-35° and 0°</td></tr> <tr><td style="border: 1px solid black; padding: 2px;">5</td><td>-35° and +35°</td></tr> <tr><td style="border: 1px solid black; padding: 2px;">6</td><td>0° and +35°</td></tr> <tr><td style="border: 1px solid black; padding: 2px;">7</td><td>-35°, 0 and +35°</td></tr> </table>	0	None	1	-35°	2	0°	3	+35°	4	-35° and 0°	5	-35° and +35°	6	0° and +35°	7	-35°, 0 and +35°	<div style="border: 1px solid black; padding: 2px; width: 40px; margin: 0 auto;"> </div> <p>.....</p> <p>MOUNTING OPTIONS</p> <table border="0"> <tr><td style="border: 1px solid black; padding: 2px;">R</td><td>Rear mount</td></tr> <tr><td style="border: 1px solid black; padding: 2px;">D</td><td>Drop-in</td></tr> </table>	R	Rear mount	D	Drop-in	<div style="border: 1px solid black; padding: 2px; width: 40px; margin: 0 auto;"> </div> <p>.....</p> <p>OUTPUT OPTIONS</p> <table border="0"> <tr><td style="border: 1px solid black; padding: 2px;">0</td><td>0V to 5V</td></tr> <tr><td style="border: 1px solid black; padding: 2px;">1</td><td>0.5V to 4.5V</td></tr> <tr><td style="border: 1px solid black; padding: 2px;">2</td><td>0.25V to 4.75V</td></tr> <tr><td style="border: 1px solid black; padding: 2px;">3</td><td>0V to 5V Sensor 1 0V to 5V Sensor 2</td></tr> <tr><td style="border: 1px solid black; padding: 2px;">4</td><td>0.5V to 4.5V Sensor 1 0.5V to 4.5V Sensor 2</td></tr> </table>	0	0V to 5V	1	0.5V to 4.5V	2	0.25V to 4.75V	3	0V to 5V Sensor 1 0V to 5V Sensor 2	4	0.5V to 4.5V Sensor 1 0.5V to 4.5V Sensor 2	<div style="border: 1px solid black; padding: 2px; width: 40px; margin: 0 auto;"> </div> <p>.....</p> <p>ADDITIONAL OPTIONS</p> <table border="0"> <tr><td style="border: 1px solid black; padding: 2px;">5</td><td>0.25V to 4.75V Sensor 1 0.25V to 4.75V Sensor 2</td></tr> <tr><td style="border: 1px solid black; padding: 2px;">6</td><td>0V to 5V Sensor 1 5V to 0V Sensor 2</td></tr> <tr><td style="border: 1px solid black; padding: 2px;">7</td><td>0.5V to 4.5V Sensor 1 4.5V to 0.5V Sensor 2</td></tr> <tr><td style="border: 1px solid black; padding: 2px;">8</td><td>0.25V to 4.75V Sensor 1 4.75V to 0.25V Sensor 2</td></tr> </table>	5	0.25V to 4.75V Sensor 1 0.25V to 4.75V Sensor 2	6	0V to 5V Sensor 1 5V to 0V Sensor 2	7	0.5V to 4.5V Sensor 1 4.5V to 0.5V Sensor 2	8	0.25V to 4.75V Sensor 1 4.75V to 0.25V Sensor 2	<div style="border: 1px solid black; padding: 2px; width: 40px; margin: 0 auto;"> </div> <p>.....</p> <p>ADDITIONAL OPTIONS</p> <table border="0"> <tr><td style="border: 1px solid black; padding: 2px;">E</td><td>Environmental sealing³</td></tr> </table>	E	Environmental sealing ³							
0	None																																																		
1	-35°																																																		
2	0°																																																		
3	+35°																																																		
4	-35° and 0°																																																		
5	-35° and +35°																																																		
6	0° and +35°																																																		
7	-35°, 0 and +35°																																																		
R	Rear mount																																																		
D	Drop-in																																																		
0	0V to 5V																																																		
1	0.5V to 4.5V																																																		
2	0.25V to 4.75V																																																		
3	0V to 5V Sensor 1 0V to 5V Sensor 2																																																		
4	0.5V to 4.5V Sensor 1 0.5V to 4.5V Sensor 2																																																		
5	0.25V to 4.75V Sensor 1 0.25V to 4.75V Sensor 2																																																		
6	0V to 5V Sensor 1 5V to 0V Sensor 2																																																		
7	0.5V to 4.5V Sensor 1 4.5V to 0.5V Sensor 2																																																		
8	0.25V to 4.75V Sensor 1 4.75V to 0.25V Sensor 2																																																		
E	Environmental sealing ³																																																		

NOTES

- ¹ See information on standard configurations for throttle handles
- ² Palm Grip handle requires drop-in mounting
- ³ Environmental sealing level available up to IP63 and dependant on handle configuration



ABOUT THIS SERIES

Mounting accessories : standard hardware includes: 1 gasket, 4 screws (10-32x3/4 Phillips flat head), 4 washers (#10 split lock), 4 nuts (10-32 hex). The gasket and mounting hardware are shipped off the throttle, in a separate bag.

TH series

Single axis throttle controllers •
non-contacting Hall effect technology

HANDLE 0 - BALL TIP

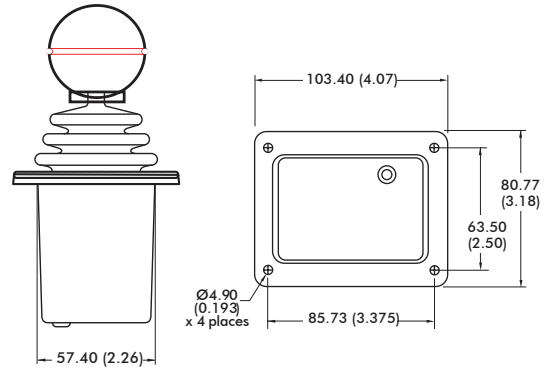
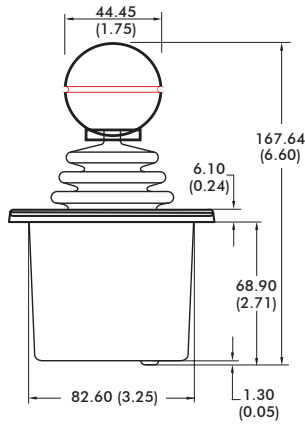

HANDLE 1 - STOCK GRIP

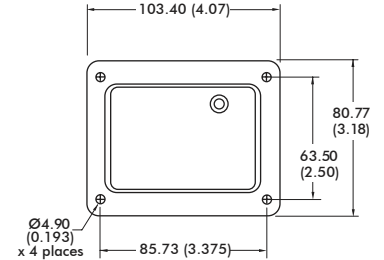

HANDLE 2 - SHORT STOCK GRIP

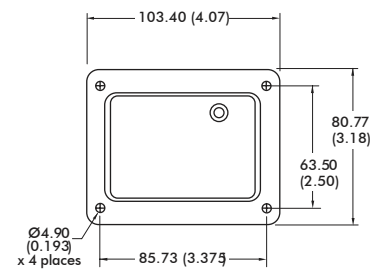

TH series

Single axis throttle controllers • non-contacting Hall effect technology

HANDLE 5 - PALM GRIP

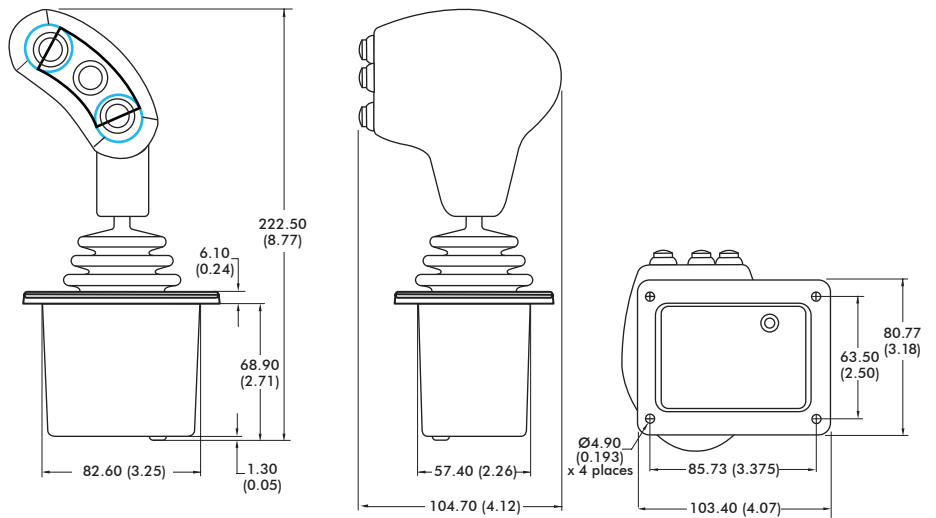

REAR MOUNT

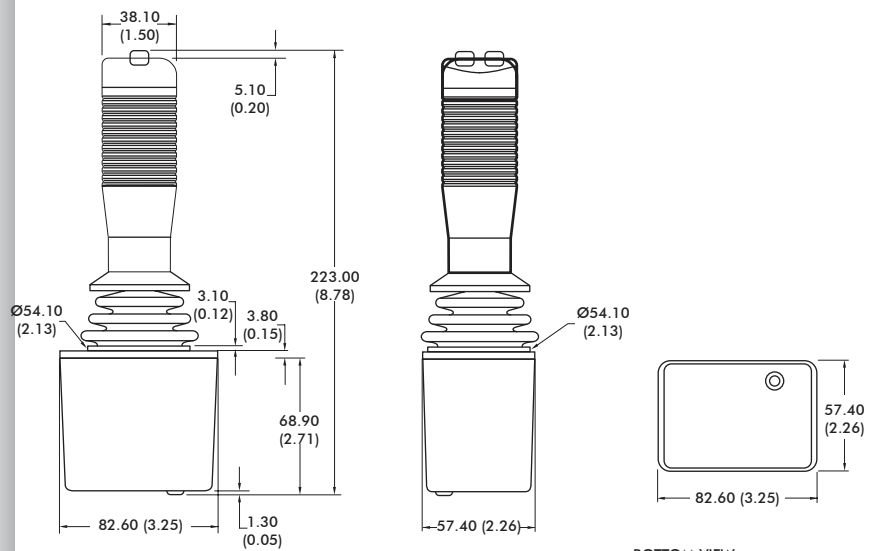

BOTTOM VIEW



HANDLE OPTIONS

STOCK GRIP HANDLE (1)

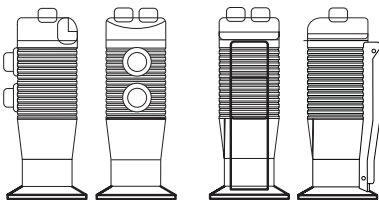

Top & Side Buttons

Operator Presence Paddle

SHORT STOCK GRIP HANDLE (2)

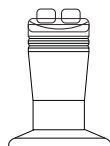

Top Buttons

PALM GRIP HANDLE

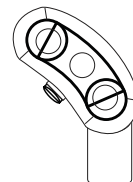

Front Button and Side Buttons

AVAILABLE BUTTON COLORS

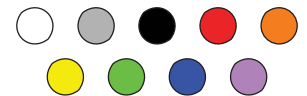

White, Gray, Black, Red (4), Orange, Yellow, Green, Blue, Purple

- 1 The maximum possible configuration for the Stock Grip handle is up to 2 Top Buttons and 2 Side Buttons.
- 2 The maximum possible configuration for the Short Stock Grip handle is up to 2 Top Buttons. Operator Presence Paddle, Index Trigger & Side buttons not available with this handle.
- 3 For non-standard configurations, contact APEM's Product Support Team
- 4 If unspecified, the pushbuttons will have snap action momentary switches with red button caps.