

P	LTR	DESCRIPTION	DATE	DWN	APVD
B		REVISED PER ECO-08-009599	16JUL2008	HMR	CJ
B1		ECO-19-006934	10MAY2019	AP	WS
B2		REVISED PER ECN-22-158558	22JUN2022	WLS	VS

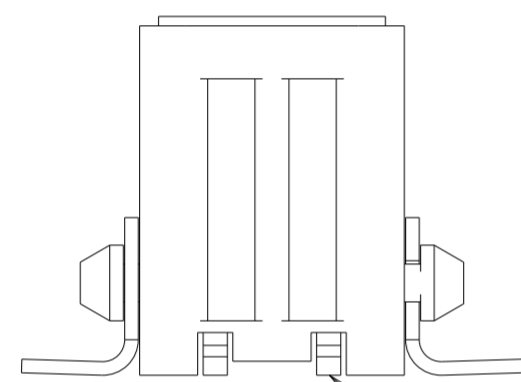
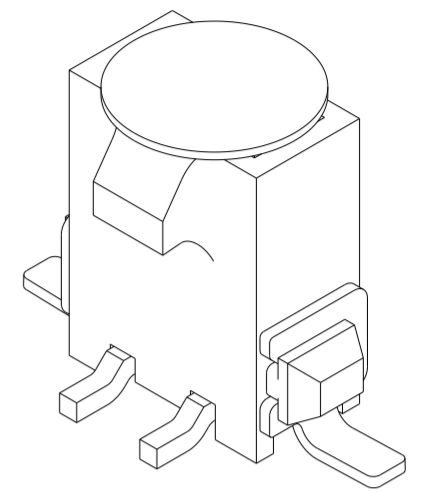
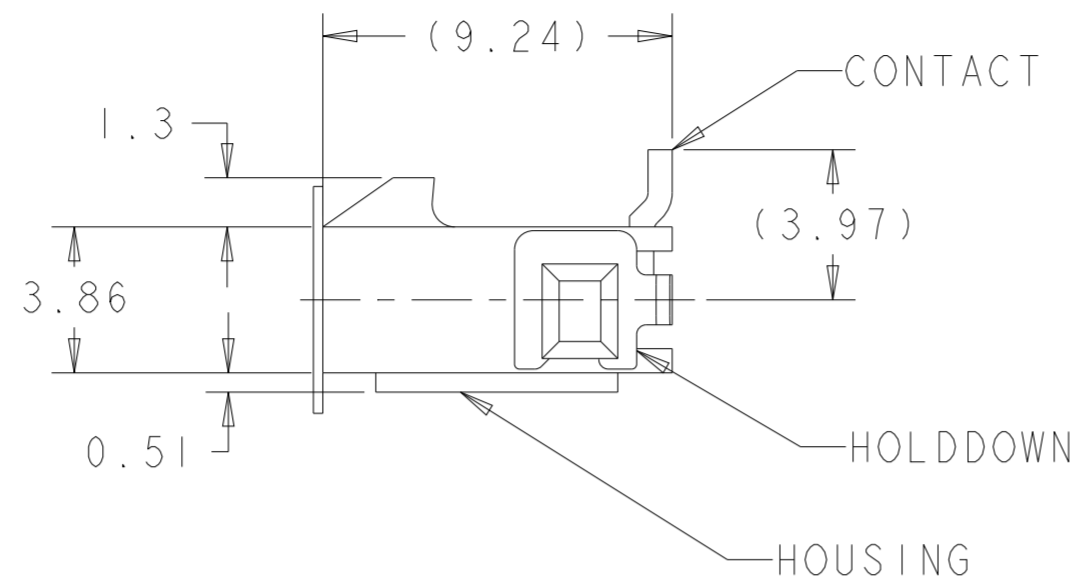
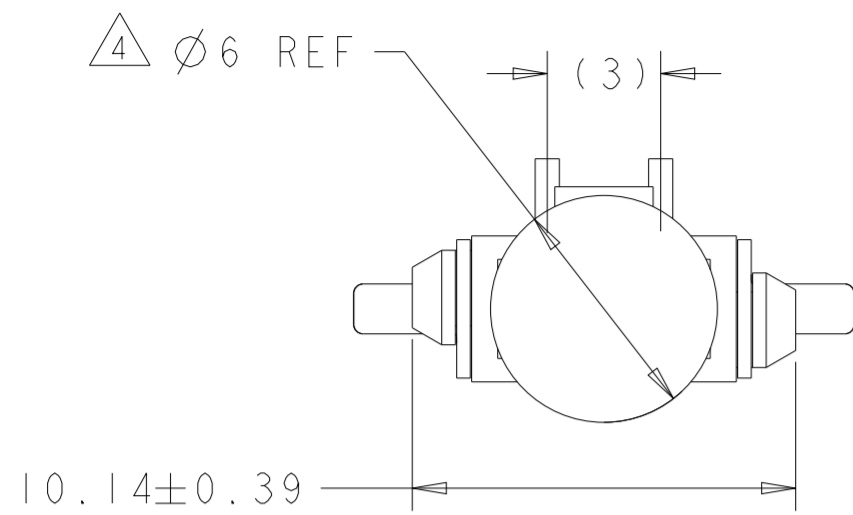

0.15

INCLUDES CONTACT TAILS, HOUSING STANDOFFS, AND BOARDLOCKS

1 MATERIAL: HOUSING - UL 94V-0 RATED HIGH TEMP NYLON, COLOR BLACK.
CONTACTS - BRASS
HOLDDOWNS - PHOSPHOR BRONZE.

2 PLATING: CONTACTS - 0.76 μm MINIMUM GOLD ON MATING AREA,
2.54 μm MINIMUM TIN ON SOLDER TAILS,
ALL OVER 1.27 μm MINIMUM NICKEL.
HOLDDOWNS - 2.54 μm MINIMUM TIN OVER 1.27 μm MINIMUM NICKEL.

3 RECOMMENDED PC BOARD THICKNESS OF 1.57.

4 KAPTON VACUUM PICK UP BUTTON.

- 5 SPECIAL PACKAGING FOR IEC 286-3 REQUIREMENT. PARTS ORIENTED 180° DIFFERENT IN TAPE THAN STANDARD PART NUMBER 1445096.
- 6 COUNTERPART RECOMMENDED IS PN 1445022 OR 2008571 (DASH ACC. TO NUMBER OF POSITION).
- 7 FOR REELING DIRECTION AND PACKAGING TYPE, SEE SPECIFICATION 114-13000.

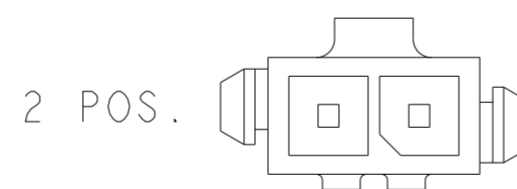
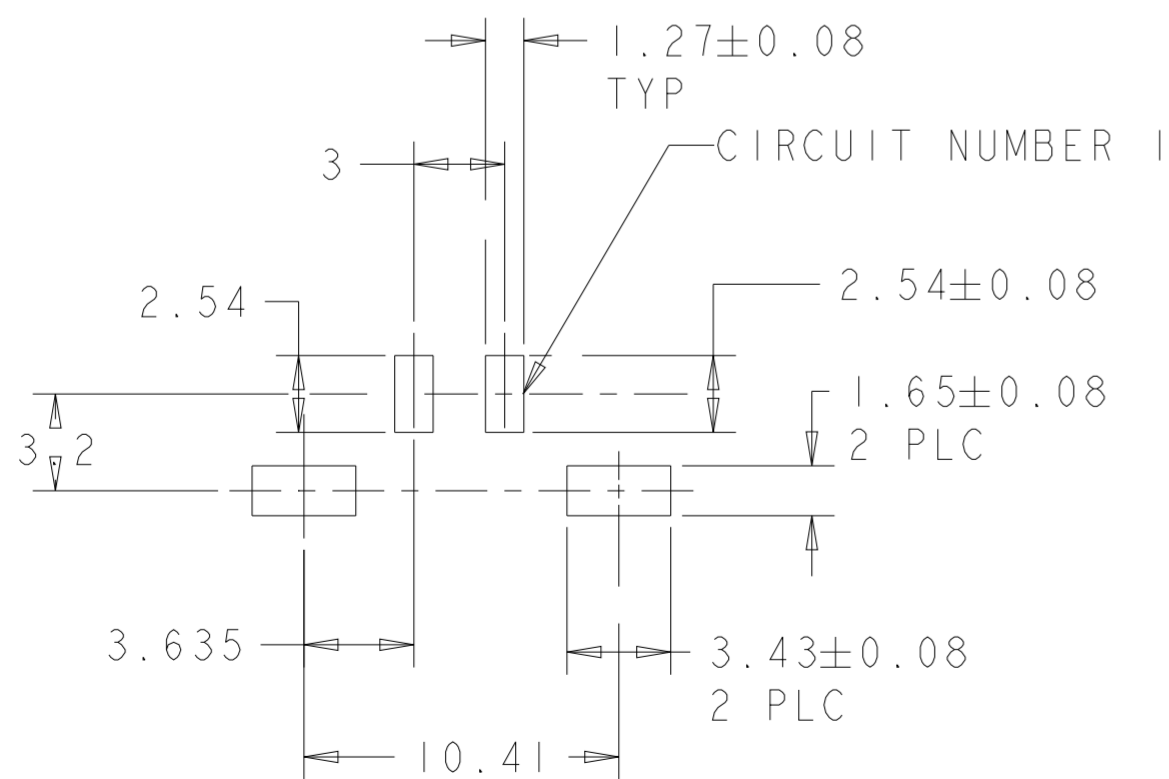

KEYING BY POSITION SIZE

PCB LAYOUT COMPONENT SIDE 3

2	2029032-2
NO. OF POSN	PART NUMBER

THIS DRAWING IS A CONTROLLED DOCUMENT.		DWN K. WHITAKER 15 JAN 2008	TE Connectivity	
DIMENSIONS: mm		CHK C. JONES 15 JAN 2008		
TOLERANCES UNLESS OTHERWISE SPECIFIED:		APVD C. JONES 15 JAN 2008	NAME VERTICAL SURFACE MOUNT HEADER ASSY, 30 MIC GOLD CONTACTS, SURF MOUNT HOLDDOWNS, SGL ROW, MICRO MATE-N-LOK	
0 PLC ± 1 PLC ± 2 PLC ±0.20 3 PLC ± 4 PLC ±		PRODUCT SPEC 108-1836	SIZE A2	
MATERIAL 1		APPLICATION SPEC 114-13000	CAGE CODE 00779	DRAWING NO C-2029032
FINISH 2		WEIGHT -	RESTRICTED TO -	SCALE 4:1
		CUSTOMER DRAWING	SHEET 1	REV B2