Features

- Temperature and Voltage Compensated Frequency
- Warning Indication of Lamp Failure by Means of Frequency Doubling only in Direction Mode
- Voltage Dependence of the Car Indicator Lamps also Compensated for Lamp Failure
- Relay Output with High Current-carrying Capacity and Low Saturation Voltage
- Load-dump Protection
- Minimum Lamp Load for Flasher Operation ≥ 1 W
- Low Susceptibility to EMI
- Extremely Low Standby Current of 10 μ A
- Protection According to ISO/TR 7637/1 Level 4 with External Capacitor (C₂)

Description

The U6432B is an advanced automotive flasher IC which provides low standby current. Its basic function is equal to Atmel's flasher IC U6043B but low current consumption and frequency doubling disabling make outstanding differences.



Low-power Flasher IC with 18-m Ω Shunt

U6432B



Block Diagram

Figure 1. Car Flasher Application

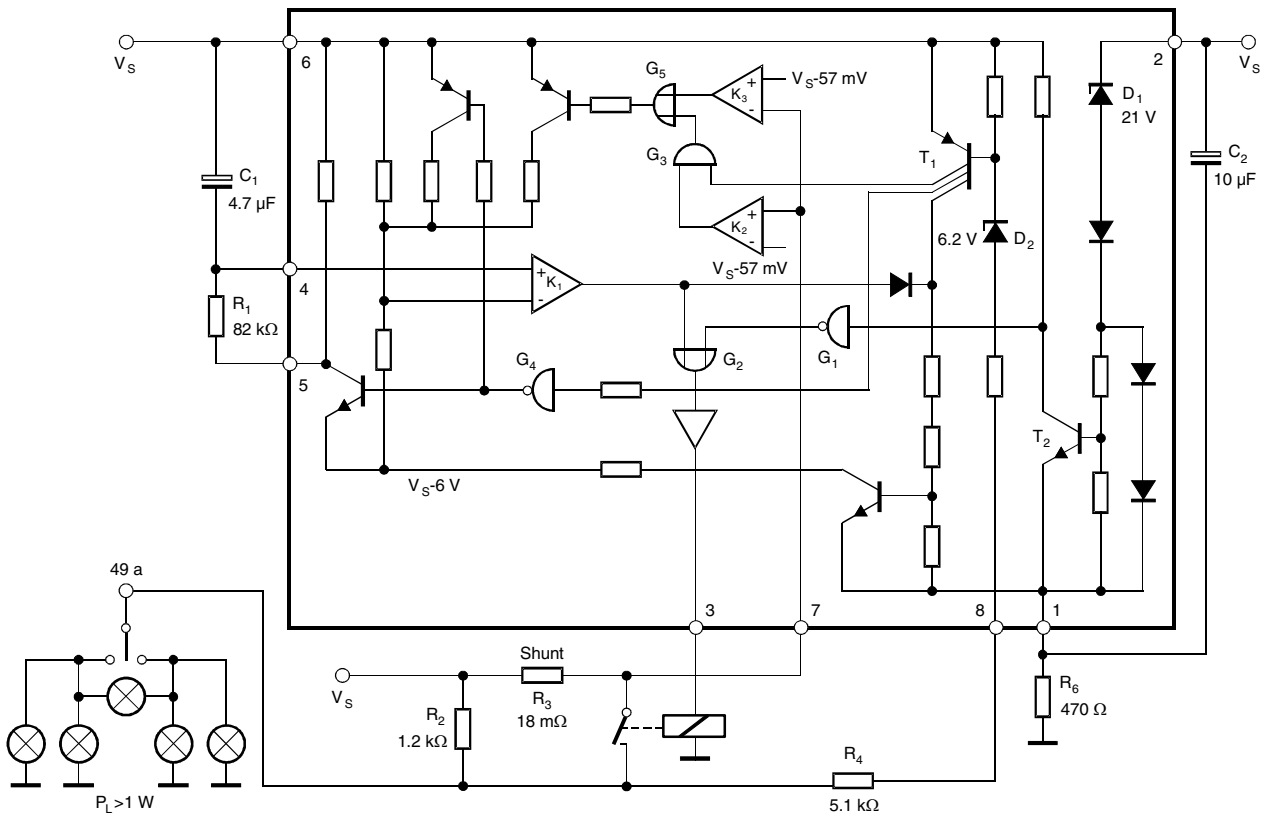

Pin Configuration

Figure 2. Pinning

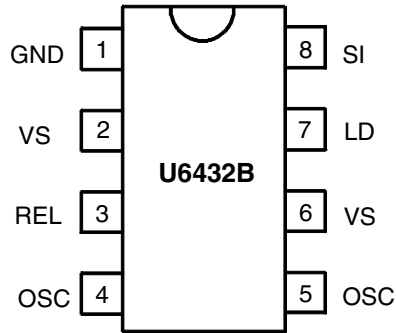

Pin Description

| Pin | Symbol | Function |
|-----|--------|------------------------|
| 1 | GND | IC ground |
| 2 | VS | Supply voltage |
| 3 | REL | Relay driver |
| 4 | OSC | Oscillator |
| 5 | OSC | Oscillator |
| 6 | VS | Supply voltage |
| 7 | LD | Lamp failure detection |
| 8 | SI | Start input (49a) |

Functional Description

Pin 1, GND

The U6432B is protected against damage in case of battery reversal via resistor R_4 to ground (-31). An integrated protection circuit together with external resistances R_2 and R_4 limits the current pulses in the IC.

Pin 2, Supply Voltage, V_S power

The arrangement of the supply connections to Pin 2 (and 6) must be so as to ensure that on the connection printed circuit board (PCB), the resistance of V_S to Pin 6 is lower than that to Pin 2.

Pin 3, Relay Control Output (Driver)

The relay control output is a high-side driver with a low saturation voltage. It is capable of driving a typical automotive relay with a minimum coil resistance of 60 Ω .

Pin 4 and 5, Oscillator

The flashing frequency, f_1 , is determined by the R_1C_1 components as given by the formula below (see Figure 1):

$$f_1 \approx \frac{1}{R_1 \times C_1 \times 1.5} \text{ Hz}$$

where $C_1 \leq 47 \mu\text{F}$, $R_1 = 6.8 \text{ k}\Omega$ to 510 $\text{k}\Omega$

In case of a lamp outage (see Pin 7) the oscillator frequency is switched to the lamp outage frequency f_2 with $f_2 \approx 2.2 \times f_1$.

Duty cycle in normal flashing mode: 50%

Duty cycle in lamp outage mode: 40% (bright phase)

Pin 6, Supply Voltage, Sense

For accurate monitoring via the shunt resistor, a minimized layer resistance from point V_S /shunt to Pin 6 is recommended.

Pin 7

Control Signal Threshold (49 mV Comparator)

The detection point for lamp failure can be calculated from the control signal threshold, typically 49 mV with $V_S = 12 \text{ V}$. With a measuring resistance of $R_3 = 18 \text{ m}\Omega$, the frequency change-over is reached at a lamp load of 21 W + 11.4 W. The variation of the control signal threshold supply voltage takes into account the PTC characteristic of filament lamps.

Control Signal Threshold 2 (15-mV Comparator)

A voltage drop at the shunt resistor R_3 between 49 mV and 15 mV lets the flasher work in frequency doubling mode.

If the voltage drop decreases to a value below $V_{R3\text{MAX}} = 15 \text{ mV}$, frequency doubling is disabled.

This can be achieved either with a switch which by-passes the shunt resistor (e.g., a special hazard warning switch) or with a small lamp load.

Flasher operation starts with a lamp load of $P_L \geq 1 \text{ W}$.

Pin 8, Start Input

Start condition for flashing:

- Voltage at Pin 8 (see Figure 1)
- $V_8 \leq V_S - (V_{BE(T1)} + V_{Z(D2)})$

Condition for standby:

The resistor R_2 between V_S and Pin 8 provides an extremely low standby current ($I_S \leq 10 \mu A$). The leakage current depends on the pull-up resistor R_2 according to the following formula:

$$I_{Leak} \approx (V_{BE(T1)} + V_{Z(D2)})/R_2$$

Application Hint

In order to achieve a high-level immunity against "electrical interference by conduction and coupling" according to ISO/TR 7637/1 test level 4, an electrolytic capacitor $C_2 = 10 \mu F$ (25 V) between Pin 1 and 2 – mounted close to the IC – is highly recommended.

Absolute Maximum Ratings

Reference point Pin 1

| Parameters | | Symbol | Value | Unit |
|------------------------------|-------------|-----------|-------------|------------|
| Supply voltage | Pin 2 and 6 | V_S | 18 | V |
| Surge Forward Current | | | | |
| $t_p = 0.1 \text{ ms}$ | Pin 2 and 6 | I_{FSM} | 1.5 | A |
| $t_p = 300 \text{ ms}$ | Pin 2 and 6 | I_{FSM} | 1.0 | A |
| $t_p = 300 \text{ ms}$ | Pin 8 | I_{FSM} | 30 | mA |
| Output current | Pin 3 | I_O | 0.3 | A |
| Power Dissipation | | | | |
| $T_{amb} = 95^\circ C$ | DIP 8 | P_{tot} | 420 | mW |
| | SO8 | P_{tot} | 340 | mW |
| $T_{amb} = 60^\circ C$ | DIP 8 | P_{tot} | 690 | mW |
| | SO8 | P_{tot} | 560 | mW |
| Junction temperature | | T_J | 150 | $^\circ C$ |
| Ambient temperature range | | T_{amb} | -40 to +105 | $^\circ C$ |
| Storage temperature range | | T_{stg} | -55 to +150 | $^\circ C$ |

Electrical Characteristics

$T_{amb} = 25^{\circ}\text{C}$; typical values under normal operation in application circuit Figure 1, $V_S = 12\text{ V}$ (Pins 2 and 6); reference point ground (-31), unless otherwise specified.

| Parameters | Test Conditions | Symbol | Min. | Typ. | Max. | Unit |
|----------------------------------|----------------------------------------------------------------------------------------------------------------|--------------|-------------------|----------------|------------------|---------------|
| Supply voltage range | Pin 2 and 6 | V_S | 9 | | 16.5 | V |
| Supply current, dark phase | Pins 2 and 6 | I_S | | 4.5 | 8 | mA |
| Supply current, stand-by | Pins 2 and 6 | I_S | | | 10 | mA |
| Supply current, bright phase | Pins 2 and 6 | I_S | | 7.0 | 11 | mA |
| Relay output, saturation voltage | $I_O = 150\text{ mA}$ $V_S = 9\text{ V}$, Pin 3 | V_O | | | 1.0 | V |
| Relay output reverse current | Pin 3 | I_O | | | 0.1 | mA |
| Relay coil resistance | | R_L | 60 | | | Ω |
| Start delay | First bright phase | t_{on} | | | 10 | ms |
| Frequency determining resistor | | R_1 | 6.8 | | 510 | k Ω |
| Frequency determining capacitor | | C_1 | | | 47 | μF |
| Frequency tolerance | Normal flashing, basic frequency f_1 not including the tolerances of the external components R_1 and C_1 | Δf_1 | -5 | | +5 | % |
| Bright period | Basic frequency f_1 $V_S = 9\text{ to }15\text{ V}$ | Δf_1 | 47 | | 53 | % |
| Bright period | Control frequency f_2 $V_S = 9\text{ to }15\text{ V}$ | Δf_2 | 37 | | 45 | % |
| Frequency increase | Lamp failure, $V_S = 9\text{ to }15\text{ V}$ | f_2 | $2.15 \times f_1$ | | $2.3 \times f_1$ | Hz |
| Control signal threshold 1 | $V_S = 15\text{ V}$ $V_S = 9\text{ V}$ $V_S = 12\text{ V}$, Pin 7 | V_{R3} | 50 43 47 | 53 45 49 | 57 47 51 | mV |
| Control signal threshold 2 | | V_{R3} | | | 15 | mV |
| Lamp load | | P_L | 1 | | | W |

Ordering Information

| Extended Type Number | Package | Remarks |
|----------------------|---------|---------|
| U6432B | DIP8 | - |
| U6432B-FP | SO8 | - |

Package Information

DIP8

Package: DIP 8
Dimensions in mm

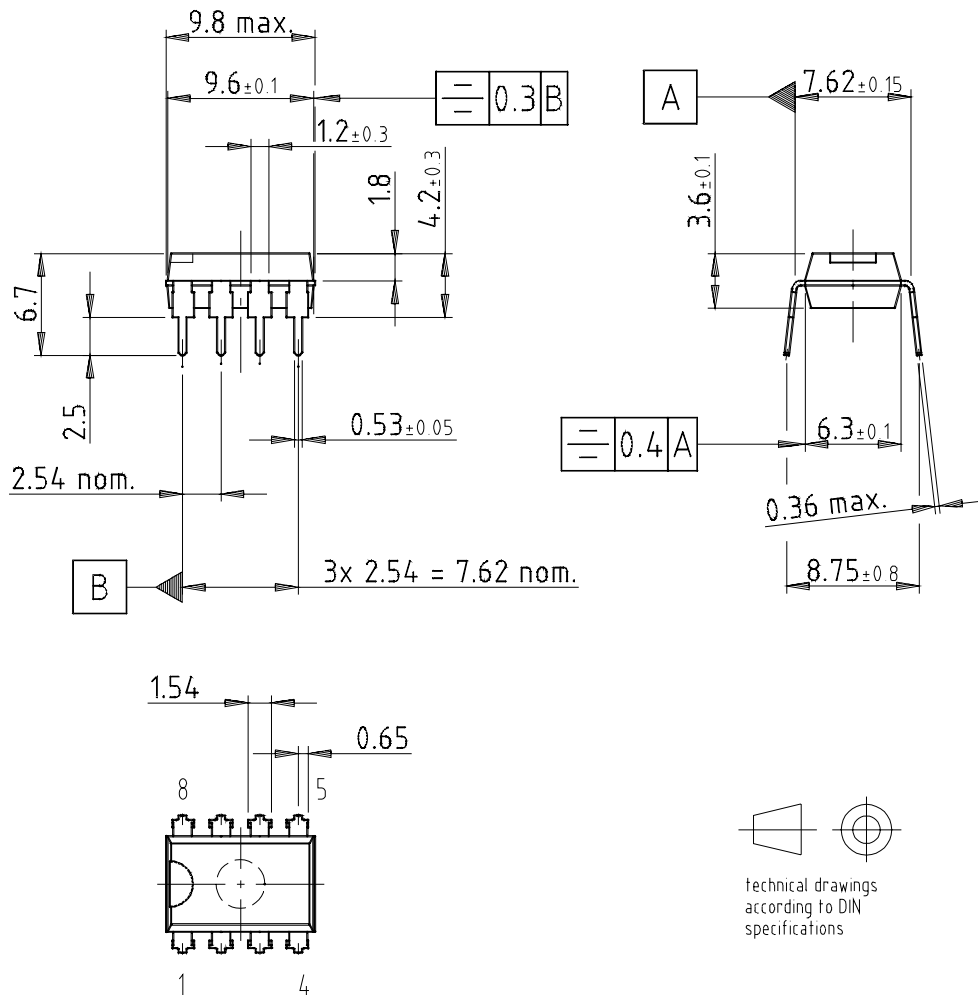

Drawing-No: 6.543-5040.01-4
Issue: 1, 16.01.02

S08

Package S08
Dimensions in mm

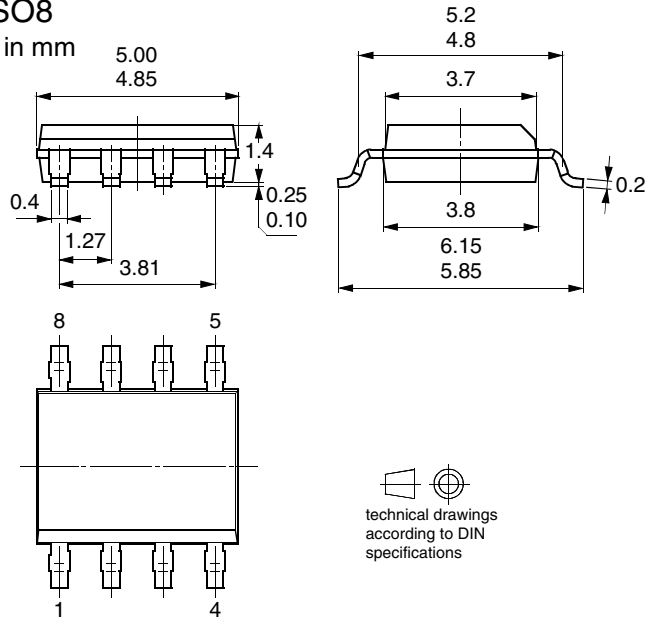



Atmel Corporation

2325 Orchard Parkway
San Jose, CA 95131
Tel: 1(408) 441-0311
Fax: 1(408) 487-2600

Regional Headquarters

Europe

Atmel Sarl
Route des Arsenaux 41
Case Postale 80
CH-1705 Fribourg
Switzerland
Tel: (41) 26-426-5555
Fax: (41) 26-426-5500

Asia

Room 1219
Chinachem Golden Plaza
77 Mody Road Tsimshatsui
East Kowloon
Hong Kong
Tel: (852) 2721-9778
Fax: (852) 2722-1369

Japan

9F, Tonetsu Shinkawa Bldg.
1-24-8 Shinkawa
Chuo-ku, Tokyo 104-0033
Japan
Tel: (81) 3-3523-3551
Fax: (81) 3-3523-7581

Atmel Operations

Memory

2325 Orchard Parkway
San Jose, CA 95131
Tel: 1(408) 441-0311
Fax: 1(408) 436-4314

Microcontrollers

2325 Orchard Parkway
San Jose, CA 95131
Tel: 1(408) 441-0311
Fax: 1(408) 436-4314

La Chantrerie
BP 70602
44306 Nantes Cedex 3, France
Tel: (33) 2-40-18-18-18
Fax: (33) 2-40-18-19-60

ASIC/ASSP/Smart Cards

Zone Industrielle
13106 Rousset Cedex, France
Tel: (33) 4-42-53-60-00
Fax: (33) 4-42-53-60-01

1150 East Cheyenne Mtn. Blvd.
Colorado Springs, CO 80906
Tel: 1(719) 576-3300
Fax: 1(719) 540-1759

Scottish Enterprise Technology Park
Maxwell Building
East Kilbride G75 0QR, Scotland
Tel: (44) 1355-803-000
Fax: (44) 1355-242-743

RF/Automotive

Theresienstrasse 2
Postfach 3535
74025 Heilbronn, Germany
Tel: (49) 71-31-67-0
Fax: (49) 71-31-67-2340

1150 East Cheyenne Mtn. Blvd.
Colorado Springs, CO 80906
Tel: 1(719) 576-3300
Fax: 1(719) 540-1759

Biometrics/Imaging/Hi-Rel MPU/ High Speed Converters/RF Datacom

Avenue de Rochepleine
BP 123
38521 Saint-Egreve Cedex, France
Tel: (33) 4-76-58-30-00
Fax: (33) 4-76-58-34-80

e-mail

literature@atmel.com

Web Site

<http://www.atmel.com>

Disclaimer: Atmel Corporation makes no warranty for the use of its products, other than those expressly contained in the Company's standard warranty which is detailed in Atmel's Terms and Conditions located on the Company's web site. The Company assumes no responsibility for any errors which may appear in this document, reserves the right to change devices or specifications detailed herein at any time without notice, and does not make any commitment to update the information contained herein. No licenses to patents or other intellectual property of Atmel are granted by the Company in connection with the sale of Atmel products, expressly or by implication. Atmel's products are not authorized for use as critical components in life support devices or systems.

© Atmel Corporation 2003. All rights reserved.

Atmel® and combinations thereof are the registered trademarks of Atmel Corporation or its subsidiaries.

Other terms and product names may be the trademarks of others.



Printed on recycled paper.