

NOTES:

1. MATERIAL : LCP, GLASS FILLED, UL 94V-0, BLACK
TERMINAL/SOLDER TAB : COPPER ALLOY
2. FINISHES: SEE TABLE
3. PRODUCT SPECIFICATION : SEE TABLE
4. PACKAGING SPECIFICATION : TAPE AND REEL
5. MATES WITH : MOLEX MICRO SATA PLUG
6. THIS PRODUCT IS COMPLIANT TO RoHS DIRECTIVE WITH THE FOLLOWING BANNED SUBSTANCES - LEAD, MERCURY, CADMIUM, HEXAVALENT CHROMIUM, POLYBROMINATED BIPHENYLS AND POLYBROMINATED DIPHENYLS ETHERS.
7. MOLEX LOGO AND CAVITY NUMBER LOCATED APPROXIMATELY AS SHOWN
8. NON FUNCTIONAL CORING MAY VARY

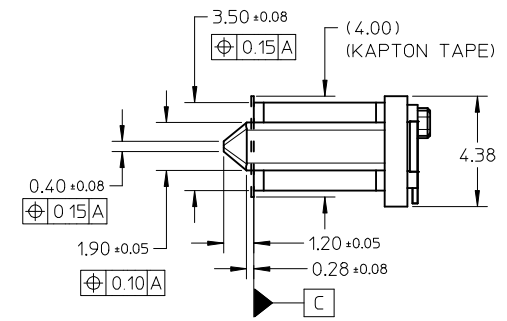

SEE SHEET 4 EC NO: S2009-0967 DRWN:GMENARLY CHKD:CGOH APPR:BOKOK	DESCRIPTION REV	QUALITY SYMBOLS	GENERAL TOLERANCES (UNLESS SPECIFIED)	DIMENSION STYLE	SCALE	DESIGN UNITS	THIRD ANGLE PROJECTION	
		▼=0 ◻=0	mm INCH	MM ONLY	NTS	METRIC		
			4 PLACES ± --- ± --- 3 PLACES ± --- ± --- 2 PLACES ± 0.20 ± --- 1 PLACE ± --- ± ---	DRAWN BY DATE GMENARLY 2009/03/17	TITLE MICRO SATA RECEPTACLE VERTICAL SMT 1.8 INCH SSD/HDD			
			ANGULAR ± 3 °	CHECKED BY DATE CGOH 2009/05/20	MOLEX MOLEX INCORPORATED			
		DRAFT WHERE APPLICABLE MUST REMAIN WITHIN DIMENSIONS	MATERIAL NO.	APPROVED BY DATE BOKOK 2009/05/20	DOCUMENT NO. SD-78492-001		SHEET NO. 1 OF 4	
			SIZE A3	THIS DRAWING CONTAINS INFORMATION THAT IS PROPRIETARY TO MOLEX INCORPORATED AND SHOULD NOT BE USED WITHOUT WRITTEN PERMISSION				

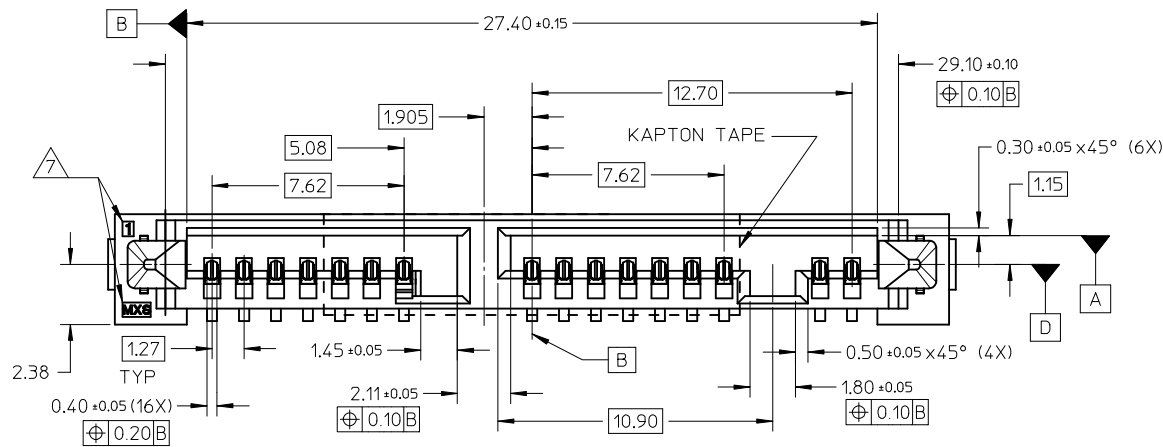
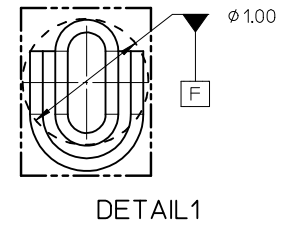
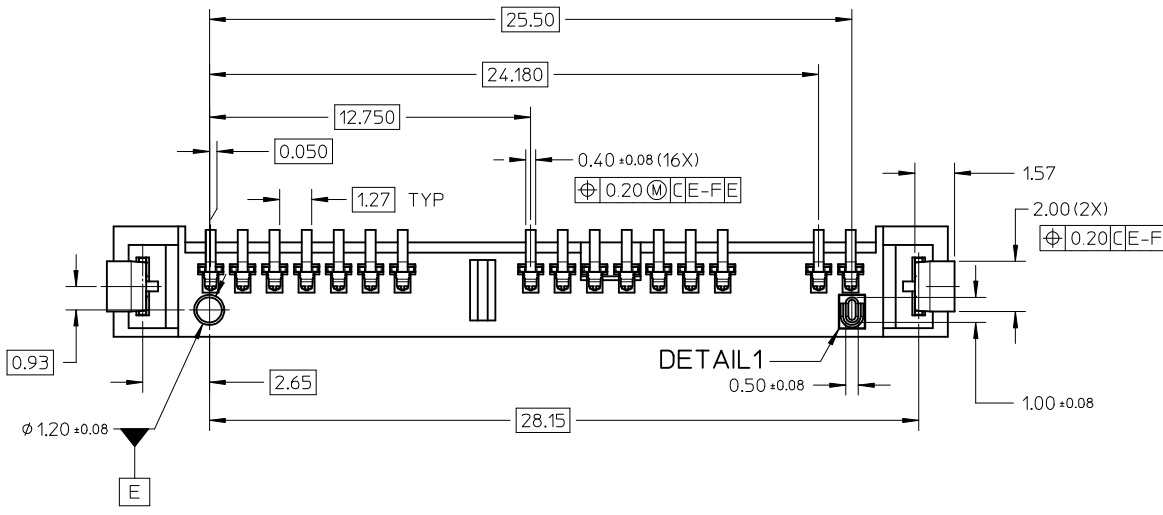
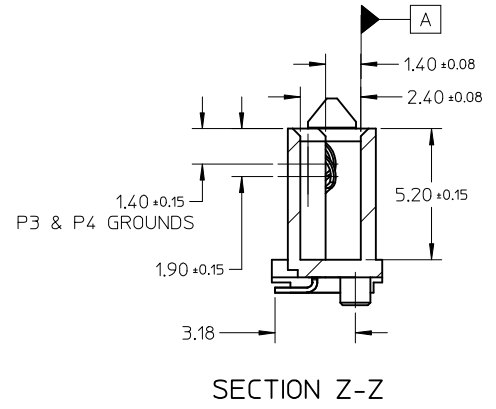
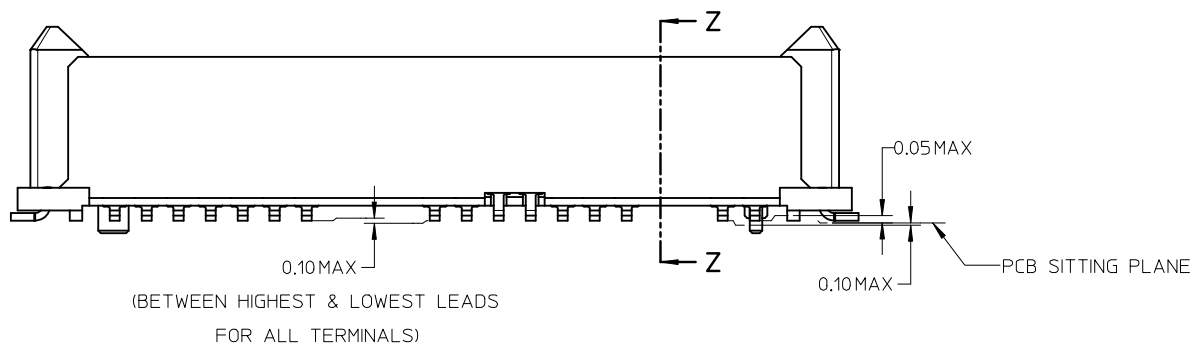

SEE SHEET 4 EC NO: S2009-0967 DRWN:GMENARLY CHKD:CGOH APPR:BOKOK	2009/08/04 2009/08/04 2009/08/05	QUALITY SYMBOLS ▽=0 ◻=0	GENERAL TOLERANCES (UNLESS SPECIFIED)	DIMENSION STYLE MM ONLY	SCALE NTS	DESIGN UNITS METRIC	THIRD ANGLE PROJECTION
	DESCRIPTION A1	4 PLACES ± --- ± --- 3 PLACES ± --- ± --- 2 PLACES ± 0.20 ± --- 1 PLACE ± --- ± --- ANGULAR ± 3 °	mm INCH DRAWN BY GMENARLY CHECKED BY CGOH APPROVED BY BOKOK DATE 2009/03/17 DATE 2009/05/20 DATE 2009/05/20	TITLE MICRO SATA RECEPTACLE VERTICAL SMT 1.8 INCH SSD/HDD	MATERIAL NO. SEE TABLE	DOCUMENT NO. SD-78492-001	SHEET NO. 2 OF 4
	DRAFT WHERE APPLICABLE MUST REMAIN WITHIN DIMENSIONS	SIZE A3	THIS DRAWING CONTAINS INFORMATION THAT IS PROPRIETARY TO MOLEX INCORPORATED AND SHOULD NOT BE USED WITHOUT WRITTEN PERMISSION				
	MOLEX INCORPORATED						

10	9	8	7	6	5	4	3	2	1
PART NUMBER		FINISHES				PRODUCT SPECIFICATIONS			
78492-0001		TERMINAL CONTACT :0.127µm MIN. SELECTIVE GOLD OVER 1.27µm MIN. NICKEL UNDERPLATE TERMINAL SOLDER TAIL :2.54µm MIN. TIN OVER 1.27µm MIN. NICKEL UNDERPLATE SOLDER TAB : 2.54µm MIN. TIN OVER 1.91µm MIN. NICKEL UNDERPLATE				PS-78492-001			
78492-0002		TERMINAL CONTACT :0.38µm MIN. SELECTIVE GOLD OVER 1.27µm MIN. NICKEL UNDERPLATE TERMINAL SOLDER TAIL :2.54µm MIN. TIN OVER 1.27µm MIN. NICKEL UNDERPLATE SOLDER TAB : 2.54µm MIN. TIN OVER 1.91µm MIN. NICKEL UNDERPLATE				PS-78492-002			
78492-0003		TERMINAL CONTACT :0.76µm MIN. SELECTIVE GOLD OVER 1.27µm MIN. NICKEL UNDERPLATE TERMINAL SOLDER TAIL :2.54µm MIN. TIN OVER 1.27µm MIN. NICKEL UNDERPLATE SOLDER TAB : 2.54µm MIN. TIN OVER 1.91µm MIN. NICKEL UNDERPLATE							

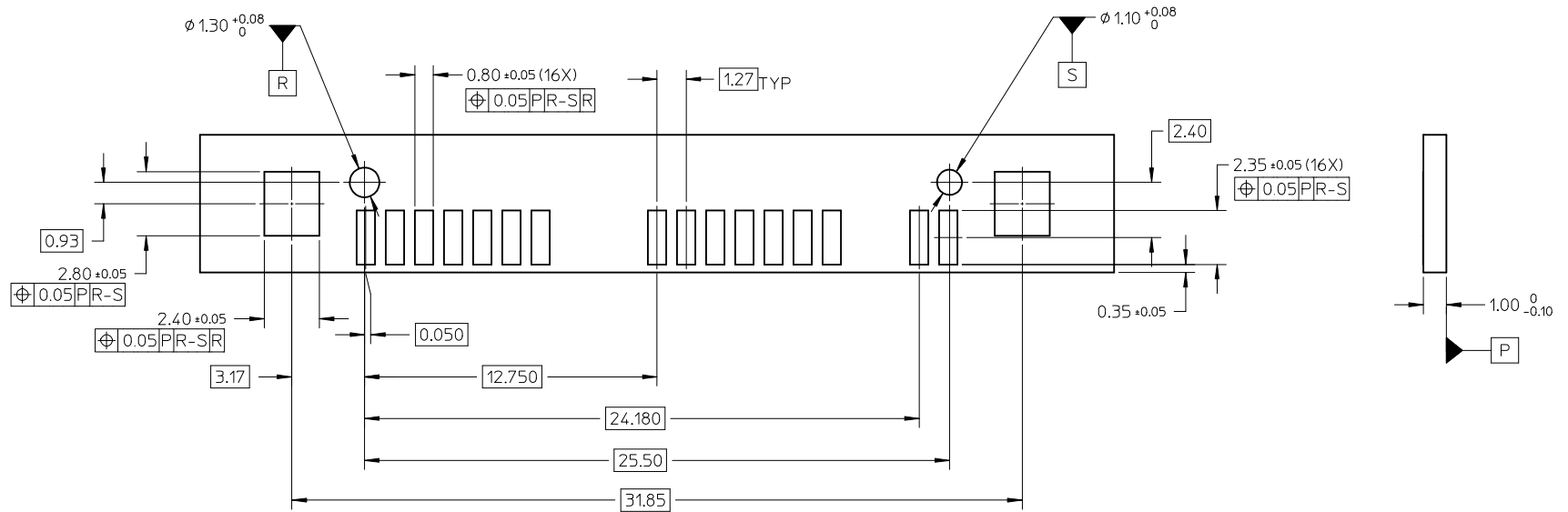

RECOMMENDED PCB LAYOUT

SEE SHEET 4 EC NO: S2009-0967 DRWN:GMENARLY 2009/08/04 CHKD:CGOH 2009/08/04 APPR:BOKOK 2009/08/05	QUALITY SYMBOLS	GENERAL TOLERANCES (UNLESS SPECIFIED)		DIMENSION STYLE MM ONLY		SCALE NTS	DESIGN UNITS METRIC	THIRD ANGLE PROJECTION	
	▽=0 ◻=0	mm	INCH	DRAWN BY GMENARLY	DATE 2009/03/17	TITLE MICRO SATA RECEPTACLE VERTICAL SMT 1.8 INCH SSD/HDD			
		4 PLACES ± --- ± ---	3 PLACES ± --- ± ---	CHECKED BY CGOH	DATE 2009/05/20	MOLEX INCORPORATED			
		2 PLACES ± 0.20 ± ---	1 PLACE ± --- ± ---	APPROVED BY BOKOK	DATE 2009/05/20	DOCUMENT NO. SD-78492-001		SHEET NO. 3 OF 4	
A1	DESCRIPTION	DRAFT WHERE APPLICABLE MUST REMAIN WITHIN DIMENSIONS		SEE TABLE		THIS DRAWING CONTAINS INFORMATION THAT IS PROPRIETARY TO MOLEX INCORPORATED AND SHOULD NOT BE USED WITHOUT WRITTEN PERMISSION			

PACKAGING INFORMATION

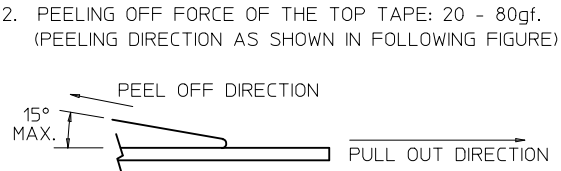
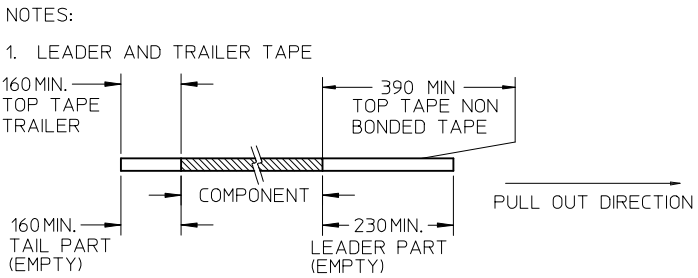
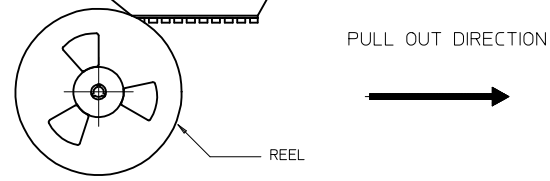
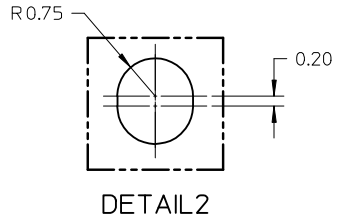
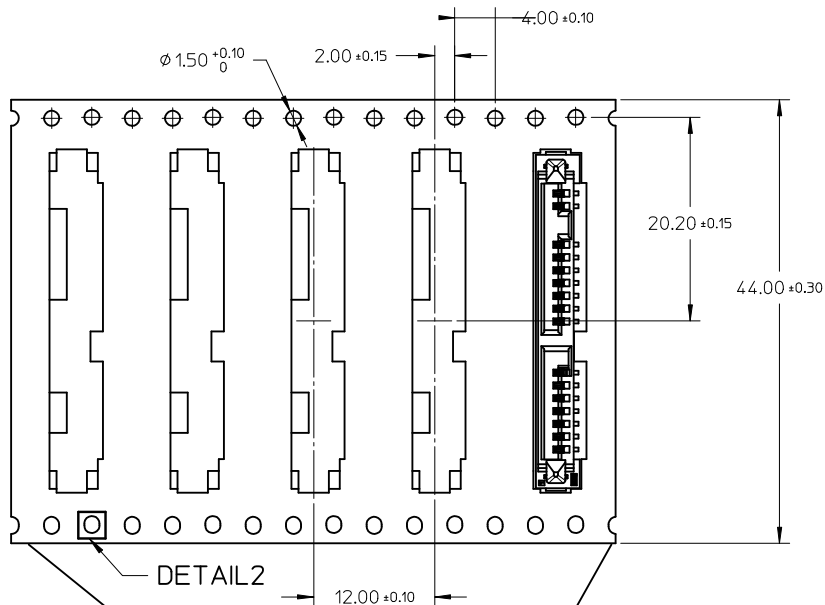

- 3. TAPE AND REEL SPECIFICATION IS AS PER EIA-481.
- 4. TAPE AND REEL QUANTITY : 550 PCS/ REEL.
- 5. THE TAPE IS TREATED FOR ANTI-STATIC.

REV. CARRIER TAPE EC NO: S2009-0967 DRWN:GMENARLY CHKD:CGOH APPR:BOKOK	2009/08/04 2009/08/04 2009/08/05	DESCRIPTION A1	QUALITY SYMBOLS	$\blacktriangledown=0$ $\triangleleft=0$	GENERAL TOLERANCES (UNLESS SPECIFIED)	DIMENSION STYLE	SCALE	DESIGN UNITS	THIRD ANGLE PROJECTION	
						MM ONLY	NTS	METRIC		
						mm	INCH	DRAWN BY	DATE	TITLE
						4 PLACES	± ---	± ---	GMENARLY	2009/03/17
				3 PLACES	± ---	± ---	CHECKED BY	DATE		
				2 PLACES	± 0.20	± ---	CGOH	2009/05/20		
				1 PLACE	± ---	± ---	APPROVED BY	DATE		
					ANGULAR ± 3 °		BOKOK	2009/05/20		
					DRAFT WHERE APPLICABLE MUST REMAIN WITHIN DIMENSIONS		MATERIAL NO.	DOCUMENT NO.	SHEET NO.	
					SEE TABLE		MOLEX INCORPORATED		4 OF 4	
					SIZE A3		THIS DRAWING CONTAINS INFORMATION THAT IS PROPRIETARY TO MOLEX INCORPORATED AND SHOULD NOT BE USED WITHOUT WRITTEN PERMISSION			