

1.8V CMOS Low Jitter XO

FK

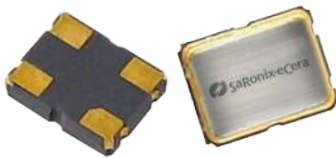

3.2 x 2.5mm Ceramic SMD

Product Features

- 1 to 156.25 MHz Frequency Range
- <1 ps RMS jitter
- 1.8V CMOS compatible logic levels
- Designed for standard reflow and washing techniques
- Low power standby mode
- Pb-free and RoHS/Green compliant

Product Description

The FK Series 1.8V crystal clock oscillator achieves superb stability and low power consumption over a broad range of operating conditions and frequencies. The low jitter output clock signal, generated internally with a non-PLL oscillator design, is compatible with LVCMOS logic levels. The device, available on tape and reel, is contained in a 3.2 x 2.5mm surface-mount ceramic package.

Applications

Ideal for compact, high-density applications requiring low power or tight stability, including:

- Network adapter cards
- Portable Multimedia Devices
- Hard Disk Drives
- GPS/Navigation
- Bluetooth
- 802.11a/b/g WiFi

Package:

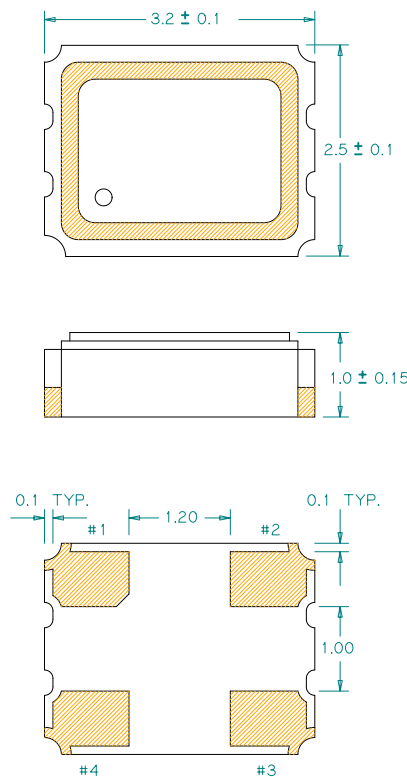

Recommended Land Pattern:

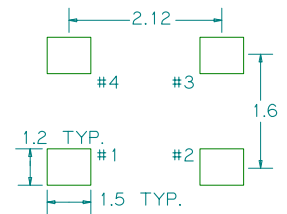

Pin Functions:

Pin	Function
1	OE
2	Ground
3	Clock Output
4	V _{DD}

Part Ordering Information:

FK XXX YYYY

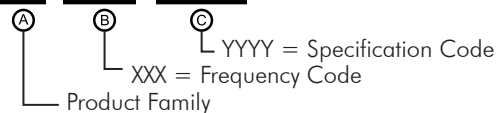

Electrical Performance

Parameter	Min.	Typ.	Max.	Units	Notes
Output Frequency	1		156.25	MHz	As specified
Supply Voltage	1.62	1.8	1.98	V	
Supply Current, Output Enabled			4	mA	1 to 36 MHz
			7		36 to 50 MHz
			10		50 to 70 MHz
			20		70 to 156.25 MHz
Supply Current, Standby Mode			10	μA	Output Hi-Z
Frequency Stability			±20 to ±50	ppm	See Note 1 below
Operating Temperature Range	-20		+70	°C	Commercial (standard)
	-40		+85		Industrial (standard)
Output Logic 0, V _{OL}			10% V _{DD}	V	
Output Logic 1, V _{OH}	90% V _{DD}			V	
Output Load			15	pF	
Duty Cycle	45		55	%	Measured 50% V _{DD}
Rise and Fall Time			5	ns	Measured 10/90% of waveform
Jitter, Phase	1 to 156.25 MHz		1	ps RMS (1-σ)	12kHz to 20 MHz frequency band
Jitter, Accumulated	up to 75 MHz		5	ps RMS (1-σ)	20.000 adjacent periods
	75 to 156.25 MHz		3		
Jitter, Total	up to 75 MHz		50	ps pk-pk	100.000 random periods
	75 to 156.25 MHz		30		

Notes:

- Stability includes all combinations of operating temperature, load changes, rated input (supply) voltage changes, initial calibration tolerance (25°C), aging (1 year at 25°C average effective ambient temperature), shock and vibration.
- For specifications other than those listed, please contact sales.

Output Enable / Disable Function

Parameter	Min.	Typ.	Max.	Units	Notes
Input Voltage (pin 1), Output Enable	0.7 V _{DD}			V	or open
Input Voltage (pin 1), Output Disable (low power standby)			0.3 V _{DD}	V	Output is Hi-Z
Internal Pullup Resistance	50			kΩ	
Output Disable Delay			200	ns	
Output Enable Delay			10	ms	

Absolute Maximum Ratings

Parameter	Min.	Typ.	Max.	Units	Notes
Storage Temperature	-55		+125	°C	

For the latest product information visit: <http://www.pericom.com/products/timing/oscillators/FK1.8/>

For test circuit go to: http://www.pericom.com/pdf/sre/tc_hcm052.pdf

For soldering reflow profile and reliability test ratings go to: <http://www.pericom.com/pdf/sre/reflow.pdf>

For tape and reel information go to: http://www.pericom.com/pdf/sre/tr_3225_xo.pdf