

PRODUCT NO.  
92194

PRODUCT NO. *92194-XXXXX	STAND OFF DIM "M"(mm)	UPPER DECK			LOWER DECK			DIM "P" (mm)	HDR COLOR	SHEET NO.	MOUNTING STYLE TO PCB & DIRECTION OF PUSH ROD
		(MECH+HDR) 92711-XXXXX	(MECH) 92192-XXXX	(HDR) 92140-XXX	(MECH+HDR) 92193-XXXXX	(MECH) 92192-XXXX	(HDR) 92140-XXX				
000CA	0	000CA	00CA	005	100CA	10CA	000	2.8	BLACK	NO.2	
000CALF	0	000CALF	00CA	005LF	100CALF	10CA	000LF	2.8	BLACK		
020CA	2	020CA	00CA	045	120CA	12CA	040	2.5	BLACK		
020CALF	2	020CALF	00CA	045LF	120CALF	12CA	040LF	2.5	BLACK	NO.3	
100CA	0	100CA	10CA	005	000CA	00CA	000	2.8	BLACK		
100CALF	0	100CALF	10CA	005LF	000CALF	00CA	000LF	2.8	BLACK		
120CA	2	120CA	10CA	045	020CA	02CA	040	2.5	BLACK	NO.4	
120CALF	2	120CALF	10CA	045LF	020CALF	02CA	040LF	2.5	BLACK		
200CA	0	000CA	00CA	005	000CA	00CA	000	2.8	BLACK		
200CALF	0	000CALF	00CA	005LF	000CALF	00CA	000LF	2.8	BLACK	NO.5	
200FA	0	000FA	00FA	005	000FA	00FA	000	2.8	BLACK		
200FALF	0	000FALF	00FA	005LF	000FALF	00FA	000LF	2.8	BLACK		
220CA	2	020CA	00CA	045	020CA	02CA	040	2.5	BLACK	NO.6	
220CALF	2	020CALF	00CA	045LF	020CALF	02CA	040LF	2.5	BLACK		
300CA	0	100CA	10CA	005	100CA	10CA	000	2.8	BLACK		
300CALF	0	100CALF	10CA	005LF	100CALF	10CA	000LF	2.8	BLACK	NO.7	
320CA	2	120CA	10CA	045	120CA	12CA	040	2.5	BLACK		
320CALF	2	120CALF	10CA	045LF	120CALF	12CA	040LF	2.5	BLACK		
320FA	2	120FA	10FA	045	120FA	12FA	040	2.5	BLACK	NO.8	
320FALF	2	120FALF	10FA	045LF	120FALF	12FA	040LF	2.5	BLACK		
320GALF	2	120GALF	10CA	045LF	120GALF	12GALF	040LF	2.5	BLACK		
500CA	0	600CA	00CA	505	500CA	10CA	500	2.8	NATURAL	NO.9	
500CALF	0	600CALF	00CA	505LF	500CALF	10CA	500LF	2.8	NATURAL		
500FA	0	600FA	00FA	505	500FA	10FA	500	2.8	NATURAL		
500FALF	0	600FALF	00FA	505LF	500FALF	10FA	500LF	2.8	NATURAL		
520CA	2	620CA	00CA	545	520CA	12CA	540	2.5	NATURAL		
520CALF	2	620CALF	00CA	545LF	520CALF	12CA	540LF	2.5	NATURAL		
600CA	0	500CA	10CA	505	600CA	00CA	500	2.8	NATURAL		
600CALF	0	500CALF	10CA	505LF	600CALF	00CA	500LF	2.8	NATURAL		
620CA	2	520CA	10CA	545	620CA	02CA	540	2.5	NATURAL		
620CALF	2	520CALF	10CA	545LF	620CALF	02CA	540LF	2.5	NATURAL		
700CA	0	500CA	10CA	505	500CA	10CA	500	2.8	NATURAL		
700CALF	0	500CALF	10CA	505LF	500CALF	10CA	500LF	2.8	NATURAL		
720CA	2	520CA	10CA	545	520CA	12CA	540	2.5	NATURAL		
720CALF	2	520CALF	10CA	545LF	520CALF	12CA	540LF	2.5	NATURAL		
800CA	0	600CA	00CA	505	600CA	00CA	500	2.8	NATURAL		
800CALF	0	600CALF	00CA	505LF	600CALF	00CA	500LF	2.8	NATURAL		
820CA	2	620CA	00CA	545	620CA	02CA	540	2.5	NATURAL		
820CALF	2	620CALF	00CA	545LF	620CALF	02CA	540LF	2.5	NATURAL		

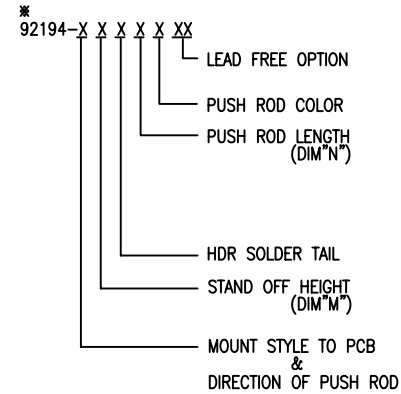

NONE : NO  
LF : YES (SEE NOTE5)

A : BLACK  
C : 13mm  
F : 21mm  
G : 27mm

0 : R/A

0 : 0mm(NONE)  
2 : 2mm

- 0 : TOP MOUNT & RIGHT-LEFT PUSH ROD
- 1 : TOP MOUNT & LEFT-RIGHT PUSH ROD
- 2 : TOP MOUNT & RIGHT-RIGHT PUSH ROD
- 3 : TOP MOUNT & LEFT-LEFT PUSH ROD
- 5 : BOTTOM MOUNT & RIGHT-LEFT PUSH ROD
- 6 : BOTTOM MOUNT & LEFT-RIGHT PUSH ROD
- 7 : BOTTOM MOUNT & RIGHT-RIGHT PUSH ROD
- 8 : BOTTOM MOUNT & LEFT-LEFT PUSH ROD

NOTE  
1. THIS PRODUCT MEETS EUROPEAN UNION DIRECTIVES AND OTHER COUNTRY REGULATIONS AS DESCRIBED IN GS-22-008.  
2. PRODUCT SPEC: 110-263

mat'l. code		surface ISO1302		tolerance ISO1302 ISO1101		projection		product family PCMCIA	
ltr		ecn no		dr		date		title	
H		ELX-N-007950		ZK		11/01/11		68P DOUBLE EJECTOR HEADER ASSY FOR TYPE I/II/III	
J		ELX-N-011430		ZK		04/23/12		scale 2:1	
K		ELX-N-20919		J.H		05/27/15		sheet. 1 of 9	
				dr		M.HASEGAWO		06/17/05	
				engr		M.HASEGAWO		06/17/05	
F		V04-0820		M.H		08/16/04		chr	
G		J05-0367		M.H		6/17/05		app	
sheet		revision		k				FCI	
index		sheet		1-9				92194	
								type Product Customer Drawing	
								A4	

PART NO.	
92194-000CA	92194-000CALF
92194-020CA	92194-020CALF

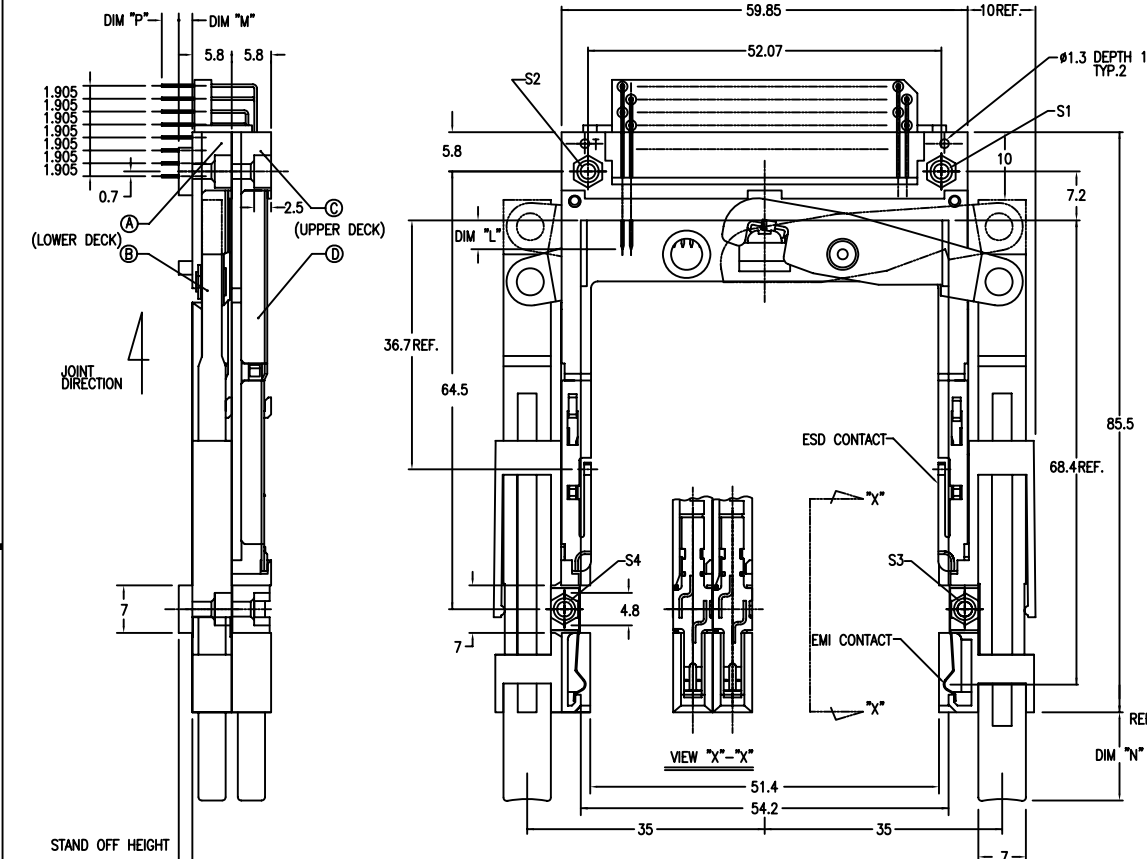

VIEW "X"-X"

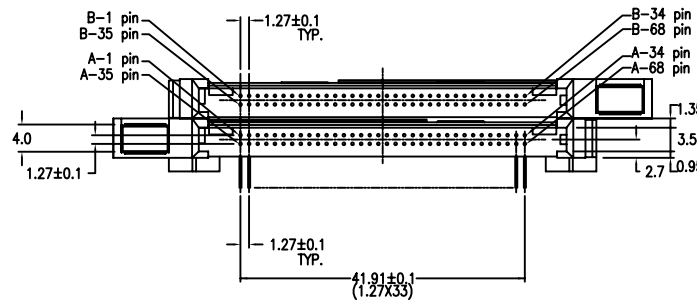

NOTE

- EJECT FORCE 3.5kg MAX.
- ASSY PROCESS  
2.1 TO MOUNT PART ④, ⑤ ON PWB WITH SCREW (S1,S2) AND SOLDER.  
2.2 TO JOINT PART ④, ⑤ INTO PART ① THEN FIX PART ④, ⑤ WITH 2 SCREWS (S3,S4).
- EJECT TRAVEL 8.0mm

④ MATERIAL  
4.1 PART ④, ⑤ (HEADER ASSY)  
PLASTIC : HIGH TEMPERATURE THERMOPLASTIC UL94V-0 BLACK  
PIN : COPPER ALLOY

4.2 PART ④, ⑤ (EJECT MECHANISM ASSY)  
PLASTIC : HIGH TEMPERATURE THERMOPLASTIC UL94V-0 BLACK  
PLATE : STAINLESS  
EMI CONTACT : COPPER ALLOY

- ⑤ -1 FINISH (PIN)  
UNDER PLATING : 0.5 μm MIN. Ni  
CONTACT AREA : 0.076 μm MIN. GOLD  
SOLDER TAIL : 2.5 μm MIN. Sn-Pb.
- ⑤ -2 FINISH (PIN) (FOR -\*\*\*\*#F)  
UNDER PLATING : 0.5 μm MIN. Ni  
CONTACT AREA : 0.076 μm MIN. GOLD  
SOLDER TAIL : 2.5 μm MIN. Sn.

6.	DIM "L"	4.25±0.1	3.5±0.1	5.0±0.1
	PIN NUMBER	OTHERS	36.67	35.66

- GENERAL TOLERANCE : ±0.3
- SEE SHEET 1 REGARDING COMPONENTS

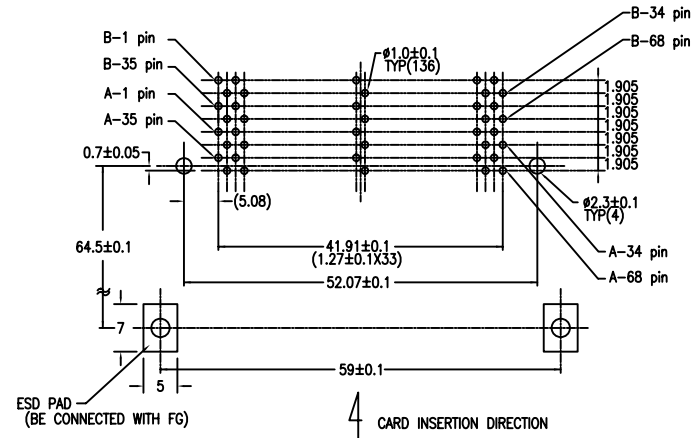

mat'l. code	surface	tolerance	projection	product family
	ISO1302	ISO1302 ISO1101		PCMCIA
ltr	ecn no	dr	date	title
K				68P DOUBLE EJECTOR HEADER ASSY FOR TYPE I/II/III
	angles			dwg no
	0°±x'	0.XX±0.13	0.XXX±0.05	sheet. 2 of 9
	dr	M.HASEGAWO	06/17/05	size
	enrg	M.HASEGAWO	06/17/05	A4
	chr	M.HASEGAWO	06/20/05	
	appd	M.HASEGAWO	06/20/05	type
				Product Customer Drawing
sheet	revision			
index	sheet			

PRODUCT NO.	
92194-100CA	92194-100CALF
92194-120CA	92194-120CALF

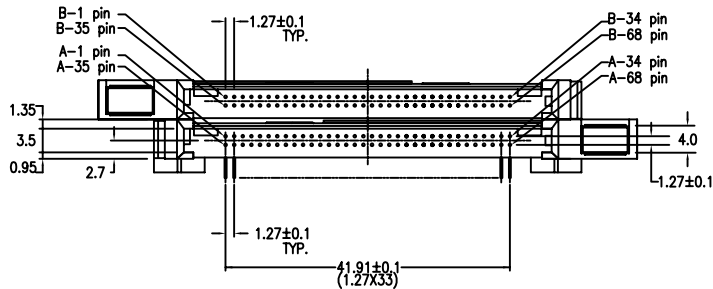
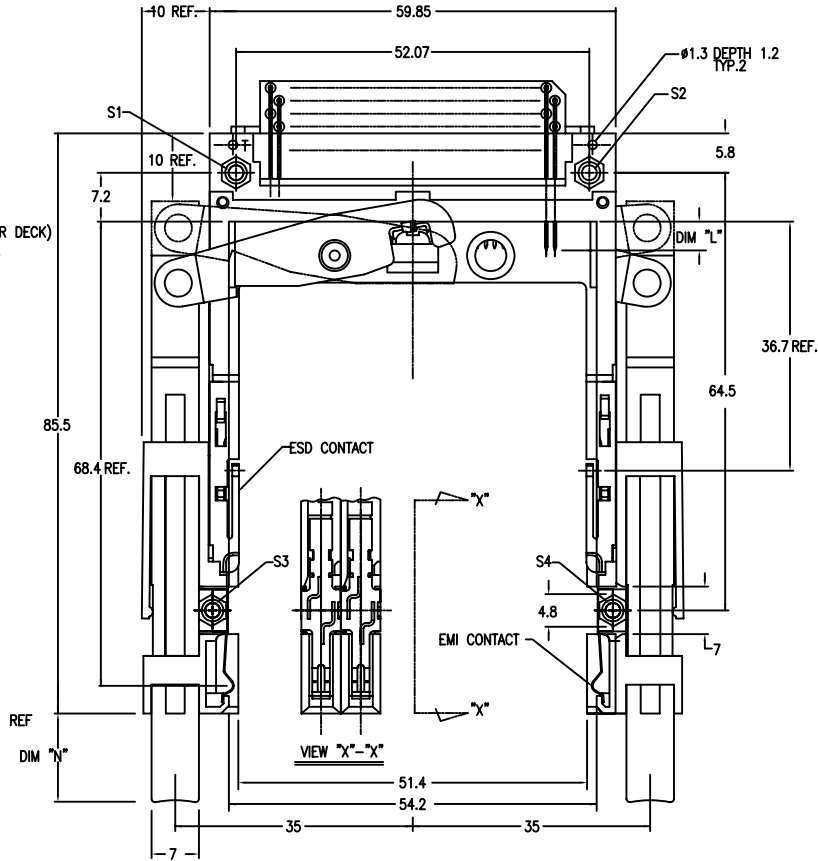
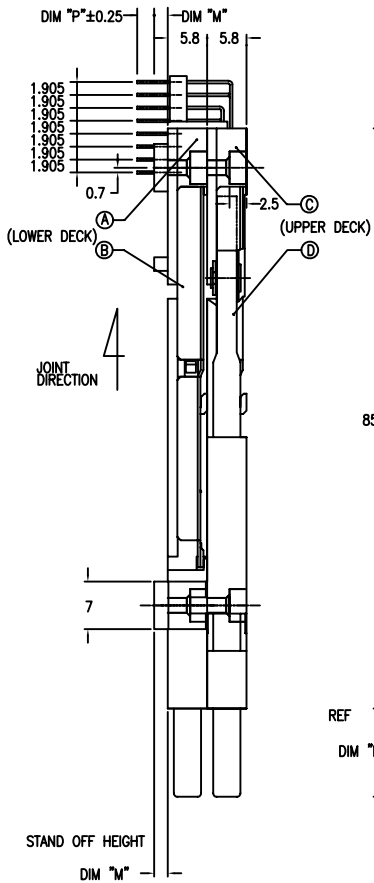

NOTE

- EJECT FORCE 3.5kg MAX.
- ASSY PROCESS
  - TO MOUNT PART ④, ⑤ ON PWB WITH SCREW (S1,S2) AND SOLDER.
  - TO JOINT PART ④, ⑤ INTO PART ③ THEN FIX PART ④, ⑤ WITH 2 SCREWS (S3,S4).
- EJECT TRAVEL 8.0mm
- MATERIAL
  - PART ④, ⑤ (HEADER ASSY)  
PLASTIC : HIGH TEMPERATURE THERMOPLASTIC UL94V-0 BLACK  
PIN : COPPER ALLOY
  - PART ③, ⑥ (EJECT MECHANISM ASSY)  
PLASTIC : HIGH TEMPERATURE THERMOPLASTIC UL94V-0 BLACK  
PLATE : STAINLESS  
EMI CONTACT : COPPER ALLOY
- FINISH (PIN)
  - FINISH (PIN)  
UNDER PLATING : 0.5 μm MIN. Ni  
CONTACT AREA : 0.076 μm MIN. GOLD  
SOLDER TAIL : 2.5 μm MIN. Sn-Pb.
  - FINISH (PIN) (FOR \*\*\*\*\*LF)  
UNDER PLATING : 0.5 μm MIN. Ni  
CONTACT AREA : 0.076 μm MIN. GOLD  
SOLDER TAIL : 2.5 μm MIN. Sn.

DIM 'L'	4.25±0.1	3.5±0.1	5.0±0.1
PIN NUMBER	1734	36.67	3521.68

- GENERAL TOLERANCE : ±0.3
- SEE SHEET 1 REGARDING COMPONENTS

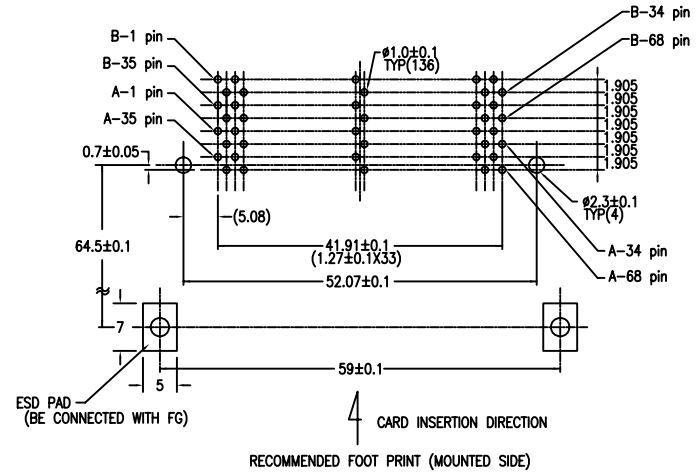

mat'l. code	surface	tolerance	projection	product family
	ISO1302	ISO1302 ISO1101		PCMCIA
ltr	ecn no	dr	date	title
K				68P DOUBLE EJECTOR HEADER ASSY FOR TYPE I/II/III
				dwg no
				92194
				sheet. 3 of 9
				size
				A4
				type
				Product Customer Drawing
sheet	revision			
index	sheet			



PRODUCT NO.	
92194-300CA	92194-300CALF
92194-320CA	92194-320CALF
92194-320FA	92194-320FALF
92194-320GALF	

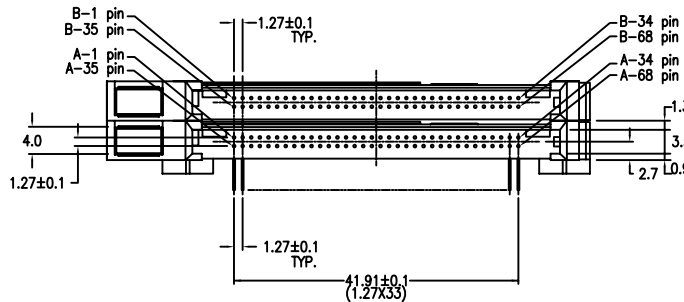
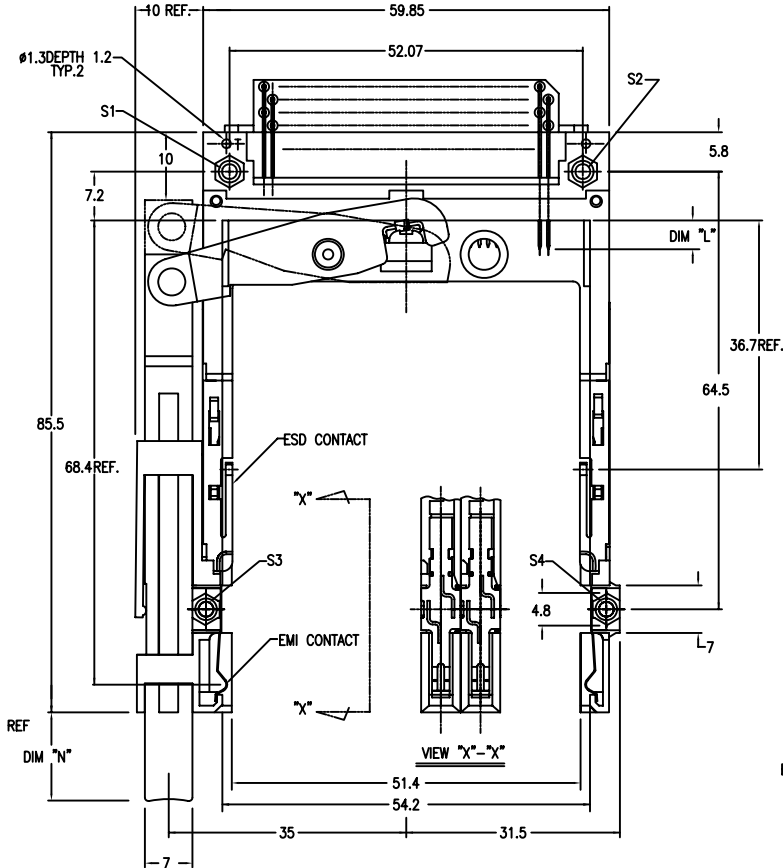
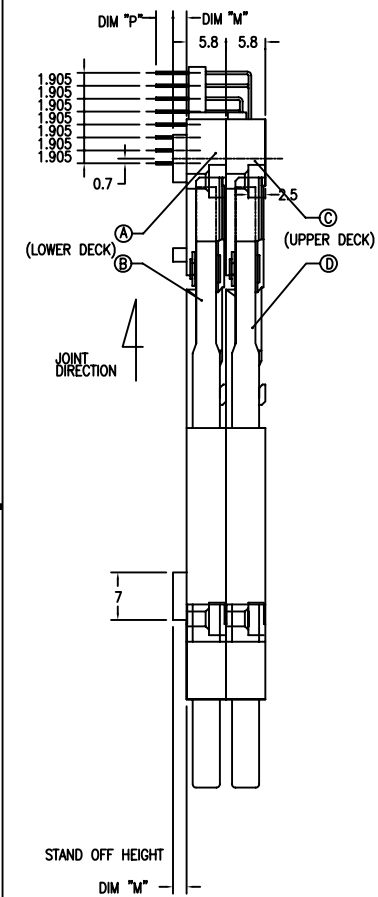

NOTE

- EJECT FORCE 3.5kg MAX.
- ASSY PROCESS
  - TO MOUNT PART ④, ⑤ ON PWB WITH SCREW (S1,S2) AND SOLDER.
  - TO JOINT PART ③, ⑥ INTO PART ② THEN FIX PART ③, ⑥ WITH 2 SCREWS (S3,S4).
- EJECT TRAVEL 8.0mm
- MATERIAL
  - PART ②, ③ (HEADER ASSY)
    - PLASTIC : HIGH TEMPERATURE THERMOPLASTIC UL94V-0 BLACK
    - PIN : COPPER ALLOY
  - PART ④, ⑤ (EJECT MECHANISM ASSY)
    - PLASTIC : HIGH TEMPERATURE THERMOPLASTIC UL94V-0 BLACK
    - PLATE : STAINLESS
    - EMI CONTACT : COPPER ALLOY
- FINISH (PIN)
  - FINISH (PIN)
    - UNDER PLATING : 0.5 μm MIN. Ni
    - CONTACT AREA : 0.076 μm MIN. GOLD
    - SOLDER TAIL : 2.5 μm MIN. Sn-Pb.
  - FINISH (PIN) (FOR -\*\*\*\*LF)
    - UNDER PLATING : 0.5 μm MIN. Ni
    - CONTACT AREA : 0.076 μm MIN. GOLD
    - SOLDER TAIL : 2.5 μm MIN. Sn.
- |            |          |         |         |
|------------|----------|---------|---------|
| DIM "L"    | 4.25±0.1 | 3.5±0.1 | 5.0±0.1 |
| PIN NUMBER | OTHERS   | 36.67   | 36.31   |
- GENERAL TOLERANCE : ±0.3
- SEE SHEET 1 REGARDING COMPONENTS

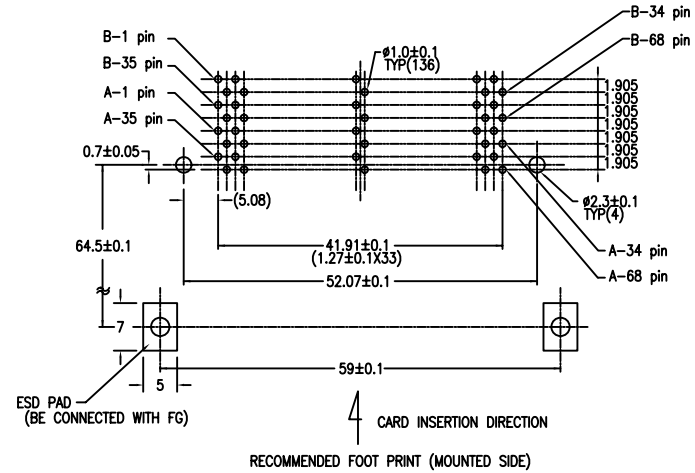

mat'l. code	surface	tolerance	projection	product family
	ISO1302	ISO1302 ISO1101		PCMCIA
ltr	ecn no	dr	date	title
K				68P DOUBLE EJECTOR HEADER ASSY FOR TYPE I/II/III
				dwg no
				92194
				sheet. 5 of 9
				size
				A4
				type
				Product Customer Drawing
sheet index	revision sheet			

PART NO.	
92194-500CA	92194-500CALF
92194-500FA	92194-500FALF
92194-520CA	92194-520CALF

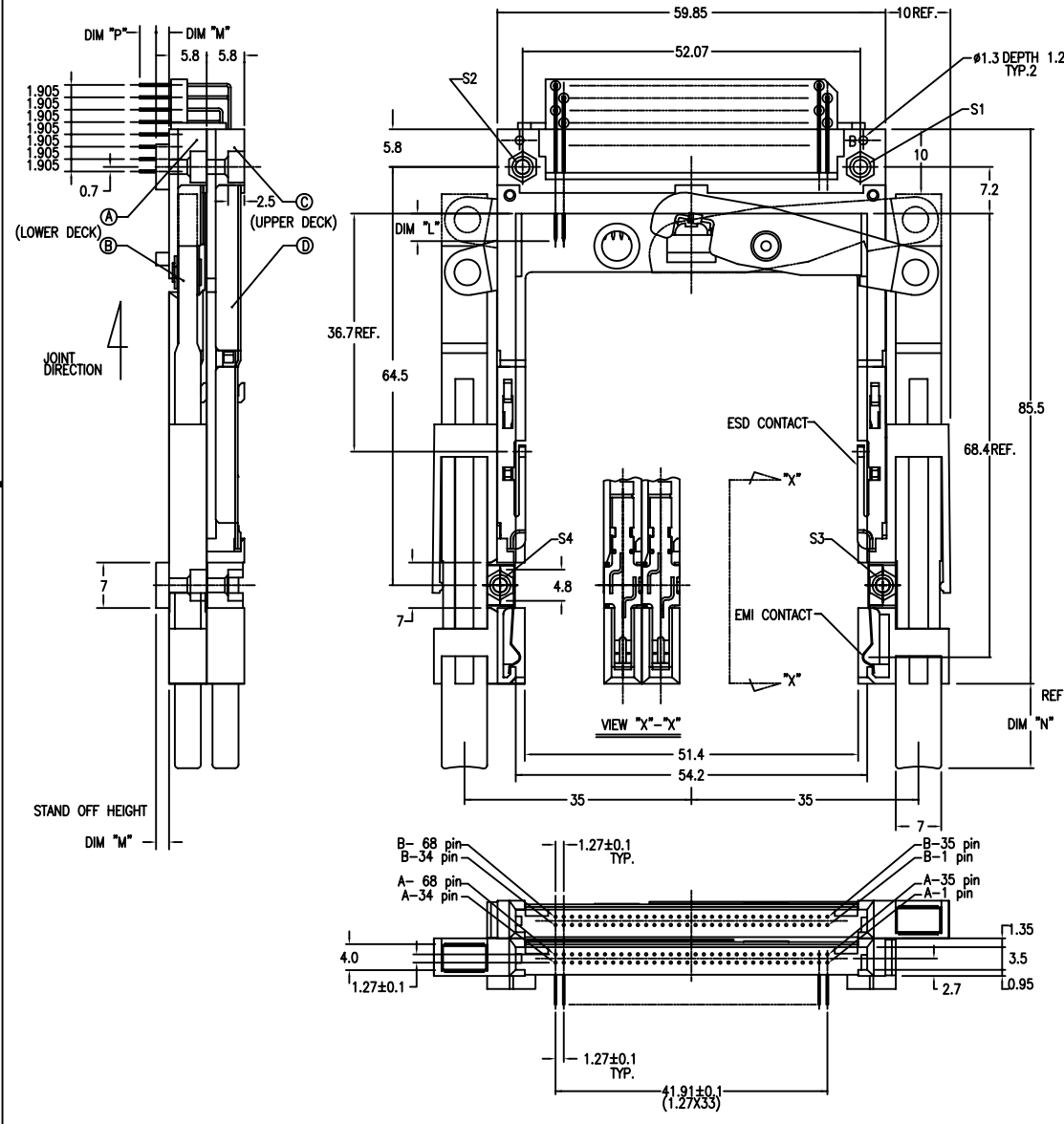

NOTE  
 1. EJECT FORCE 3.5kg MAX.  
 2. ASSY PROCESS  
 2.1 TO MOUNT PART ②, ③ ON PWB WITH SCREW (S1,S2) AND SOLDER.  
 2.2 TO JOINT PART ②, ③ INTO PART ④ THEN FIX PART ②, ③ WITH 2 SCREWS (S3,S4).  
 3. EJECT TRAVEL 8.0mm  
 ④ MATERIAL

4.1 PART ②, ③ (HEADER ASSY)  
 PLASTIC : HIGH TEMPERATURE THERMOPLASTIC UL94V-0 BLACK  
 PIN : COPPER ALLOY

4.2 PART ②, ③ (EJECT MECHANISM ASSY)  
 PLASTIC : HIGH TEMPERATURE THERMOPLASTIC UL94V-0 BLACK  
 PLATE : STAINLESS  
 EMI CONTACT : COPPER ALLOY

⑤ -1 FINISH (PIN)  
 UNDER PLATING : 0.5 μm MIN. Ni  
 CONTACT AREA : 0.076 μm MIN. GOLD  
 SOLDER TAIL : 2.5 μm MIN. Sn-Pb.  
 ⑤ -2 FINISH (PIN) (FOR -\*\*\*\*\*LF)  
 UNDER PLATING : 0.5 μm MIN. Ni  
 CONTACT AREA : 0.076 μm MIN. GOLD  
 SOLDER TAIL : 2.5 μm MIN. Sn.

DIM "L"	4.25±0.1	3.5±0.1	5.0±0.1
PIN NUMBER	OTHERS	36.67	36.67

7. GENERAL TOLERANCE : ±0.3  
 8. SEE SHEET 1 REGARDING COMPONENTS

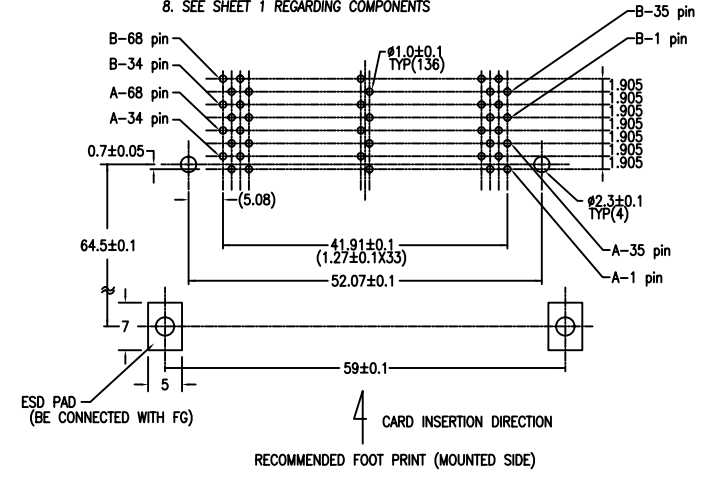

mat'l. code	surface	tolerance	projection	product family		
	ISO1302	ISO1302 ISO1101		PCMCIA		
ltr	ecn no	dr	date	title		
K				68P DOUBLE EJECTOR HEADER ASSY FOR TYPE I/II/III		
				scale 2:1		
	dr	M.HASEGAWO	06/17/05			
	engr	M.HASEGAWO	06/17/05			
	chr	M.HASEGAWO	06/20/05			
	appd	M.HASEGAWO	06/20/05			
sheet	revision			dwg no	sheet. 6 of 9	size
index	sheet			92194	A4	
				type	Product Customer Drawing	

PART NO.	
92194-600CA	92194-600CALF
92194-620CA	92194-620CALF

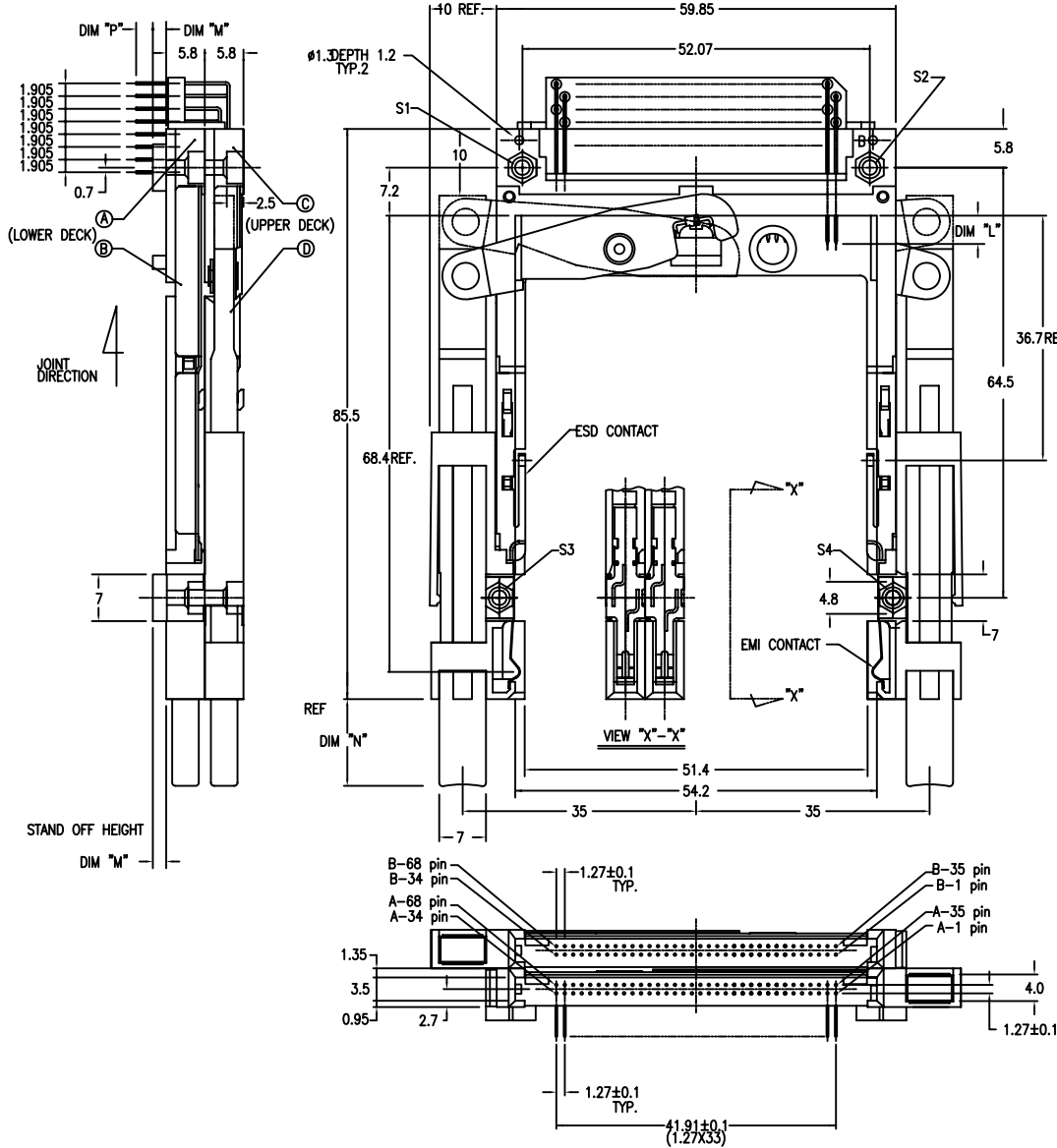

NOTE  
 1. EJECT FORCE 3.5kg MAX.  
 2. ASSY PROCESS  
 2.1 TO MOUNT PART (A), (C) ON PWB WITH SCREW (S1,S2) AND SOLDER.  
 2.2 TO JOINT PART (B), (D) INTO PART (A), (C) THEN FIX PART (B), (D) WITH 2 SCREWS (S3,S4).  
 3. EJECT TRAVEL 8.0mm

4. MATERIAL  
 4.1 PART (A), (C) (HEADER ASSY)  
 PLASTIC : HIGH TEMPERATURE THERMOPLASTIC UL94V-0 BLACK  
 PIN : COPPER ALLOY

4.2 PART (B), (D) (EJECT MECHANISM ASSY)  
 PLASTIC : HIGH TEMPERATURE THERMOPLASTIC UL94V-0 BLACK  
 PLATE : STAINLESS  
 EMI CONTACT : COPPER ALLOY

5-1 FINISH (PIN)  
 UNDER PLATING : 0.5 μm MIN. Ni  
 CONTACT AREA : 0.076 μm MIN. GOLD  
 SOLDER TAIL : 2.5 μm MIN. Sn-Pb.

5-2 FINISH (PIN) (FOR -\*\*\*\*LF)  
 UNDER PLATING : 0.5 μm MIN. Ni  
 CONTACT AREA : 0.076 μm MIN. GOLD  
 SOLDER TAIL : 2.5 μm MIN. Sn.

6.	DIM "L"	4.25±0.1	3.5±0.1	5.0±0.1
	PIN NUMBER	OTHERS	36.67	1734 36.5168

7. GENERAL TOLERANCE : ±0.3

8. SEE SHEET 1 REGARDING COMPONENTS

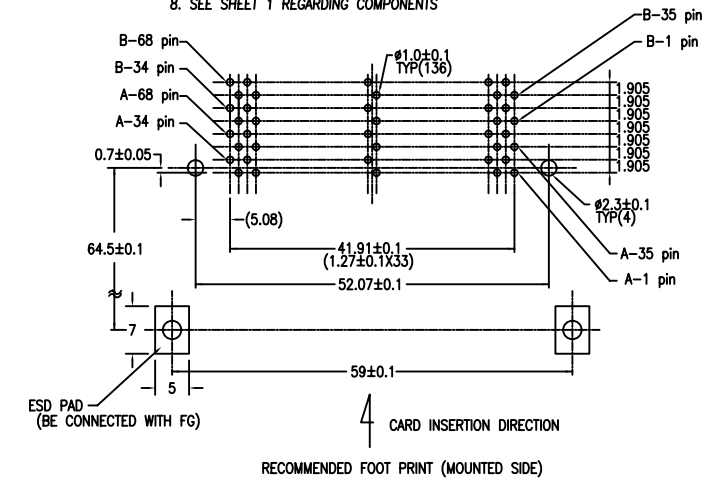

mat'l. code	surface	tolerance	projection	product family
	ISO1302	ISO1302 ISO1101		PCMCIA
ltr	ecn no	dr	date	title
K				68P DOUBLE EJECTOR HEADER ASSY FOR TYPE I/II/III
				dwg no
				92194
				sheet. 7 of 9
				size
				A4
				type
				Product Customer Drawing
sheet	revision			
index	sheet			

PART NO.	
92194-700CA	92194-700CALF
92194-720CA	92194-720CALF

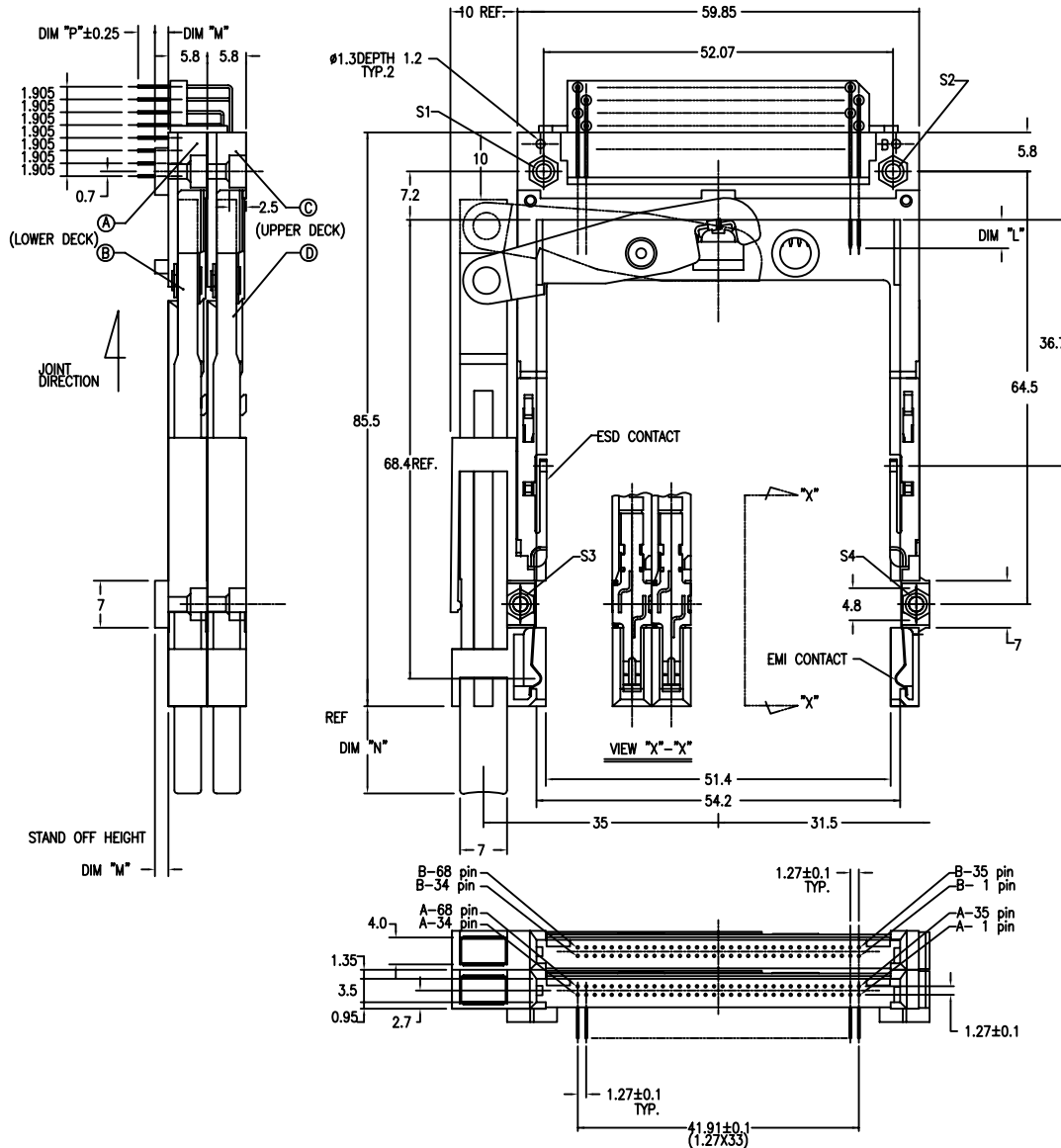

NOTE

- EJECT FORCE 3.5kg MAX.
- ASSY PROCESS
  - TO MOUNT PART ④, ⑤ ON PWB WITH SCREW (S1,S2) AND SOLDER.
  - TO JOINT PART ③, ① INTO PART ④ THEN FIX PART ②, ⑥ WITH 2 SCREWS (S3,S4).
- EJECT TRAVEL 8.0mm

④ MATERIAL

4.1 PART ④, ⑤ (HEADER ASSY)  
 PLASTIC : HIGH TEMPERATURE THERMOPLASTIC UL94V-0 BLACK  
 PIN : COPPER ALLOY

4.2 PART ③, ① (EJECT MECHANISM ASSY)  
 PLASTIC : HIGH TEMPERATURE THERMOPLASTIC UL94V-0 BLACK  
 PLATE : STAINLESS  
 EMI CONTACT : COPPER ALLOY

⑤ -1 FINISH (PIN)

UNDER PLATING : 0.5  $\mu$ m MIN. Ni  
 CONTACT AREA : 0.076  $\mu$ m MIN. GOLD  
 SOLDER TAIL : 2.5  $\mu$ m MIN. Sn-Pb.

⑤ -2 FINISH (PIN) (FOR -\*\*\*\*LF)

UNDER PLATING : 0.5  $\mu$ m MIN. Ni  
 CONTACT AREA : 0.076  $\mu$ m MIN. GOLD  
 SOLDER TAIL : 2.5  $\mu$ m MIN. Sn.

DIM "L"	4.25±0.1	3.5±0.1	5.0±0.1
PIN NUMBER	OTHERS	36,67	36,68

7. GENERAL TOLERANCE : ±0.3

8. SEE SHEET 1 REGARDING COMPONENTS

REF.

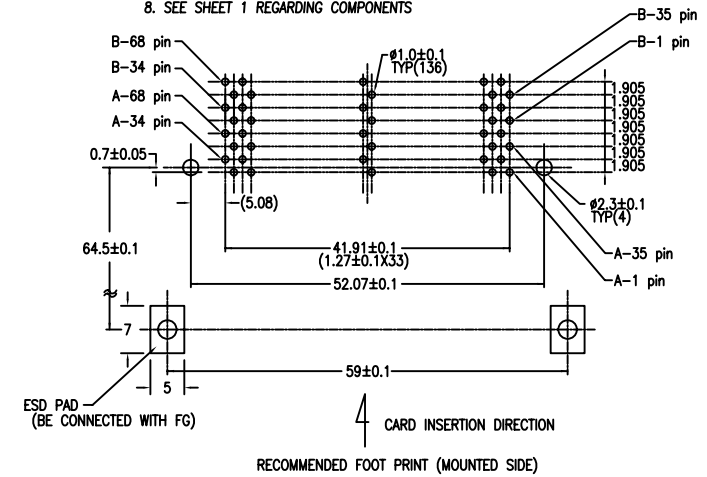

mat'l. code	surface	tolerance	projection	product family
	ISO1302	ISO1302 ISO1101		PCMCIA
ltr	ecn no	dr	date	title
K				68P DOUBLE EJECTOR HEADER ASSY FOR TYPE I/II/III
				dwg no
				92194
				sheet. 8 of 9
				size
				A4
				type
				Product Customer Drawing
sheet	revision			
index	sheet			



PART NO.	
92194-800CA	92194-800CALF
92194-820CA	92194-820CALF

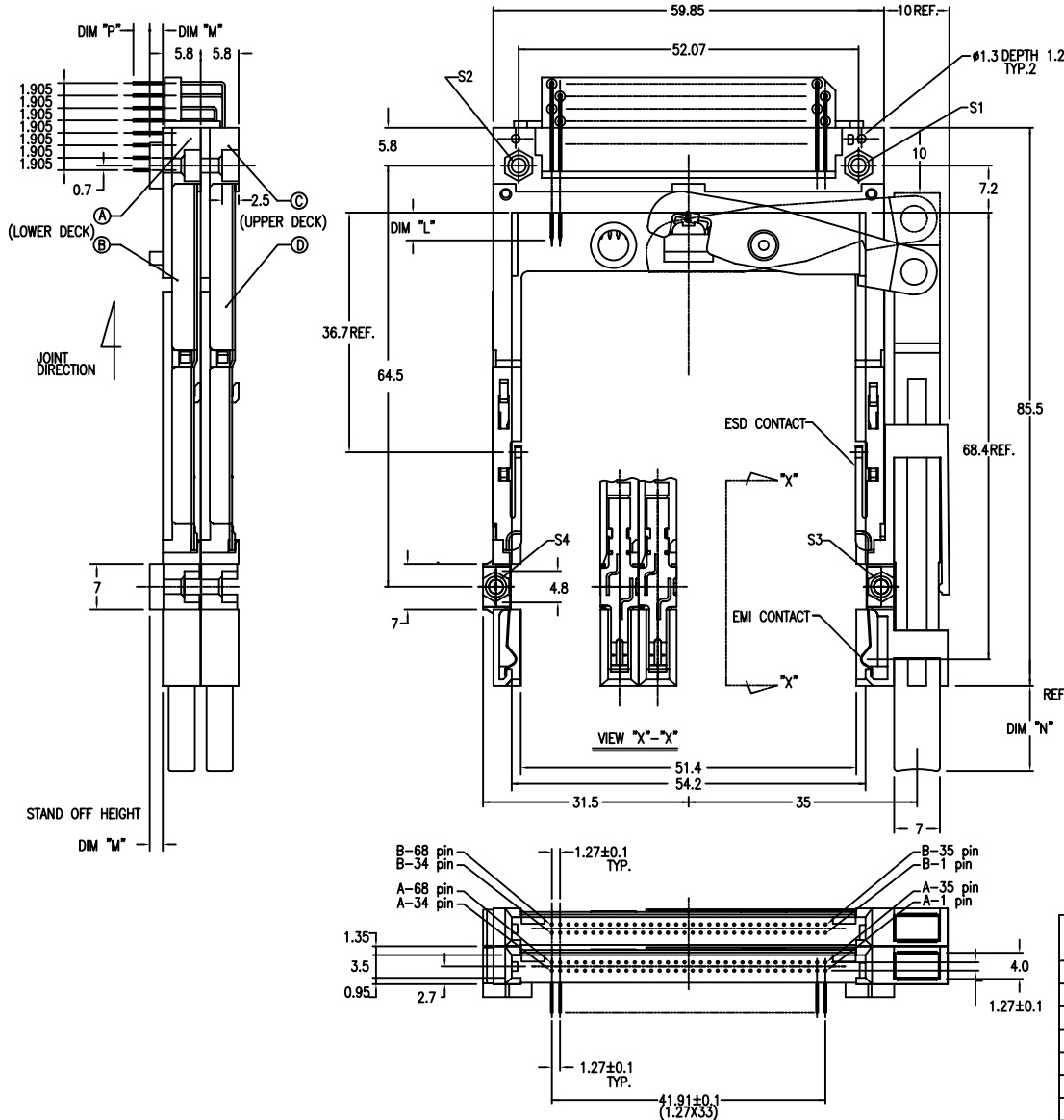

NOTE

- EJECT FORCE 3.5kg MAX.
- ASSY PROCESS  
2.1 TO MOUNT PART ④, ⑤ ON PWB WITH SCREW (S1,S2) AND SOLDER.  
2.2 TO JOINT PART ③, ⑥ INTO PART ④, ⑤ THEN FIX PART ③, ⑥ WITH 2 SCREWS (S3,S4).
- EJECT TRAVEL 8.0mm

④ MATERIAL

- PART ④, ⑤ (HEADER ASSY)  
PLASTIC : HIGH TEMPERATURE THERMOPLASTIC UL94V-0 BLACK  
PIN : COPPER ALLOY
- PART ③, ⑥ (EJECT MECHANISM ASSY)  
PLASTIC : HIGH TEMPERATURE THERMOPLASTIC UL94V-0 BLACK  
PLATE : STAINLESS  
EMI CONTACT : COPPER ALLOY

⑤ -1 FINISH (PIN)

UNDER PLATING : 0.5 μm MIN. Ni  
CONTACT AREA : 0.076 μm MIN. GOLD  
SOLDER TAIL : 2.5 μm MIN. Sn-Pb.

⑤ -2 FINISH (PIN) (FOR -\*\*\*\*LF)

UNDER PLATING : 0.5 μm MIN. Ni  
CONTACT AREA : 0.076 μm MIN. GOLD  
SOLDER TAIL : 2.5 μm MIN. Sn.

6. DIM "L"	4.25±0.1	3.5±0.1	5.0±0.1
PIN NUMBER	OTHERS	36.67	117.34 351.68

7. GENERAL TOLERANCE : ±0.3

8. SEE SHEET 1 REGARDING COMPONENTS

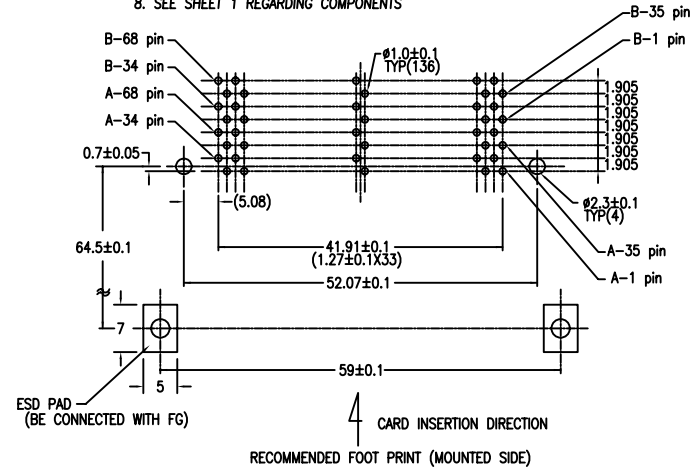

mat'l. code	surface	tolerance	projection	product family
	ISO1302	ISO1302 ISO1101		PCMCIA
ltr	ecn no	dr	date	title
K				68P DOUBLE EJECTOR HEADER ASSY FOR TYPE I/II/III
	angles			dwg no
	0°±x'	0.X±0.3	0.XX±0.13	sheet. 9 of 9
	dr	M.HASEGAWO	06/17/05	size
	engr	M.HASEGAWO	06/17/05	A4
	chr	M.HASEGAWO	06/20/05	
	appd	M.HASEGAWO	06/20/05	type
sheet	revision			Product Customer Drawing
index	sheet			