

P/N	PLATING OPTIONS	DIM C	DIM D	DIM E	WITHSTANDING MFG TEST
48336-1001	GOLD FLASH	7.10	5.35	7.90	NO
48336-1002	15 MICROINCH				NO
48336-1003	30 MICROINCH				YES
48336-2001	GOLD FLASH	7.60	5.85	8.40	NO
48336-2002	15 MICROINCH				NO
48336-2003	30 MICROINCH				YES

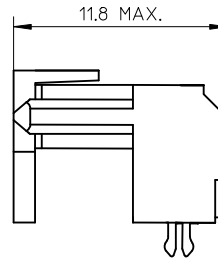
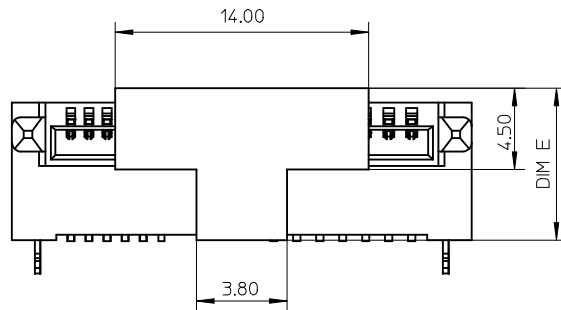
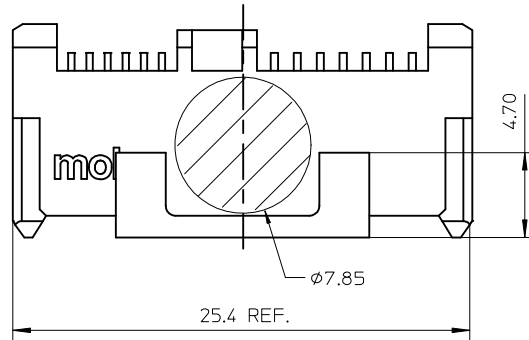

NOTES:

1.MATERIAL:

HOUSING :LIQUID CRYSTAL POLYMER,GLASS FIBER FILLED,

UL94V-0,COLOR:BLACK.

CAP: LIQUID CRYSTAL POLYMER,GLASS FIBER FILLED,

UL94V-0, COLOR:IVORY.

TERMINAL:COPPER ALLOY.

CLIP:COPPER ALLOY.

2.PLATING:

TERMINAL:

CONTACT AREA:SEE TABLE

SOLDER TAIL:MATTE TIN,THICKNESS=100 MICROINCH MIN/2.54 MICROMETER MIN.

UNDER PLATE:NICKEL(NI),THICKNESS=50 MICROINCH MIN/1.27 MICROMETER MIN.

CLIP:TIN(Sn),THICKNESS=100 MICROINCH MIN/2.54 MICROMETER MIN.

3. PICK & PLACE VACUUM AREA.

4.RECOMMENDED PCB THICKNESS:1.20±0.05mm

5.PRODUCT SPECIFICATION REFER TO PS-48321-001

6.TEST SUMMARY:

48336-1003 REFER TO TS-48336-103

48336-2003 REFER TO TS-48336-203

7.PACKAGING SPECIFICATION REFER TO PK-48336-001

8.LEAD FREE & RoHS COMPLIANT PRODUCT.

REVISE EC NO: SH2009-0783 DRW:NFYANG05 2009/07/21 CHK:DHHE 2009/07/22 APPR:RZHANG 2009/08/17	DESCRIPTION REV	QUALITY SYMBOLS =0 =0	GENERAL TOLERANCES (UNLESS SPECIFIED)		DIMENSION STYLE MM ONLY		SCALE 1:1	DESIGN UNITS METRIC	THIRD ANGLE PROJECTION	
			mm	INCH	DRAWN BY LINDA	DATE 2008/7/25	TITLE SLIMLINE SATA RECEPTACLE REVERSE SMT TYPE WITH CLIP			
		4 PLACES ± --- ± --- 3 PLACES ± 0.10 ± --- 2 PLACES ± 0.15 ± --- 1 PLACE ± 0.25 ± ---			CHECKED BY DMZHANG02	DATE 2008/7/31				
				ANGULAR ± 3 °		APPROVED BY HWWANG	DATE 2008/7/31	MOLEX INCORPORATED		
		DRAFT WHERE APPLICABLE MUST REMAIN WITHIN DIMENSIONS	SEE TABLE		MATERIAL NO. SD-48336-001	DOCUMENT NO.	SHEET NO. 2 OF 2			