

AEMD-LG3K, AEMD-LL3K

High Brightness Red and Amber SMT Oval Lamps

Description

The new Broadcom[®] series is essentially like a conventional high brightness through hole LED in the form of a surface mount device. It can be assembled using common SMT assembly processes and is compatible with the industrial reflow soldering process.

The LEDs are made with an advanced optical grade epoxy for superior performance in outdoor sign applications. For easy pick-and-place assembly, the LEDs are shipped in tape and reel. Every reel is shipped from a single intensity and color bin for better uniformity.

Features

- High brightness AlInGaP
- Available in Red and Amber
- Typical viewing angle: 95° × 45°
- Tinted and diffused appearance
- Surface mountable
- Compatible with industrial reflow soldering process
- MSL 3

Applications

- Gas price signs
- Monocolor signs
- Full color signs

CAUTION!

This LED is ESD sensitive. Please observe appropriate precautions during handling and processing. Refer to application note AN-1142 for additional details.

Keep the LED in a moisture barrier bag is < 5% RH when not in use because prolonged exposure to the environment might cause the leads to tarnish or rust, which might cause difficulties in soldering.

Figure 1: Package Drawing

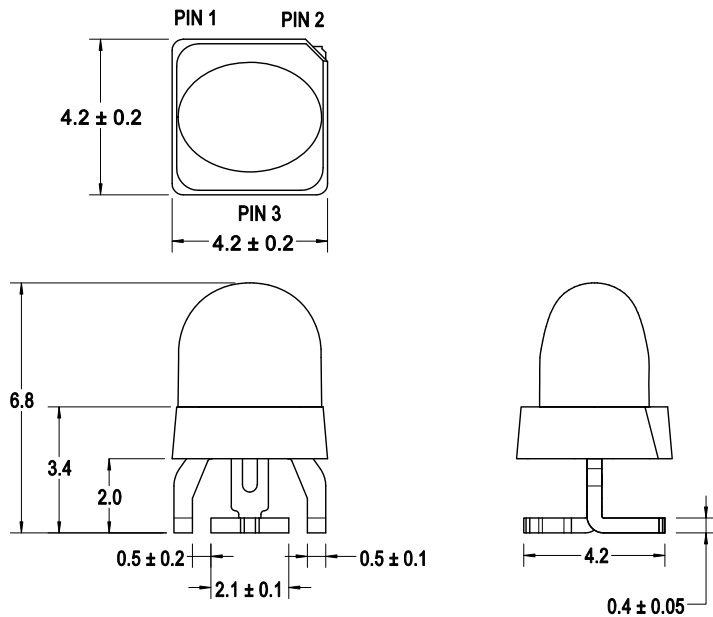

Lead Configuration	
Pin 1	Anode
Pin 2	Cathode
Pin 3	Anode

NOTE:

1. All dimensions in millimeters (mm).
2. Tolerance is ± 0.50 mm unless otherwise specified.

Device Selection Guide

$T_J = 25^\circ\text{C}$, $I_F = 20$ mA.

Part Number	Color	Luminous Intensity, I_V (mcd) ^{a, b}		Dominant Wavelength, λ_d (nm) ^c	
		Min.	Max.	Min.	Max.
AEMD-LG3K-XZ002	Red	1660	2900	618.0	630.0
AEMD-LG3K-XY002	Red	1660	2400	618.0	630.0
AEMD-LL3K-XZ002	Amber	1660	2900	584.5	594.5
AEMD-LL3K-XYK02	Amber	1660	2400	587.0	592.0
AEMD-LL3K-XYL02	Amber	1660	2400	589.5	594.5

- a. The luminous intensity, I_V is measured at the mechanical axis of the package and it is tested with a single current pulse condition. The actual peak of the spatial radiation pattern may not be aligned with the axis.
- b. Tolerance is $\pm 15\%$.
- c. The dominant wavelength, λ_d is derived from the CIE Chromaticity Diagram and represents the perceived color of the device.

Absolute Maximum Ratings

Parameters	Red/Amber	Units
DC Forward Current ^a	50	mA
Peak Forward Current ^b	100	mA
Power Dissipation	120	mW
Reverse Voltage	Not recommended for reverse bias	
LED Junction Temperature	110	°C
Operating Temperature Range	-40 to +85	°C
Storage Temperature Range	-40 to +100	°C

a. Derate linearly as shown in [Figure 9](#).

b. Duty factor = 30%, frequency = 1 kHz.

Optical and Electrical Characteristics

$T_J = 25^\circ\text{C}$.

Parameters	Min.	Typ.	Max.	Units	Test Condition
Viewing Angle, $2\theta_{1/2}$ ^a	—	95 × 45	—	°	$I_F = 20\text{ mA}$
Dominant Wavelength, λ_d ^b				nm	$I_F = 20\text{ mA}$
Red	618.0	621.0	630.0		
Amber	584.5	590.0	594.5		
Peak Wavelength, λ_p				nm	$I_F = 20\text{ mA}$
Red	—	630	—		
Amber	—	594	—		
Forward Voltage, V_F ^c				V	$I_F = 20\text{ mA}$
Red	1.8	2.1	2.4		
Amber	1.8	2.1	2.4		
Reverse Voltage, V_R ^d				V	$I_R = 100\ \mu\text{A}$
Red	5	—	—		
Amber	5	—	—		
Thermal Resistance, $R\theta_{J-P}$ ^e				°C/W	LED junction to pin
Red	—	270	—		
Amber	—	270	—		

a. $\theta_{1/2}$ is the off-axis angle where the luminous intensity is $1/2$ the peak intensity.

b. The dominant wavelength, λ_d is derived from the CIE Chromaticity Diagram and represents the perceived color of the device.

c. Forward voltage tolerance is $\pm 0.1\text{V}$.

d. Indicates product final test condition. Long-term reverse bias is not recommended.

e. Thermal resistance from LED junction to pin.

Part Numbering System

A E M D -

x ₁	x ₂	x ₃
----------------	----------------	----------------

 K -

x ₄	x ₅	x ₆	x ₇	x ₈
----------------	----------------	----------------	----------------	----------------

Code	Description	Option	
x ₁	Package Type	L	Oval AllnGaP
x ₂	Color	G	Red
		L	Amber
x ₃	Viewing Angle	3	95° × 45°
x ₄	Minimum Intensity Bin	Refer to Intensity Bin Limits (CAT) table	
x ₅	Maximum Intensity Bin		
x ₆	Color Bin Option	0	Full distribution
		K	Color bins 2 and 4
		L	Color bins 4 and 6
x ₇ x ₈	Packaging Option	02	Tested at 20 mA

Part Number Example

AEMD-LL3K-XYK02

x₁ : L – Oval AllnGaP
 x₂ : L – Amber color
 x₃ : 3 – 95° × 45° viewing angle
 x₄ : X – Minimum intensity bin X
 x₅ : Y – Maximum intensity bin Y
 x₆ : K – Color bins 2 and 4
 x₇ x₈ : 02 – Tested at 20 mA

Bin Information

Intensity Bin Limits (CAT)

Bin ID	Luminous Intensity, I_v (mcd)	
	Min.	Max.
X	1660	1990
Y	1990	2400
Z	2400	2900

Tolerance = $\pm 15\%$

Forward Voltage Bin Limits (VF)

Bin ID	Forward Voltage, V_F (V)	
	Min.	Max.
VD	1.8	2.0
VA	2.0	2.2
VB	2.2	2.4

Tolerance = $\pm 0.1V$

Color Bin Limits (BIN)

Bin ID	Dominant Wavelength, λ_d (nm)	
	Min.	Max.
Red		
—	618.0	630.0
Amber		
1	584.5	587.0
2	587.0	589.5
4	589.5	592.0
6	592.0	594.5

Tolerance = ± 1.0 nm

Example of bin information on reel and packaging label:

CAT : Y – Intensity bin Y
 BIN : 2 – Color bin 2
 VF : VA – Forward voltage bin VA

Figure 2: Spectral Power Distribution

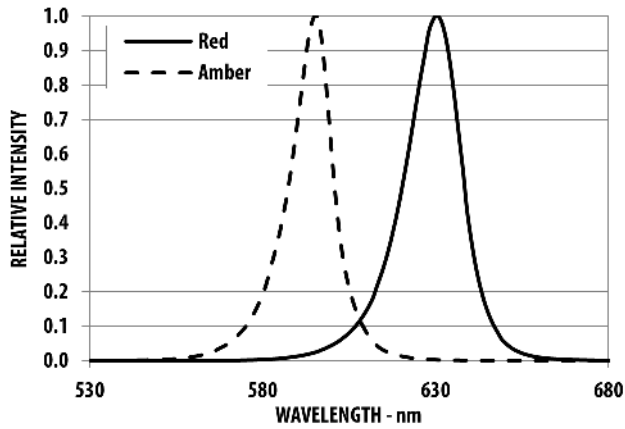

Figure 3: Forward Current vs. Forward Voltage

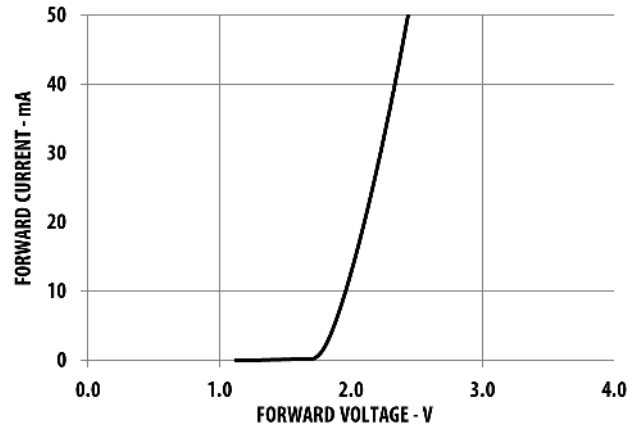

Figure 4: Relative Luminous Intensity vs. Mono Pulse Current

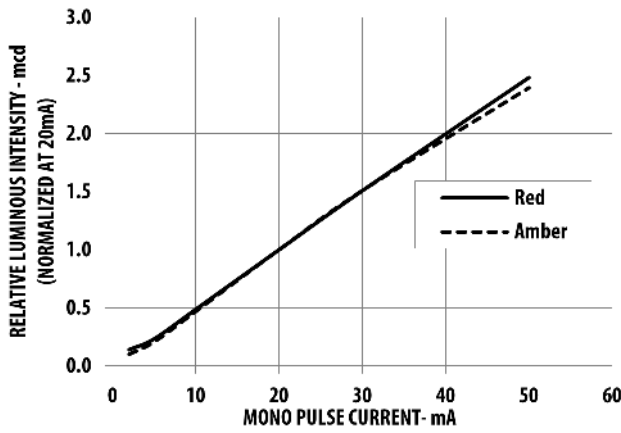

Figure 5: Dominant Wavelength Shift vs. Mono Pulse Current

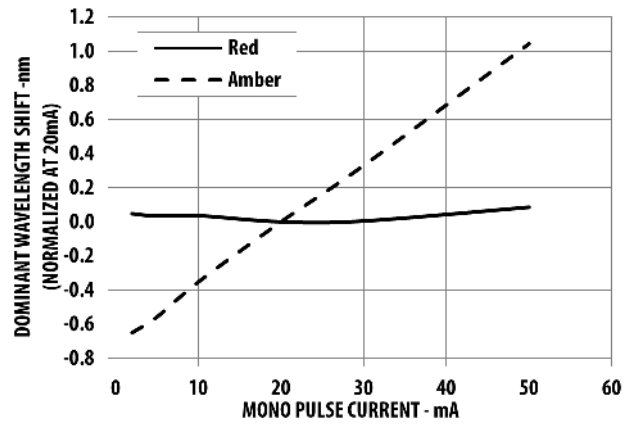

Figure 6: Relative Light Output vs. Junction Temperature

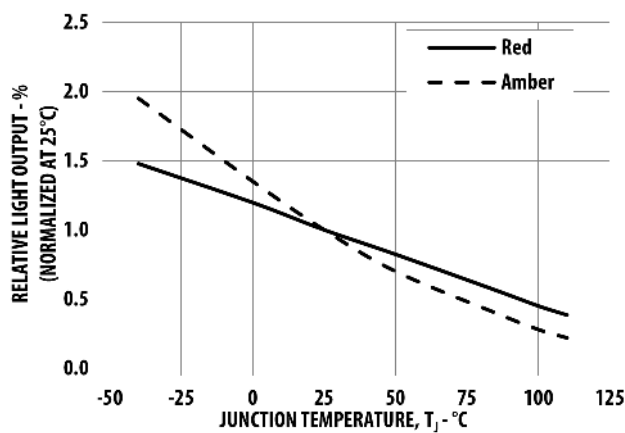

Figure 7: Forward Voltage Shift vs. Junction Temperature

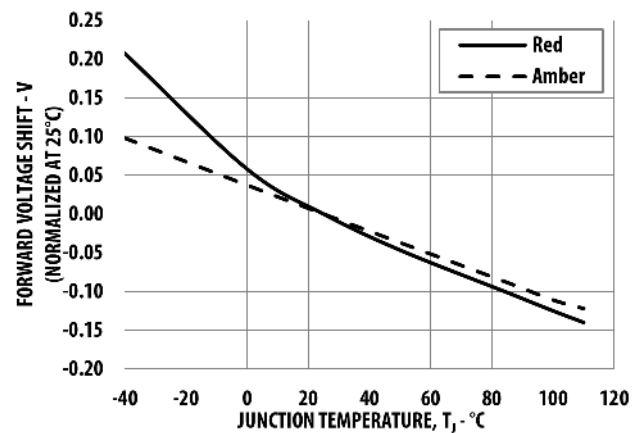

Figure 8: Radiation Pattern

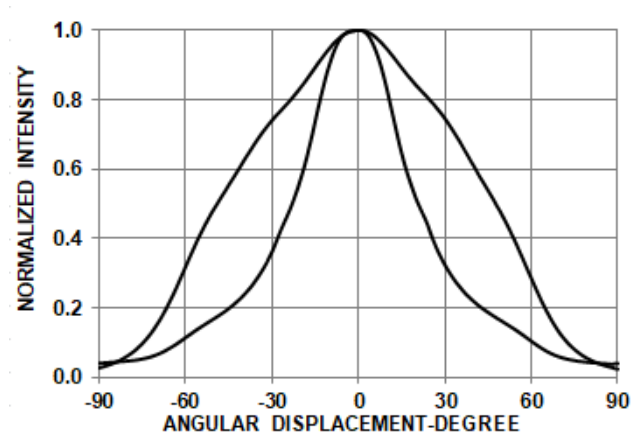

Figure 9: Maximum Forward Current vs. Ambient Temperature. Derated based on $T_{JMAX} = 110^{\circ}C$

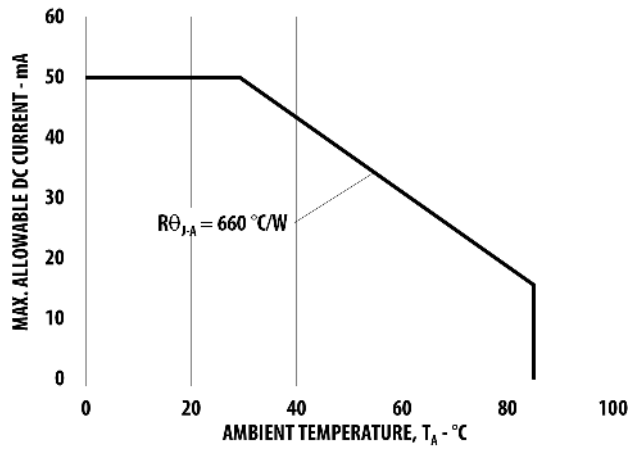
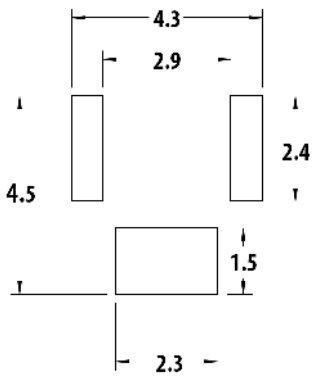

Figure 10: Recommended Soldering Land Pattern



NOTE:

1. All dimensions are in millimeters (mm).
2. Recommended stencil thickness is 0.1524 mm (6 mil) minimum and above.

Figure 11: Carrier Tape Dimensions

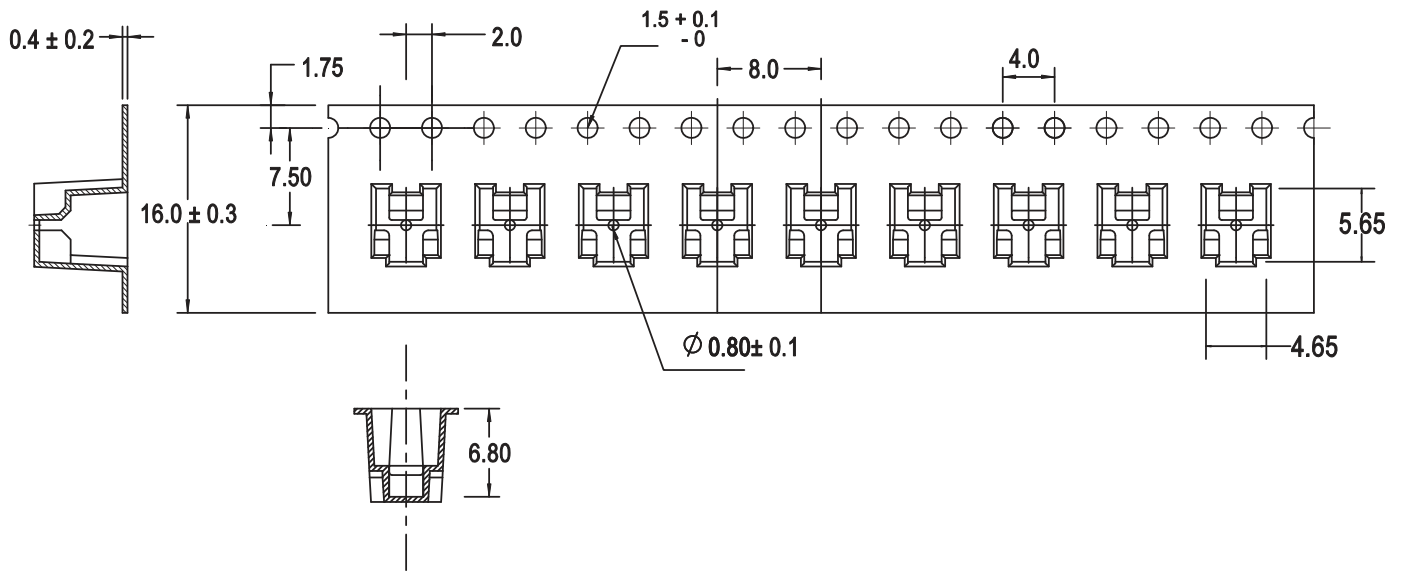

NOTE:

1. All dimensions in millimeters (mm).
2. Tolerance is ± 0.10 mm unless otherwise specified.

Figure 12: Reel Dimensions

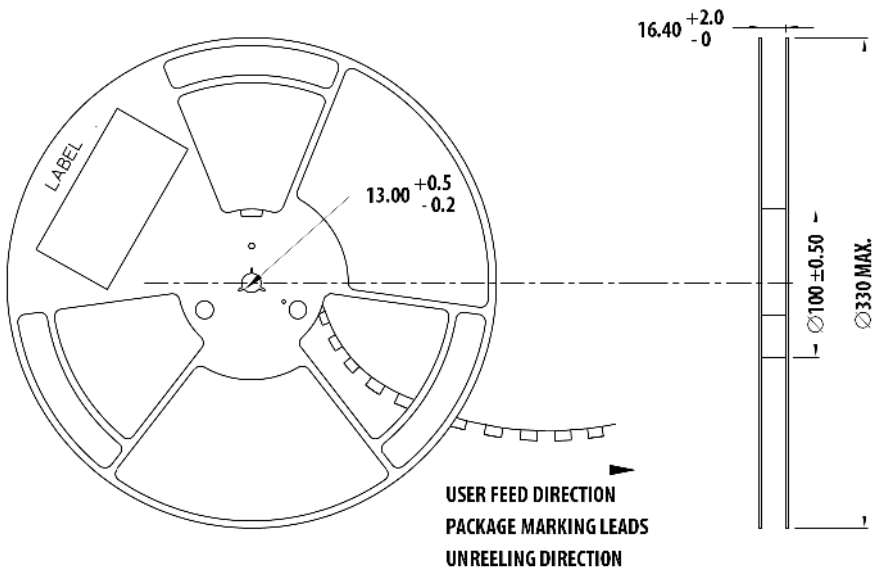

NOTE: All dimensions are in millimeters (mm).

Precautionary Notes

Soldering

- Do not perform reflow soldering more than twice. Observe necessary precautions of handling moisture-sensitive devices as stated in the following section.
- Do not apply any pressure or force on the LED during reflow and after reflow when the LED is still hot.
- Use reflow soldering to solder the LED. Use hand soldering only for rework if unavoidable, but it must be strictly controlled to following conditions:
 - Soldering iron tip temperature = 315°C maximum
 - Soldering duration = 3 seconds maximum.
 - Number of cycles = 1 only.
 - Power of soldering iron = 50W maximum.
- Do not touch the LED package body with the soldering iron except for the soldering terminals, as it may cause damage to the LED.
- Confirm beforehand whether the functionality and performance of the LED is affected by soldering with hand soldering.

Figure 13: Recommended Lead-Free Reflow Soldering Profile

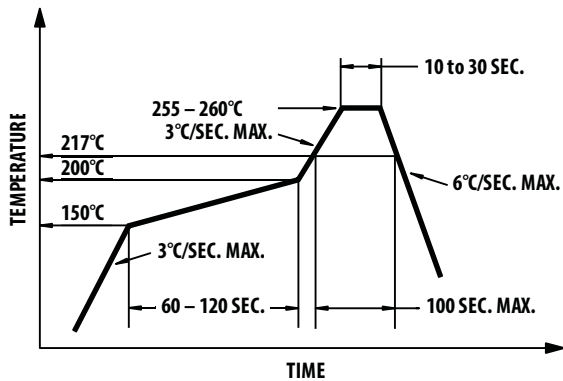

Handling Precautions

For automated pick-and-place, Broadcom has tested the following nozzle size to work well with this LED. However, due to the possibility of variations in other parameters, such as pick-and-place machine maker/model, and other settings of the machine, verify that the selected nozzle performs as per requirements.

Figure 14: Recommended Nozzle Dimension

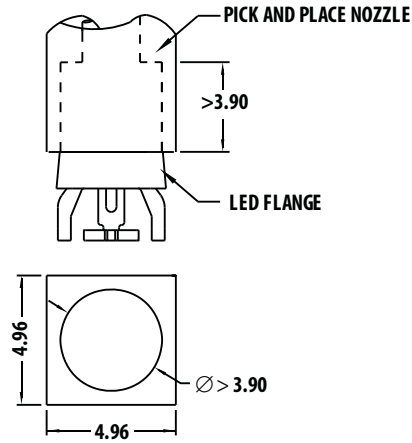

NOTE:

1. The nozzle tip must touch the LED flange during pick and place.
2. The outer dimensions of the nozzle tip must be able to fit into the carrier tape pocket until it touches the LED flange.
3. All dimensions are in millimeters (mm).

Handling of Moisture-Sensitive Devices

This product has a Moisture Sensitive Level 3 rating per JEDEC J-STD-020. Refer to Broadcom Application Note AN5305, *Handling of Moisture Sensitive Surface Mount Devices*, for additional details and a review of proper handling procedures.

Before use:

- An unopened moisture barrier bag (MBB) can be stored at < 40°C/90% RH for 12 months. If the actual shelf life has exceeded 12 months and the humidity indicator card (HIC) indicates that baking is not required, it is safe to reflow the LEDs per the original MSL rating.
- Do not open the MBB prior to assembly (for example, for IQC). If unavoidable, the MBB must be properly resealed with fresh desiccant and HIC. The exposed duration must be taken in as floor life.

Control after opening the MBB:

- Read the HIC immediately upon opening of MBB.
- Keep the LEDs at < 30°/60% RH at all times, and complete all high temperature-related processes, including soldering, curing or rework within 168 hours.

Control for unfinished reel:

Store unused LEDs in a sealed MBB with desiccant or a desiccator at < 5% RH.

Control of assembled boards:

If the PCB soldered with the LEDs is to be subjected to other high-temperature processes, store the PCB in a sealed MBB with desiccant or desiccator at < 5% RH to ensure that all LEDs have not exceeded their floor life of 168 hours.

Baking is required if the following conditions exist:

- The HIC indicates a change in color for 10% and 5%, as stated on the HIC.
- The LEDs are exposed to conditions of > 30°C/60% RH at any time.
- The LED's floor life exceeded 168 hours.

The recommended baking condition is: 60°C ± 5°C for 20 hours.

Baking can only be done once.

Storage:

The soldering terminals of these Broadcom LEDs are silver plated. If the LEDs are exposed in an ambient environment for too long, the silver plating might be oxidized, thus affecting its solderability performance. Therefore, keep unused LEDs in a sealed MBB with desiccant or in a desiccator at < 5% RH.

Application Precautions

- The drive current of the LED must not exceed the maximum allowable limit across temperature as stated in the data sheet. Constant current driving is recommended to ensure consistent performance.
- Circuit design must cater to the whole range of forward voltage (V_F) of the LEDs to ensure the intended drive current can always be achieved.

- The LED exhibits slightly different characteristics at different drive currents, which may result in a larger variation of performance (such as intensity, wavelength, and forward voltage). Set the application current as close as possible to the test current to minimize these variations.
- The LED is not intended for reverse bias. Use other appropriate components for such purposes. When driving the LED in matrix form, ensure that the reverse bias voltage does not exceed the allowable limit of the LED.
- As the actual application might not be exactly similar to the test conditions, verify that the LED will not be damaged by prolonged exposure in the intended environment.
- Avoid rapid changes in ambient temperatures, especially in high-humidity environments, because they cause condensation on the LED.
- If the LED is intended to be used in a harsh or an outdoor environment, protect the LED against damage caused by rain water, water, dust, oil, corrosive gases, external mechanical stresses, and so on.
- The number of reflow cycles and reflow temperature condition used may affect optical characteristics of the LED. Use LEDs with the same number of reflow cycle and same reflow temperature condition within the same finished good.

Thermal Management

The optical, electrical, and reliability characteristics of the LED are affected by temperature. Keep the junction temperature (T_J) of the LED below the allowable limit at all times. T_J can be calculated as follows:

$$T_J = T_A + R_{\theta J-A} \times I_F \times V_{Fmax}$$

where:

T_A = Ambient temperature (°C)

$R_{\theta J-A}$ = Thermal resistance from LED junction to ambient (°C/W)

I_F = Forward current (A)

V_{Fmax} = Maximum forward voltage (V)

The complication of using this formula lies in T_A and $R_{\theta J-A}$. Actual T_A is sometimes subjective and hard to determine. $R_{\theta J-A}$ varies from system to system depending on design and is usually not known.

Another way of calculating T_J is by using the solder point temperature, T_S as follows:

$$T_J = T_S + R_{\theta J-S} \times I_F \times V_{Fmax}$$

where:

T_S = LED solder point temperature as shown in the following figure ($^{\circ}\text{C}$)

$R_{\theta J-S}$ = Thermal resistance from junction to solder point ($^{\circ}\text{C}/\text{W}$)

I_F = Forward current (A)

V_{Fmax} = Maximum forward voltage (V)

Figure 15: Solder Point Temperature on PCB

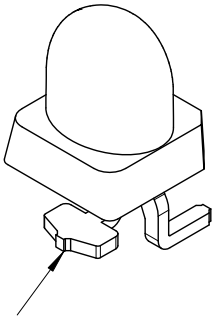

Ts Point

T_S can be easily measured by mounting a thermocouple on the soldering joint as shown in preceding figure, while $R_{\theta J-S}$ is provided in the data sheet. Verify the T_S of the LED in the final product to ensure that the LEDs are operating within all maximum ratings stated in the data sheet.

Eye Safety Precautions

LEDs may pose optical hazards when in operation. Do not look directly at operating LEDs because it might be harmful to the eyes. For safety reasons, use appropriate shielding or personal protective equipment.

Disclaimer

Broadcom's products and software are not specifically designed, manufactured, or authorized for sale as parts, components, or assemblies for the planning, construction, maintenance, or direct operation of a nuclear facility or for use in medical devices or applications. The customer is solely responsible, and waives all rights to make claims against Broadcom or its suppliers, for all loss, damage, expense, or liability in connection with such use.

Broadcom, the pulse logo, Connecting everything, Avago Technologies, Avago, and the A logo are among the trademarks of Broadcom and/or its affiliates in the United States, certain other countries, and/or the EU.

Copyright © 2018–2021 Broadcom. All Rights Reserved.

The term “Broadcom” refers to Broadcom Limited and/or its subsidiaries. For more information, please visit www.broadcom.com.

Broadcom reserves the right to make changes without further notice to any products or data herein to improve reliability, function, or design. Information furnished by Broadcom is believed to be accurate and reliable. However, Broadcom does not assume any liability arising out of the application or use of this information, nor the application or use of any product or circuit described herein, neither does it convey any license under its patent rights nor the rights of others.

