



qBoxMini AFC DIY IOT Enclosure Kits

User Manual

Abstract

User Manual describing the qBoxMini AFC DIY IOT Enclosure Kits. Kits features, content and project ideas provided.

IBT-QBM-AFC-X-UM

www.iot-bots.com





Table of Contents

Revision History	2
Overview.....	3
Features.....	3
Description	3
qBoxMini AFC Enclosure Kit (No SMA)	4
qBoxMini AFC Enclosure Kit (One SMA)	5
qBoxMini AFC Enclosure Kit (Two SMAs)	6
qBoxMini AFC Enclosure Kit parts	7
Specification	13
Enclosure Kit content.....	13
Project ideas	14
Abbreviations.....	15
Trademark notice.....	15
Ordering info	15



Revision History

NoNo	Version	Date	Author	Description
1	1.0	11.29.2020	lotbotscom	Initial
2				
3				



Overview

Perfect for any DIY IOT project, qBoxMini AFC Enclosure Kit product lines are the part of the newest HW platform designed to help hobbyists, makers and all DIYers to build environmental ready IOT solutions.

Features

- Flanged IP65 waterproof enclosure: Sealed, made of high-quality ABS material suitable for indoor and outdoor DIY IOT projects;
- Incorporated M8 cable glands: Two cable inputs securely allow bringing the power in and connecting sensors and actuators;
- Perfect fit PCB: High-quality double-sided PCB with 0.1" hole spacing for DIP integrated circuits, modules, and main controller board;
- Dedicated placement for controller board: Well-designed PCB allows to carry Adafruit Feather Compatible MCU board;
- Built in SMA connectors: Up to two SMA Straight Female to IPEX (u.FL) adapter cables give external antennas connections to your wireless board;
- Rich connectors set installed: Two terminal blocks, Grove, 4-pin JST and 0.1" AFC compatible interface connectors.

Description

qBoxMini AFC Enclosure Kits are part of qBoxMini AxC Enclosure Kits line. qBoxMini AxC Enclosure Kits line is based on qBoxMini Enclosure Kits product line and developed especially to be used with AFC or AMC boards. So, each kit PCB has dedicated connectors main CPU board could be plugged in (AFC or AMC).

Each qBoxMini AFC Enclosure Kit consists of durable waterproof IP65 enclosure with installed M8 glands, double sided PCB with connectors installed, integrated SMA to u.FL adapter cable (up to two, depending on kit model) and terminal block plugs set.

qBoxMini AFC Enclosure Kit (No SMA)

qBoxMini AFC Enclosure Kit (No SMA) is the simplest member in qBoxMini AFC Enclosure Kit family. It has no integrated SMA to u.FL adapter cable, but still able to keep wireless connectivity device with internal antennas.



Pic.1. qBoxMini AFC Enclosure Kit (No SMA) common view

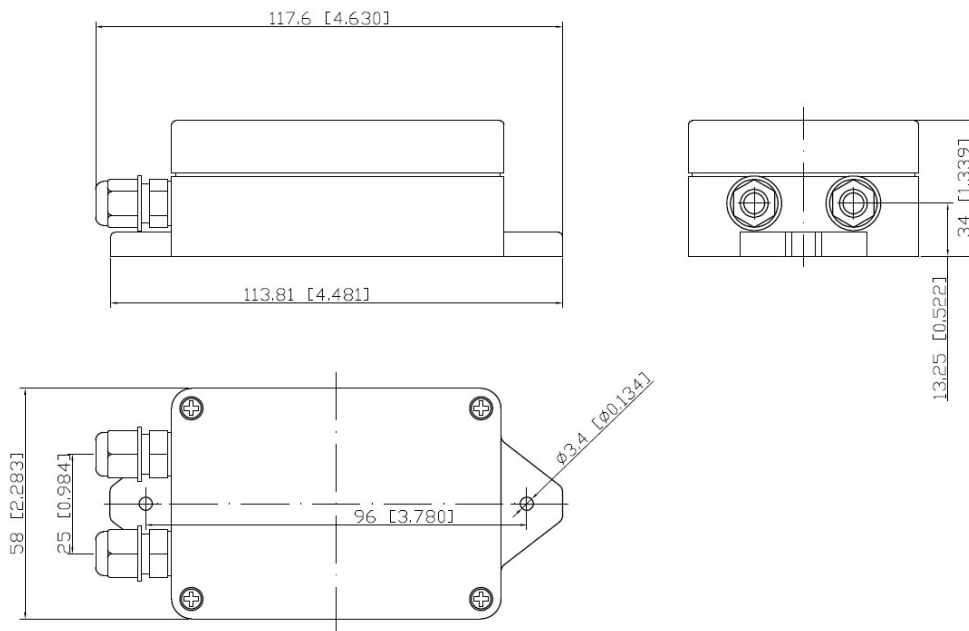

Pic. 2. qBoxMini AFC Enclosure Kit (No SMA) dimensions

qBoxMini AFC Enclosure Kit (One SMA)

qBoxMini AFC Enclosure Kit (One SMA) is the member of qBoxMini AFC Enclosure Kit family which is able to bring up to one external antenna signal to IOT device located inside. It has one integrated SMA to u.FL adapter cable.



Pic.3. qBoxMini AFC Enclosure Kit (One SMA) common view

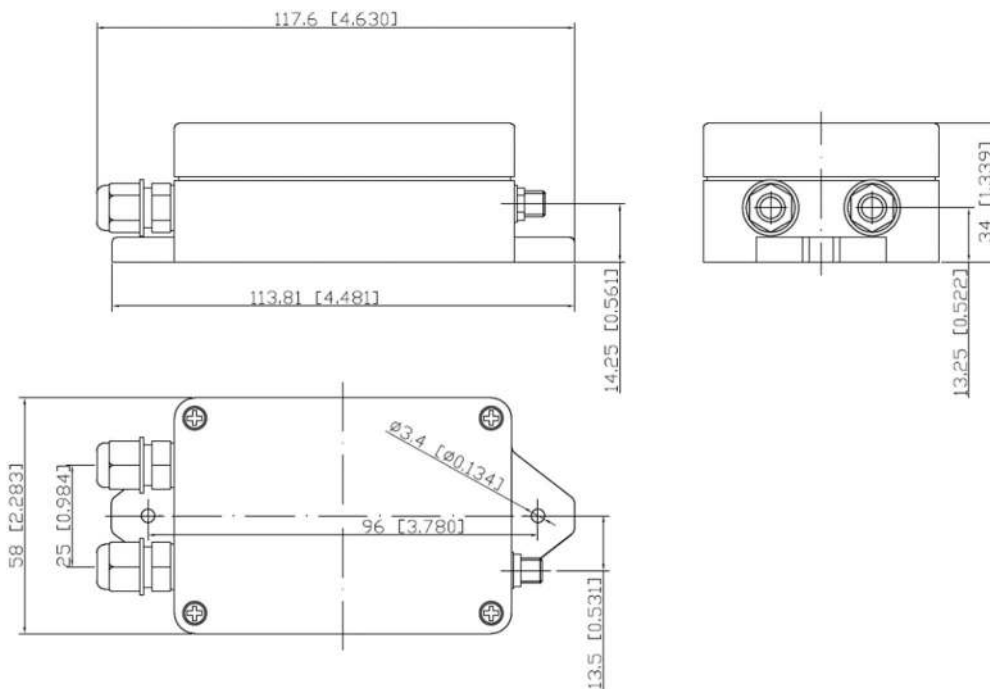

Pic. 4. qBoxMini AFC Enclosure Kit (One SMA) dimensions

qBoxMini AFC Enclosure Kit (Two SMAs)

qBoxMini AFC Enclosure Kit (Two SMA) is the most charged member of qBoxMini AFC Enclosure Kit family which has got two integrated SMA to u.FL adapter cables.



Pic.5. qBoxMini AFC Enclosure Kit (Two SMAs) common view

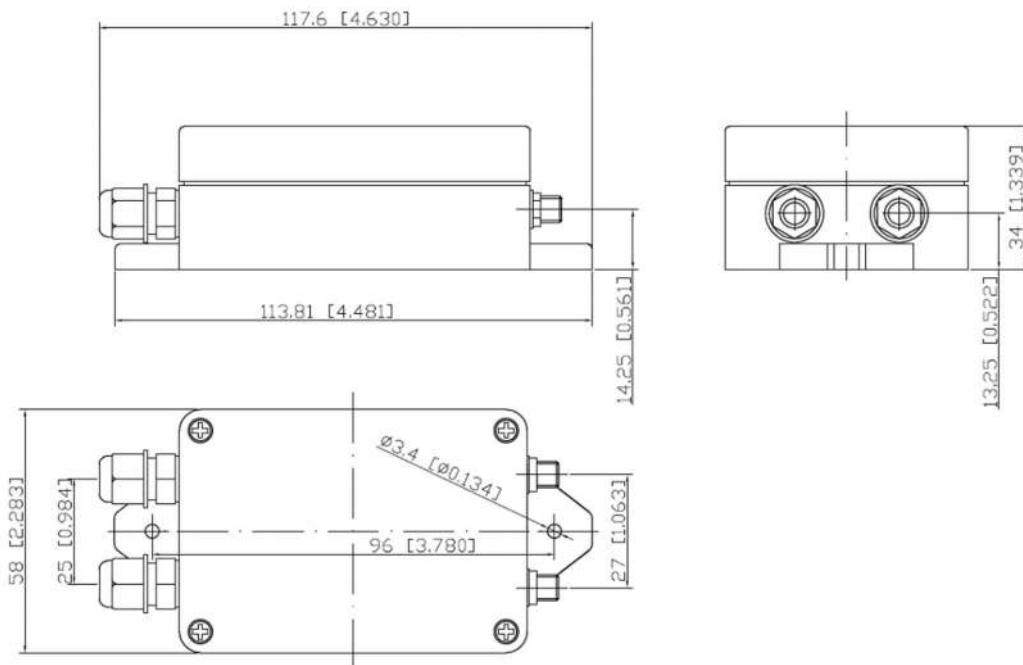

Pic. 6. qBoxMini AFC Enclosure Kit (Two SMAs) dimensions

qBoxMini AFC Enclosure Kit parts

Each qBoxMini AFC Enclosure Kit has got several parts built in.

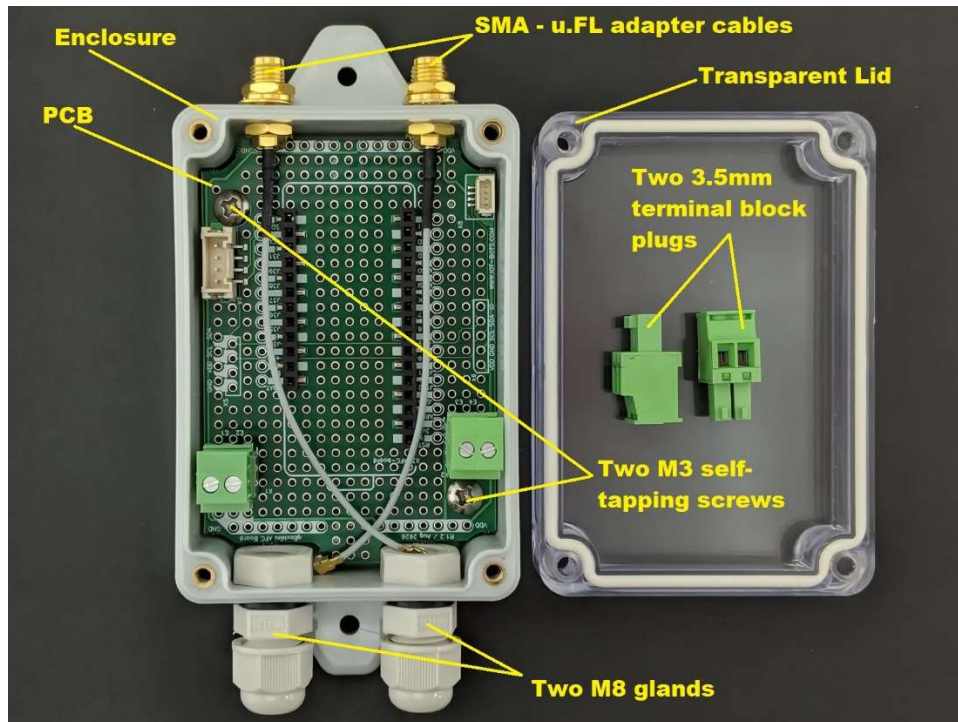

Pic.7. qBoxMini AFC Enclosure Kit parts

External DC voltage from power adapter or solar system could be brought by cable through the one gland inner and another gland gives opportunity to connect external sensors or actuators.

Up to two (depending on kit type) GSM / LTE / WiFi / LoRa / etc. external antennas could be connected to wireless board u.FL PCB connector via SMA to IPEX (u.FL) adapter cables glued into enclosure wall.

Two M3 self-tapping screws securely attach the PCB to the enclosure. Same time board could be easily removed.

Enclosure has enough room to keep with or without stacking header one IOT controller board like Adafruit Feather Compatible (AFC), power supply (DC/DC), OLED display and sensor modules using plain grid of proto holes.



Pic.8. qBoxMini AFC Enclosure Kit with Adafruit Feather Compatible board installed



Pic.9. qBoxMini AMC Enclosure Kit with Arduino MKR Compatible board installed

Each board has got two 3,5mm terminal blocks, one Grove, one 4-pin JST and two low profile pass through 0,1" SMT AFC interface compatible connectors installed. Additional two DIP 0.1" I2C interface connectors could be populated.

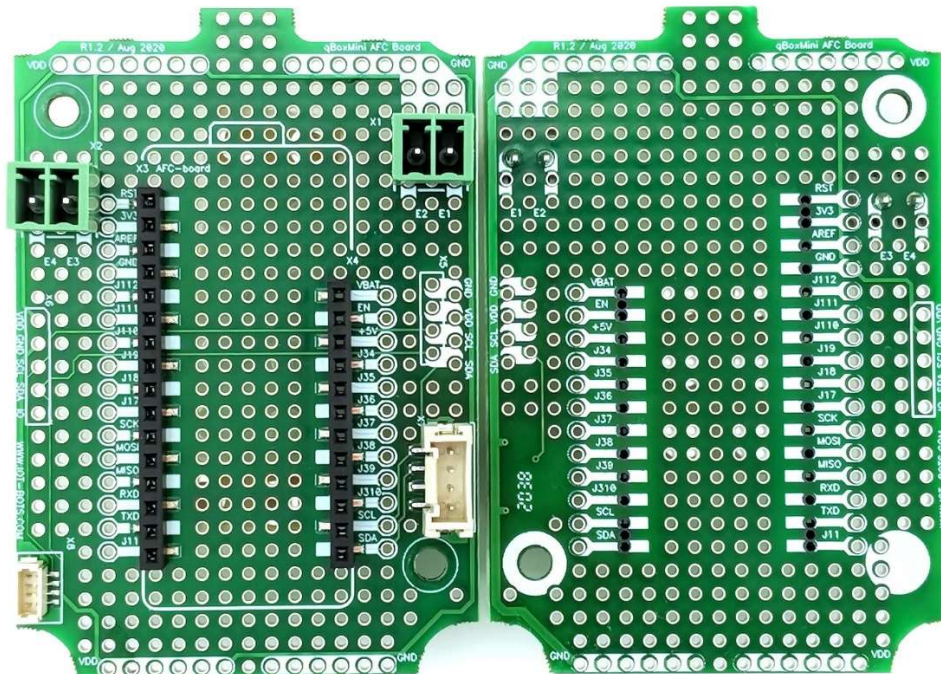

Pic.10. qBoxMini AFC Enclosure Kit PCB common view (Front and Back)

Each AFC connector pin has got a trace with DIP contacts that wires from other modules could be easily soldering.

Connector list:

- X1: External power connection through pluggable 3,5mm terminal block;
- X2: External Input / Output sensor / actuator connections through pluggable 3,5mm terminal block;
- X3, X4: IOT board connectors (low profile 0,1" pass through SMT receptacle);
- X5: OLED I2C connector placement (0,1" DIP) with pins: VDD, GND, SCL, SDA;
- X6: I2C sensors connector placement (0,1" DIP) with pins: VDD, GND, SCL, SDA, IO;
- X7: 4 pins Grove compatible I2C&Power connector (2,0 mm SMT) with pins: VDD, GND, SCL, SDA;
- X8: 4 pins JST I2C&Power connector (2,0 mm SMT) with pins: VDD, GND, SCL, SDA.

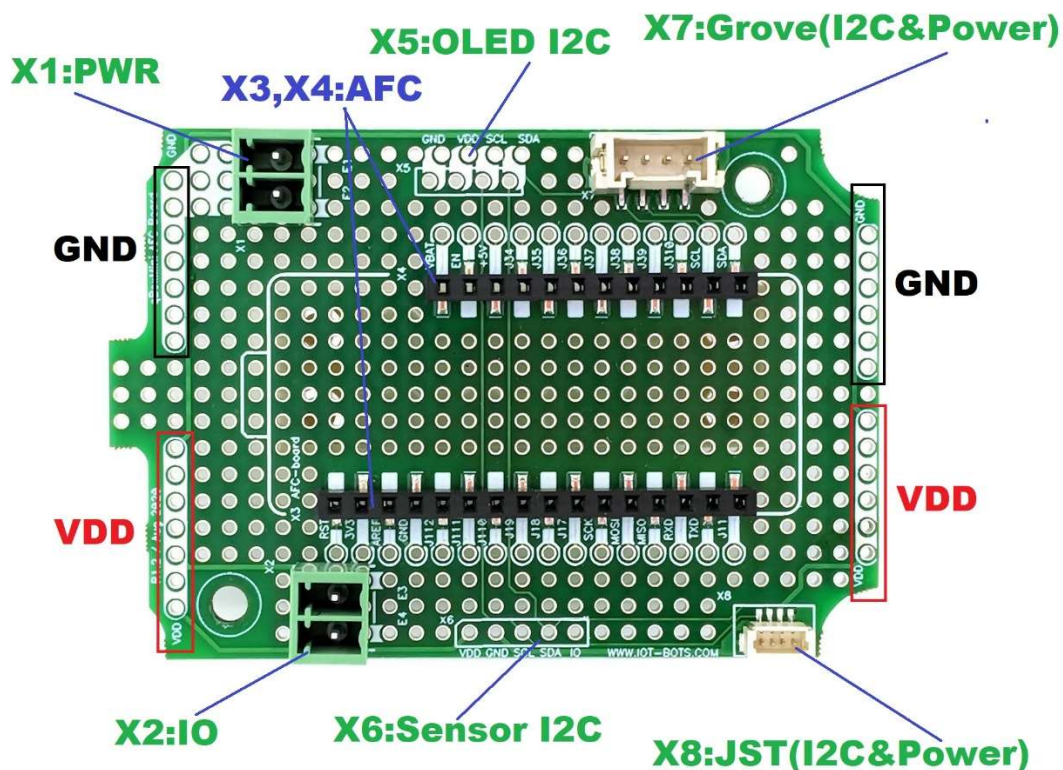

Pic.11. qBoxMini AFC PCB Connectors

There are VDD, GND and I2C connections between appropriate connectors pins and CPU board, so no needs to make these connections separately, just plug a CPU board and I2C sensors to Grove or JST connectors and get solution working. Two separate power traces for VDD and GND along short PCB sides allow bring the power to sensor boards.

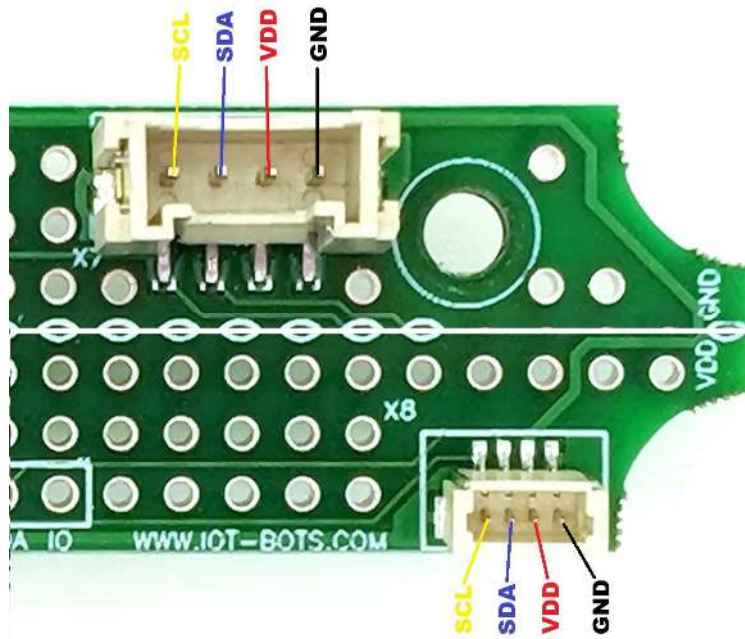

Pic.12. qBoxMini AFC JST and Grove connectors pinout

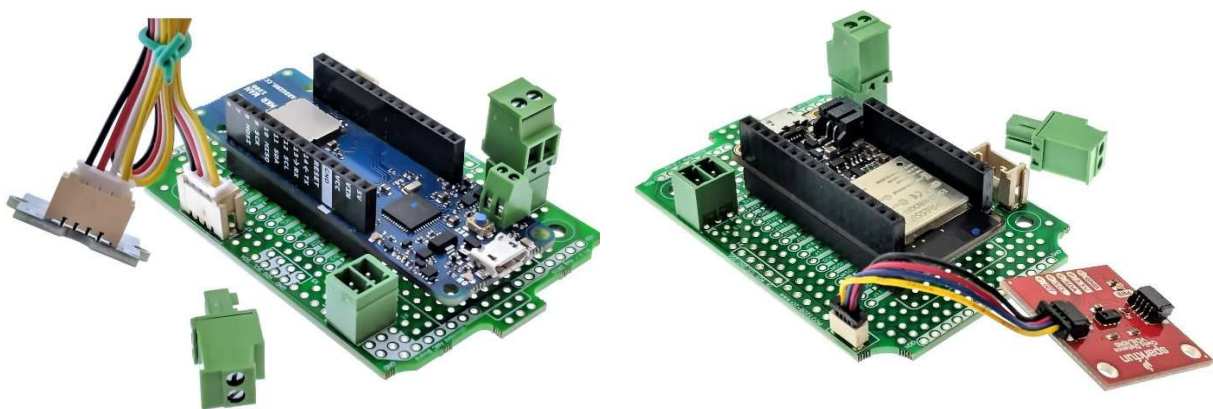

Pic.13. Grove and JST sensors board connection examples

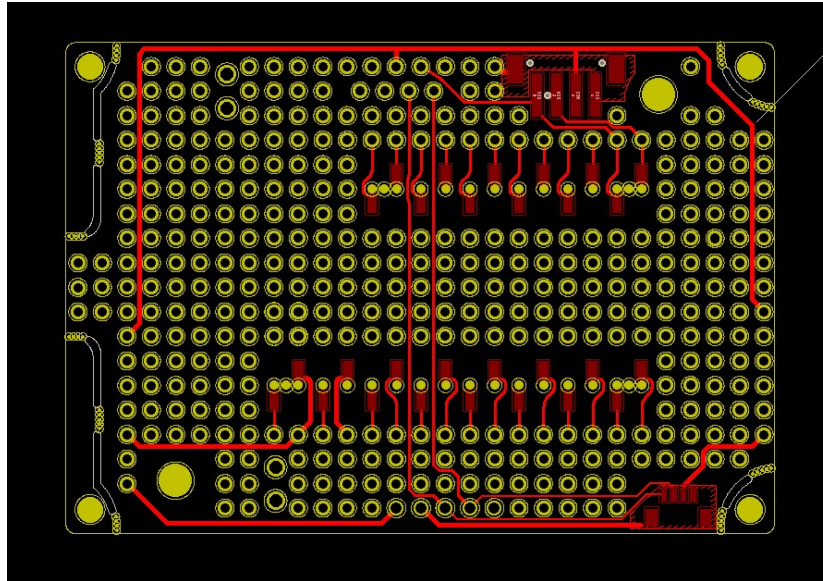

Pic.14. AFC PCB Front Copper traces

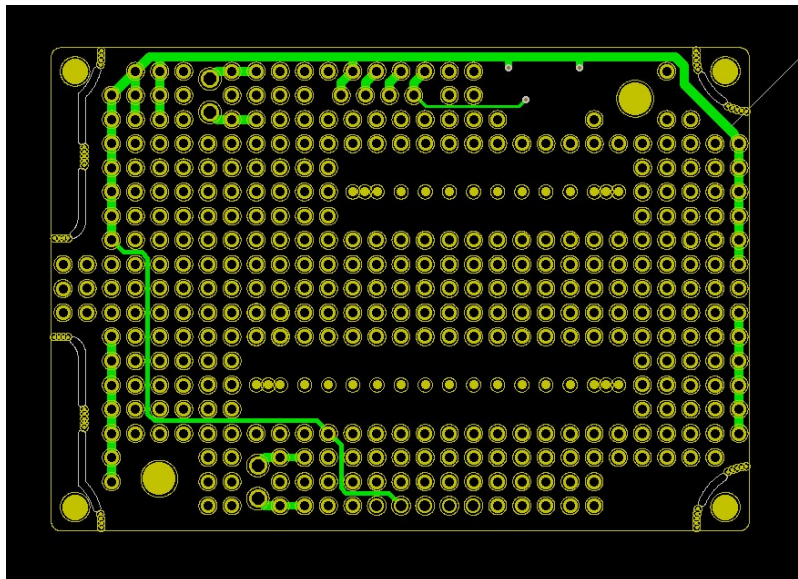

Pic.15. AFC PCB Back Copper traces

IOT board connector pins have power and main interfaces names printed out on PCB. The rest of the pins have conditional names as Jxx.

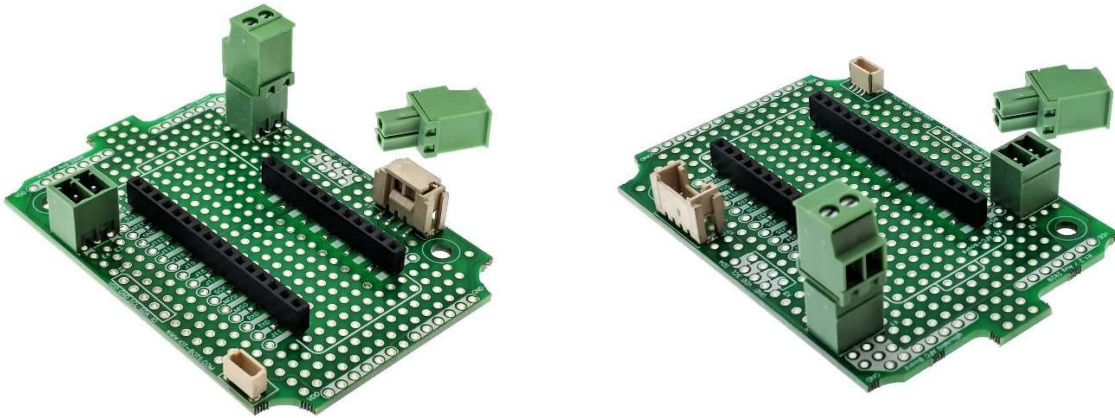

Pic.16. qBoxMini AFC Enclosure Kit PCB

Low profile 0,1" pass through SMT connectors allow to carry Controller board as closer as possible to Kit PCB, saving space above that board to place additional components, like battery, OLED or sensors.

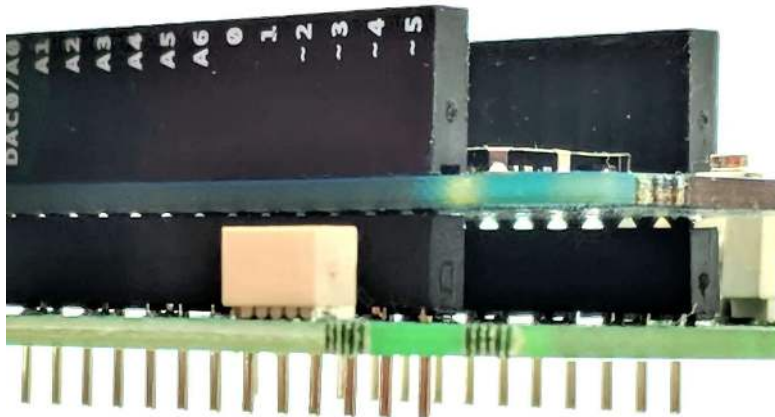

Pic.17. Low profile 0,1" pass through SMT connectors

Transparent lid allows to see internal parts, electronics, LEDs and even display and is able to hold LiPol battery to be applied to the internal surface.



Pic. 18. LiPol battery applied to a transparent lid (assembled view)



Pic. 19. LiPol battery applied to a transparent lid (inside view)

Specification

Housing Material: ABS

Water and Dust Proof: IP65

Enclosure Outer Size: 4.63"x2.28"x1.34" (L*W*H)

Enclosure Inner Size: 3.0"x2.0"x1.1" (L*W*H)

Gland model: M8

Cables with diameters: 0.08-0.19"

PCB size: 2.9"x2.0"

SMA u.FL adapter cables : up to 2

SMA u.FL adapter cable length : 3.15"

Enclosure Kit content

- IP65 waterproof enclosure with two M8 glands installed and up to two SMA u.FL adapter cables glued (depending on kit type);
- High quality prototyping double sided PCB mounted with two M3 self-tapping screws and connectors installed:

- Adafruit Feather Compatible board female headers set (low profile pass through 0,1" pitch 1x12 and 1x16 pins connectors);
- Two 3,5mm 2 pins terminal blocks;
- Grove 2mm connector;
- 4-pin JST I2C&Power connector;
- Two 3,5mm 2 pins terminal plugs;
- Packaging bag and shipping box.

Project ideas

Using qBoxMini AFC Enclosure Kits the variety of IOT DIY and POC projects could be done, like LoRa-based soil moisture monitoring project, home WiFi garage door opener, NB-IOT beehive monitoring system, GSM GPS asset tracking solution and many others.



Pic. 20. LTE BT / BLE IOT controller



Pic. 21. WiFi ESP32 No SMA project



Pic. 22. WiFi Ultrasound sensor : waste collection project



Pic. 23. LTE CAT-M1 WiFi GPS asset tracker POC

Abbreviations

NoNo	Abbreviation	Explanation
1	AFC	Adafruit Feather Compatible
2	AMC	Arduino MKR Compatible

Trademark notice

All referenced brands, product names, service names, and trademarks are the property of their respective owners.

Ordering info

NoNo	Item	SKU
1	qBoxMini AFC DIY IOT Enclosure Kit (No SMA)	IBT-QBM-AFC-0
2	qBoxMini AFC DIY IOT Enclosure Kit (One SMA)	IBT-QBM-AFC-1
3	qBoxMini AFC DIY IOT Enclosure Kit (Two SMAs)	IBT-QBM-AFC-2