

CM4 SENSIGN

AN EMBEDDED COMPUTER DESIGNED FOR IOT AND INDUSTRIAL
FIELD DATA ACQUISITION APPLICATION

Shanghai EDA Technology Co.,Ltd
2023-03-10

Copyright Statement

CM4 Sensing and its related intellectual property rights are owned by Shanghai EDA Technology Co., Ltd. Shanghai EDA Technology Co., Ltd owns the copyright of this document and reserves all rights. Without the written permission of Shanghai EDA Technology Co., Ltd, no part of this document may be modified, distributed or copied in any way or form.

Disclaimers

Shanghai EDA Technology Co., Ltd does not guarantee that the information in this manual is up to date, correct, complete or of high quality. Shanghai EDA Technology Co., Ltd also does not guarantee the further use of this information. If the material or non-material related losses are caused by using or not using the information in this manual, or by using incorrect or incomplete information, as long as it is not proved that it is the intention or negligence of Shanghai EDA Technology Co., Ltd, the liability claim for Shanghai EDA Technology Co., Ltd can be exempted. Shanghai EDA Technology Co., Ltd expressly reserves the right to modify or supplement the contents or part of this manual without special notice.

Contents

1	Product Overview	5
1.1	Target Application	5
1.2	Specifications and Parameters	5
1.3	System Diagram	6
1.4	Functional layout	7
1.5	Packing List	8
1.6	Order Code	8
1.7	Certificate	9
2	Product Appearance and Structure	10
2.1	Product Appearance	10
2.2	Product Photo	11
2.3	Dimensions	12
2.4	Mount Dimensional Drawings	13
2.4.1	DIN Mount	13
2.4.2	Wall Mount	14
3	Interfaces and Connectors	15
3.1	Front Panel	15
3.1.1	Power Input	15
3.1.2	Indicator Light	15
3.1.3	RS232	16
3.1.4	CAN Bus	16
3.1.5	RS485	17
3.2	Rear Panel	18
3.2.1	SIM Slot	19
3.2.2	SD Slot	19
3.2.3	HDMI	20
3.2.4	USB 2.0	20
3.2.5	Gigabit Ethernet	20
3.3	Antennas	20
4	Internal Interface	22
4.1	Micro-USB	22
4.2	Mini PCIe	22
4.3	RTC	23
4.4	Buzzer	23
4.5	HDMI DSI	23
4.6	HDMI FPC	24
5	Wireless Communication	26
5.1	WiFi	26
5.2	Bluetooth	26
5.3	4G LTE	26
5.4	Antennas	27
5.4.1	4G LTE Antenna	27
5.4.2	WiFi / BT Antenna	28

6	Electrical Characteristics	29
6.1	Electrical Parameters	29
6.1.1	V1.2	29
6.1.2	V1.1	29
7	Product Release Note	30
7.1	V1.2	30
7.2	V1.1	30
8	About Us	31
8.1	About EDATEC	31
8.2	Contact Us	31

1 Product Overview

CM4 Sensing is an embedded computer based on Raspberry Pi Compute Module 4 (CM4 for short), which is designed for IOT and industrial field data acquisition applications. It makes full use of CM4's structural flexibility to solve the heat dissipation problem of CPU, wireless module and PMU, and improves the reliability of wireless communication through external WIFI/BT antenna.

1.1 Target Application

- Industrial control
- IOT gateway
- Intelligent city
- Intelligence industry
- Smart manufacturing

1.2 Specifications and Parameters

Function	Parameters
CPU	BCM2711 4 core, ARM Cortex-A72(ARM v8), 1.5GHz, 64bit CPU
Memory	1GB / 2GB / 4GB / 8GB option
eMMC	8GB / 16GB / 32GB option
SD card	eMMC is used for the main file system, and it can also support TF card expansion for data storage.
Ethernet	1x Gigabit Ethernet
WiFi / Bluetooth	2.4G/5.8G dual-band WiFi, Bluetooth 5.0
4G communication	Support Quectel EC20 4G LTE module
HDMI	1x standard HDMI
HDMI FPC touch screen	1x FPC HDMI, support USB touch , PWM Dimming
DSI	1x DSI, Support Raspberry Pi 7-inch official touch screen
USB Host	2x USB 2.0 Type A, 1x USB 2.0 Integrated in Mini PCIe interface, 1x USB micro-B is used for eMMC burning.
RS485	4x RS485
RS232	1x RS232, Can be used in the default console of the system, and supports configuration as a standard serial port.
CAN BUS	1x CAN
Mini PCIe	1-lane PCIe 2.0, Highest support 5Gbps, 1x USB 2.0 Host

Function	Parameters
Real time clock	1x RTC
Buzzer	1x buzzer
DC power supply output	5V@1A, Can be used to support Raspberry Pi 7 inch official touch screen power supply.
LED Indicator	Red (power indicator), green (system status indicator)
Power input	V1.2 version is 8V~28V, V1.1 version is 8V~18V
Dimensions	102(L) x 73(W) x 35(H) mm
Case	Full Metal Jacket, support DIN slide rail installation.
Cooling fin	Full-face CNC aluminum alloy heat sink
Antenna accessory	Support optional WiFi/BT external antenna, which has passed wireless authentication together with Raspberry Pi CM4, and optional 4G external antenna.
Working environment temperature	Running at full speed at ambient temperature of-25 ~ 60 C.
OS	Compatible with official Raspberry Pi OS, provides BSP software support package, and supports online installation and update of APT.

1.3 System Diagram

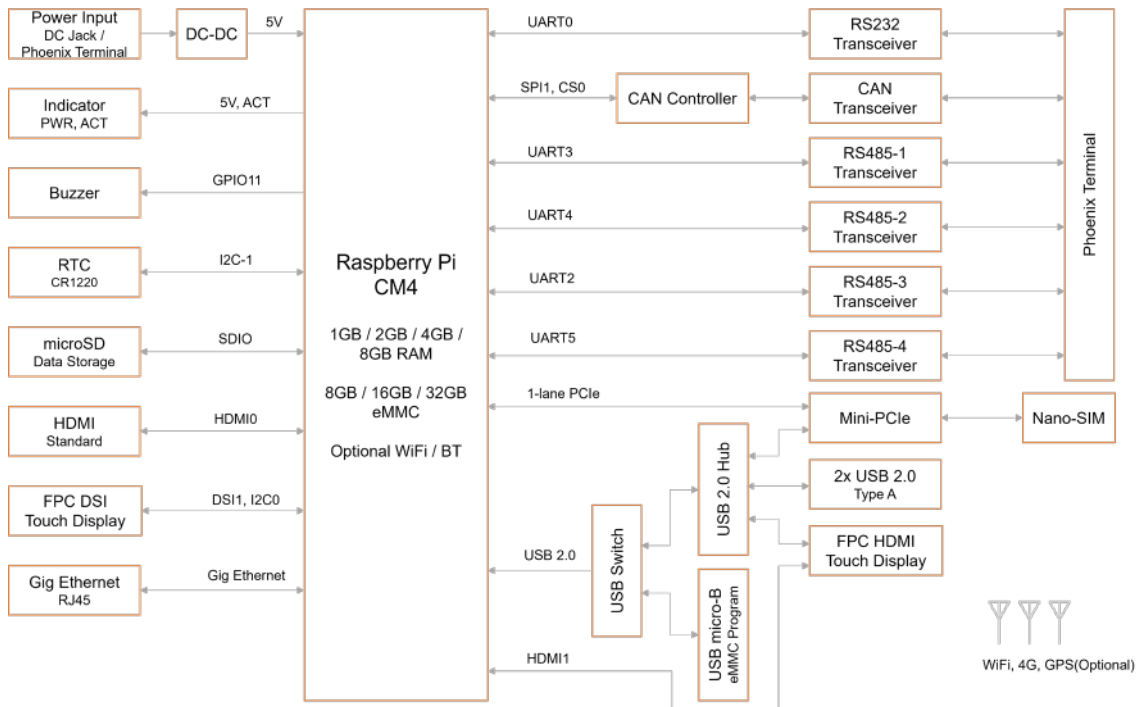

ED-CM4SEN12: EDATEC CM4 Sensing V1.2

NOTE : The power input range of V1.2 version is 8V ~ 28V, and that of V1.1 version is 8V ~ 18V.

1.4 Functional layout

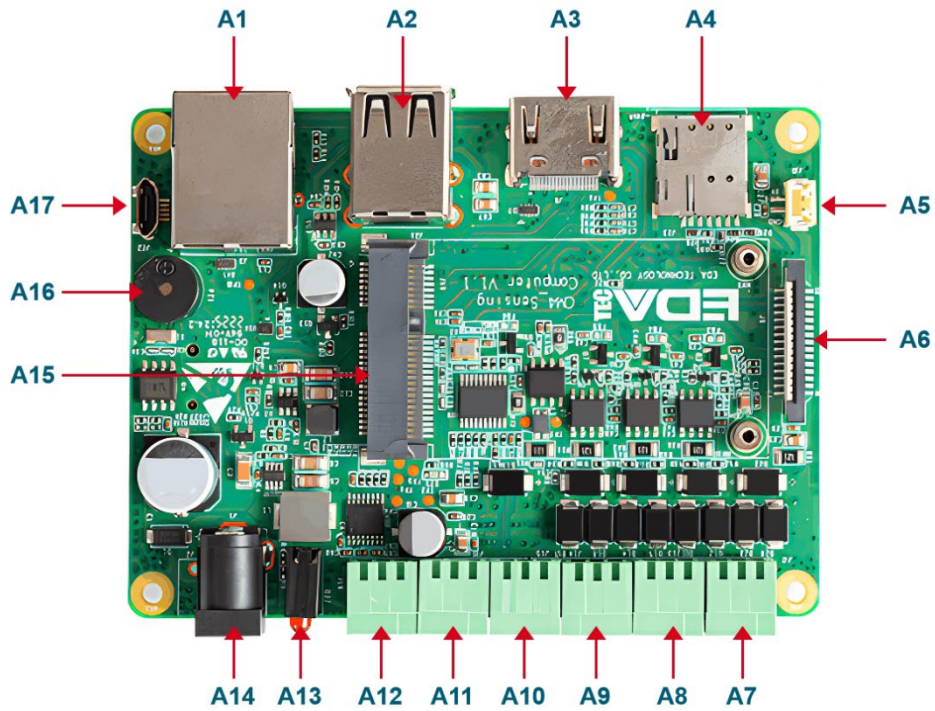

Item	Function Description	Item	Function Description
A1	Gigabit Ethernet	A2	USB 2.0
A3	Standard HDMI port	A4	SIM slot
A5	5V 1A output	A6	HDMI DSI
A7	RS485-4	A8	RS485-3
A9	RS485-2	A10	RS485-1
A11	CAN	A12	RS
A13	Indicator	A14	DC power input
A15	Mini PCIe	A16	buzzer
A17	Micro USB flash port		

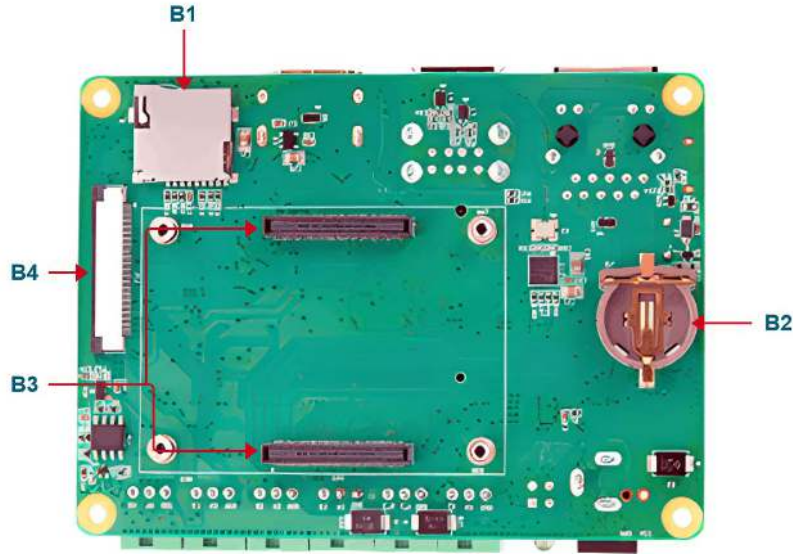

Item	Function Description	Item	Function Description
B1	Micro SD card slot	B2	RC1220 Button cell, RTC power supply
B3	CM4	B4	HDMI FPC

1.5 Packing List

- 1x CM4 Sensing host
- [option WiFi/BT version] 1x 2.4GHz/5GHz WiFi/BT antenna
- [option 4G version] 1x 4G/LTE antenna

1.6 Order Code

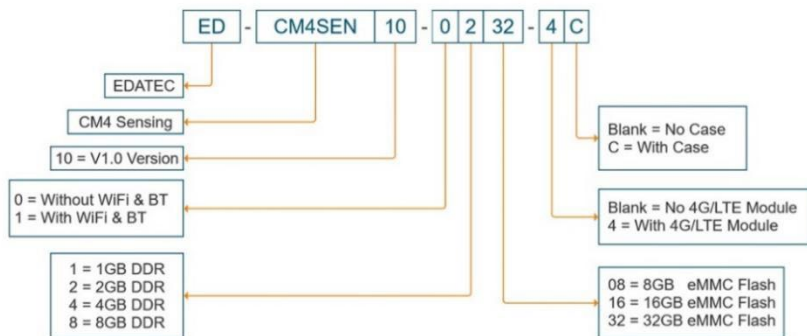

Example

Part#: ED-CM4SEN10-1408-4C

Configuration: CM4 Sensing Computer V1.0 version
 1PCS Raspberry Pi certified WiFi/Bluetooth Antenna
 4GB DDR, 8GB eMMC Flash, with 4G/LTE Module
 With case

1.7 Certificate

Support FCC, CE, KC and WPC.

2 Product Appearance and Structure

2.1 Product Appearance

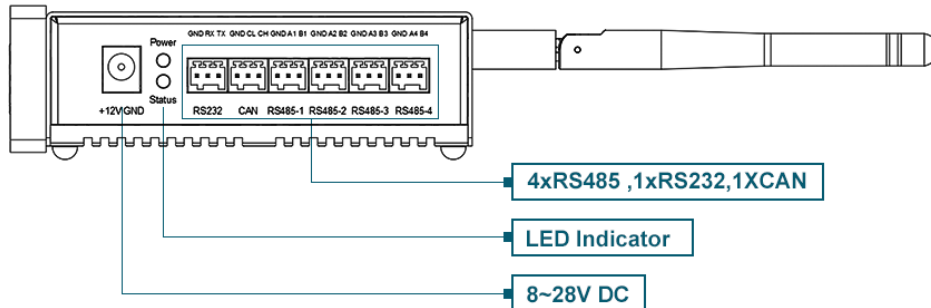

NOTE : The power input range of V1.2 version is 8V ~ 28V, and that of V1.1 version is 8V ~ 18V.

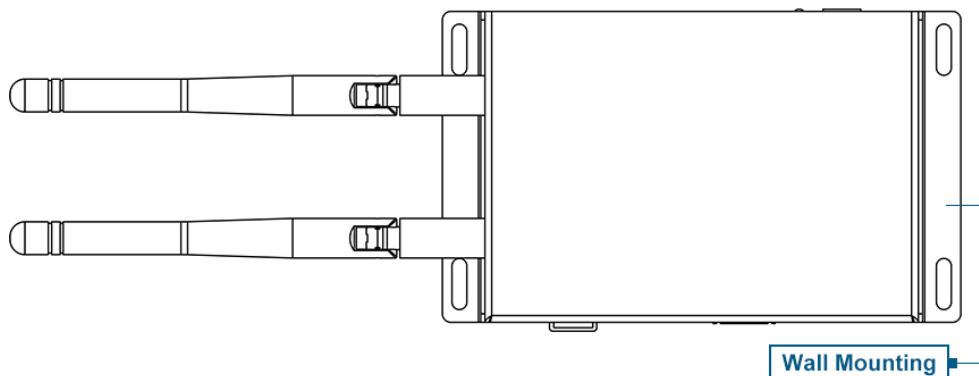
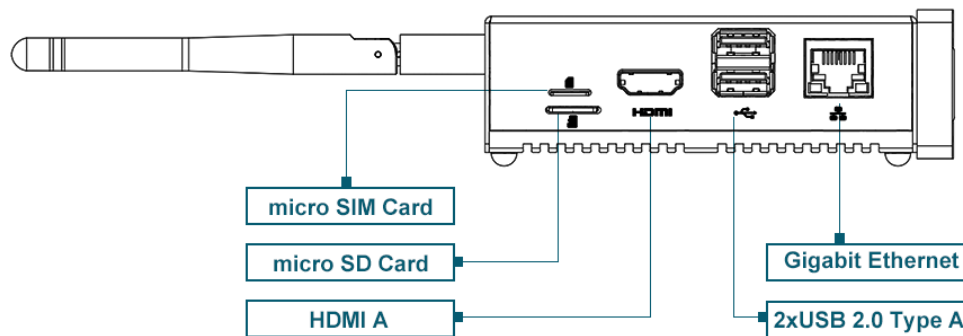

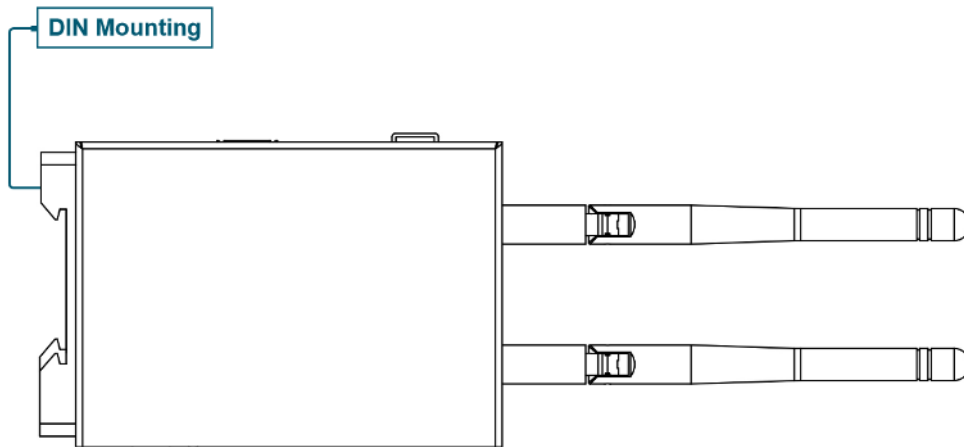

2.2 Product Photo

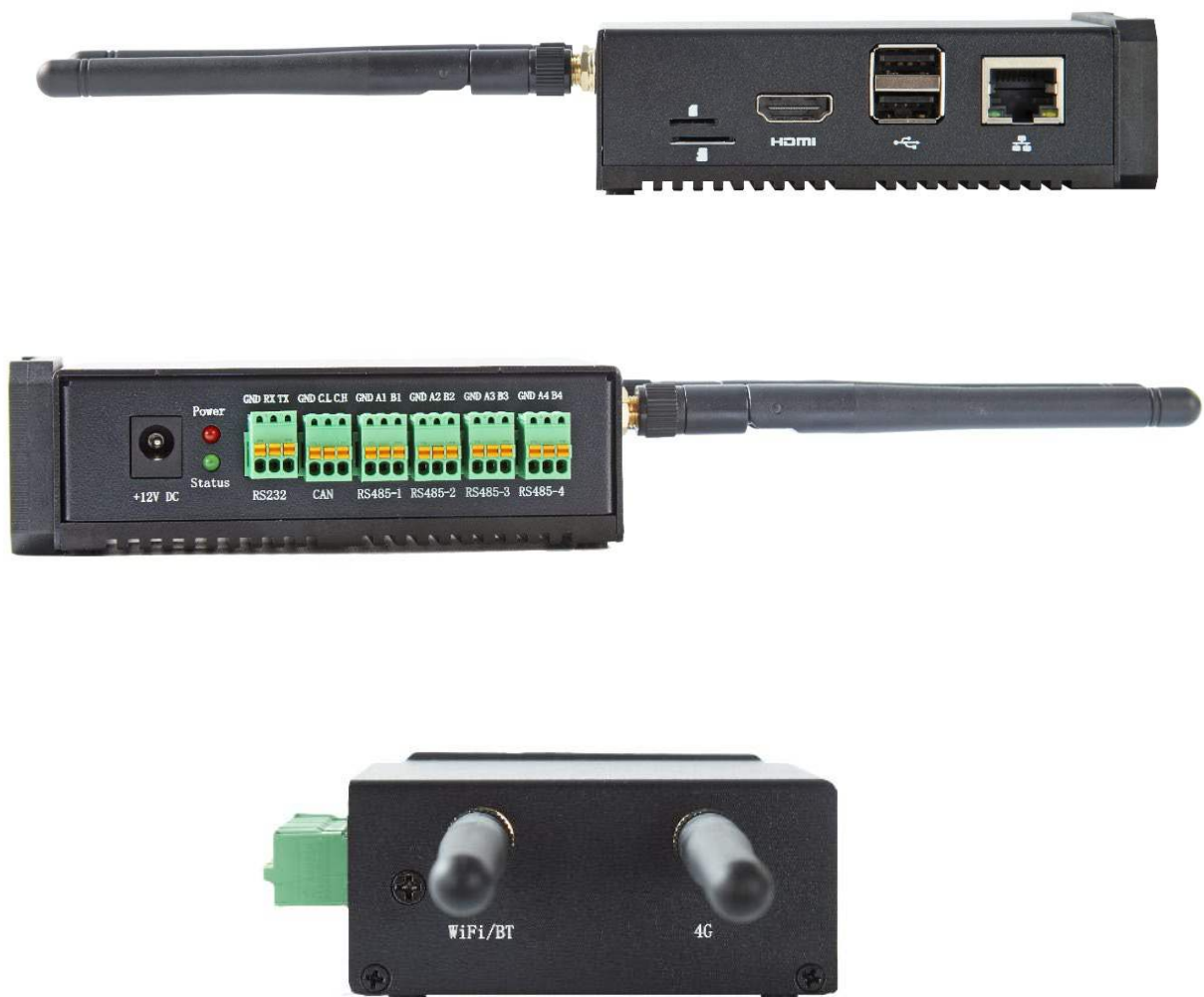

2.3 Dimensions

unit: mm, tolerance: $\pm 0.1\text{mm}$

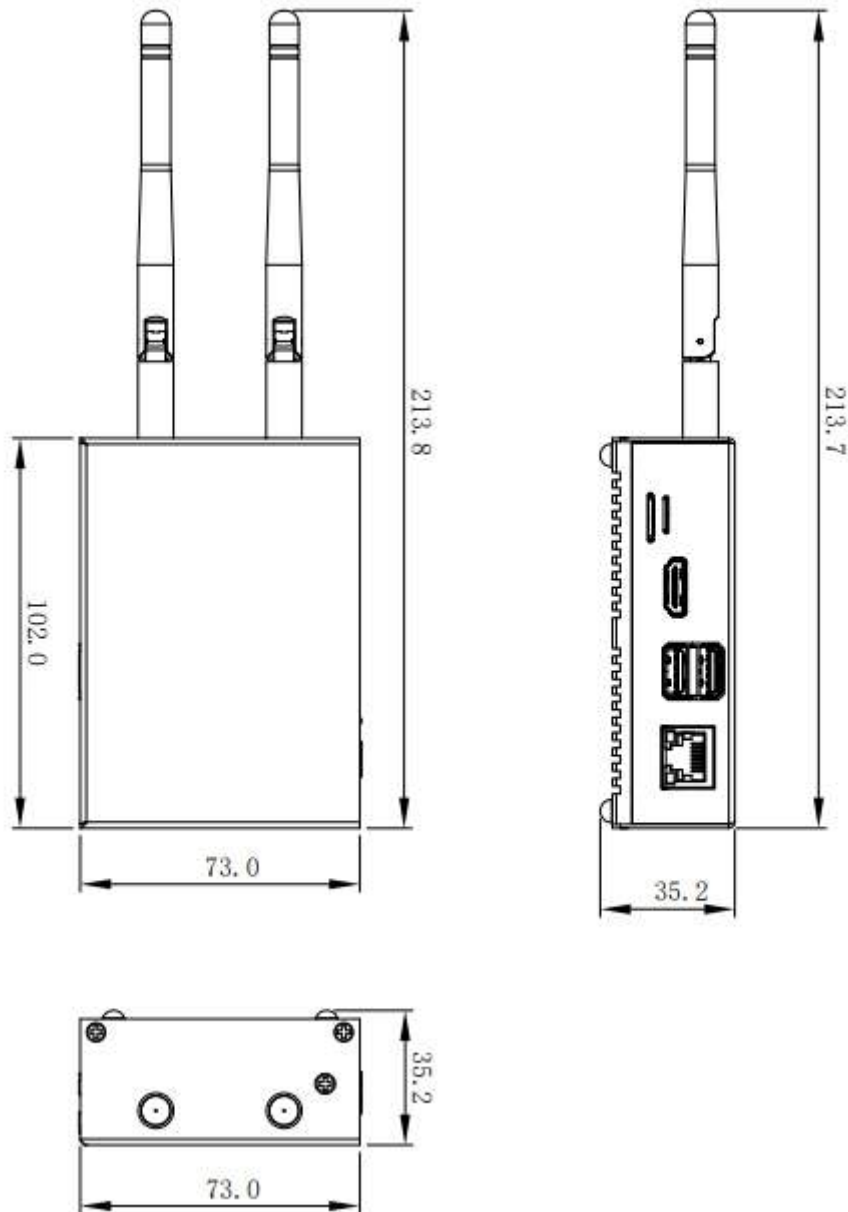

2.4 Mount Dimensional Drawings

2.4.1 DIN Mount

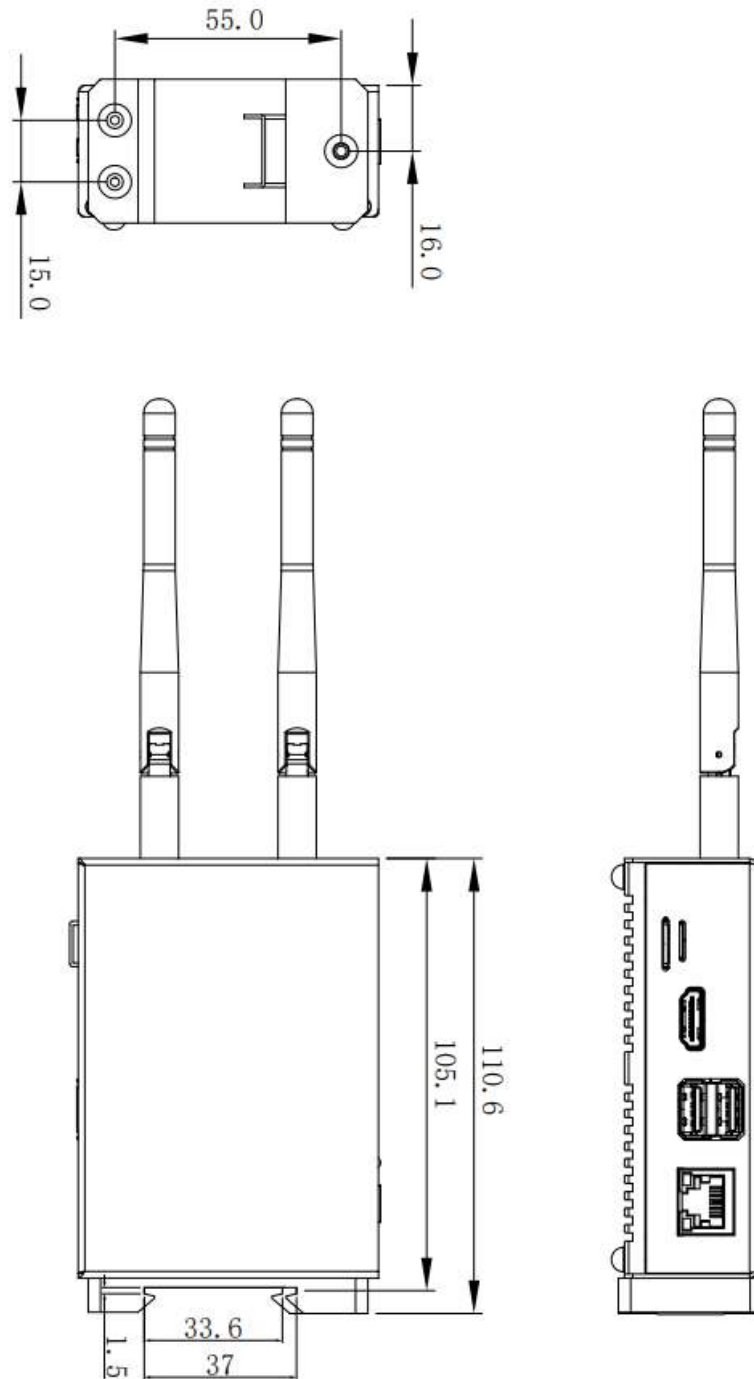

2.4.2 Wall Mount

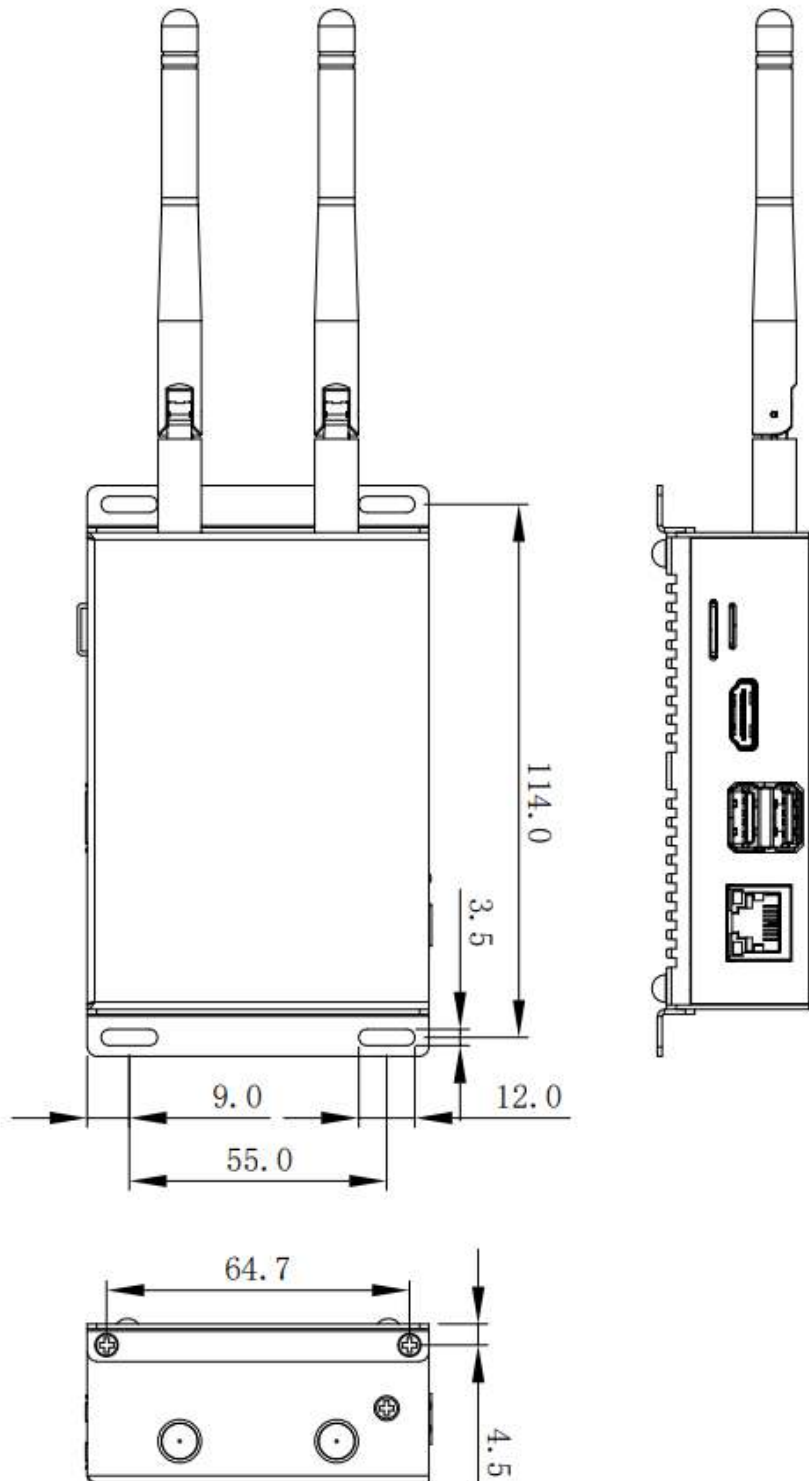

3 Interfaces and Connectors

3.1 Front Panel

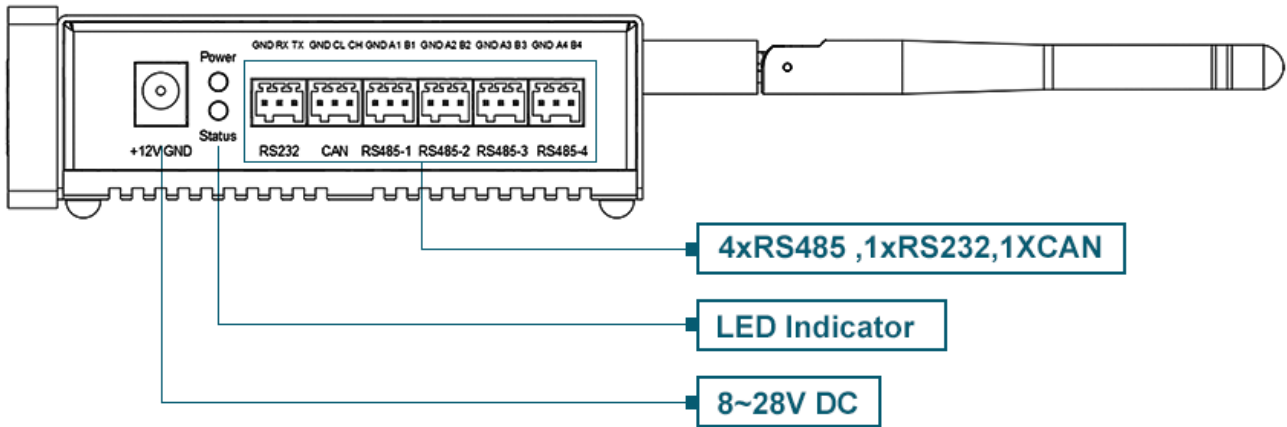

3.1.1 Power Input

The power interface is on the right panel, using DC Jack interface. The power input range of V1.2 version is 8 ~ 28V, and the power input range of V1.1 version is 8 ~ 18V, with positive inside and negative outside. Recommend customers to use a 12V power adapter.



3.1.2 Indicator Light

CM4 Sensing has 2 indicator lights:

Indicator	Description
Red LED	Power light
Green LED	Used to indicate the reading and writing of eMMC, and can also be used to judge the cause of startup failure.

tip: Green LED can also be used to analyze and judge the cause of system startup failure. Please refer to the software manual for details.

3.1.3 RS232

There is one RS232 on CM4 Sensing, which corresponds to UART0 on BCM2711. Using SP3232 level conversion chip, it directly outputs 232 level at Phoenix terminal.

	Pin	Definition
	1	GND
	2	RX
3	TX	

The RS232 interface device name of CM4 Sensing is as follows:

Interface name	Device name
RS232	/dev/serial0

3.1.4 CAN Bus

There is a CAN bus on CM4 Sensing, which is extended and integrated with CAN transceiver through SPI. The definition of Pin is shown in the following table.

	Pin	Definition
	1	GND
	2	CL
3	CH	

The device name of the can bus interface of CM4 Sensing are as follows:

Interface name	Device name
CAN	/sys/class/net/can0

3.1.5 RS485

There are four RS485 channels on CM4 Sensing, all of which correspond to the native serial port on BCM2711, and the level conversion is done by using SP3485 interface chip, which supports automatic switching of transmission and reception. The following table lists the Pin definitions of each 485 interface.

WARN: CM4 Sensing RS485 circuit is configured with 120 ohm terminal resistance (between A and B) by default.

3.1.5.1 RS485-1

	Pin	Definition
	1	GND
	2	A
	3	B

The device name of the RS485-1 interface of CM4 Sensing are as follows:

Interface name	Device name
RS485-1	/dev/ttyAMA2

3.1.5.2 RS485-2

	Pin	Definition
	1	GND
	2	A
	3	B

The device name of the RS485-2 interface of CM4 Sensing are as follows:

Interface name	Device name
RS485-2	/dev/ttyAMA3

3.1.5.3 RS485-3

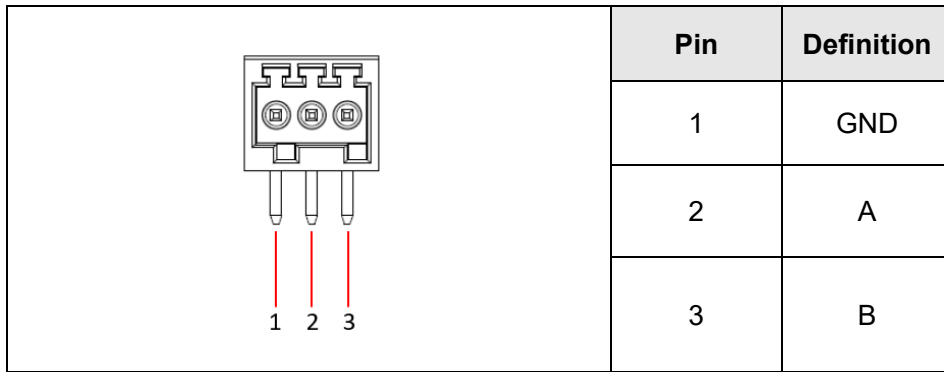

The device name of the RS485-3 interface of CM4 Sensing are as follows:

Interface name	Device name
RS485-3	/dev/ttyAMA1

3.1.5.4 RS485-4

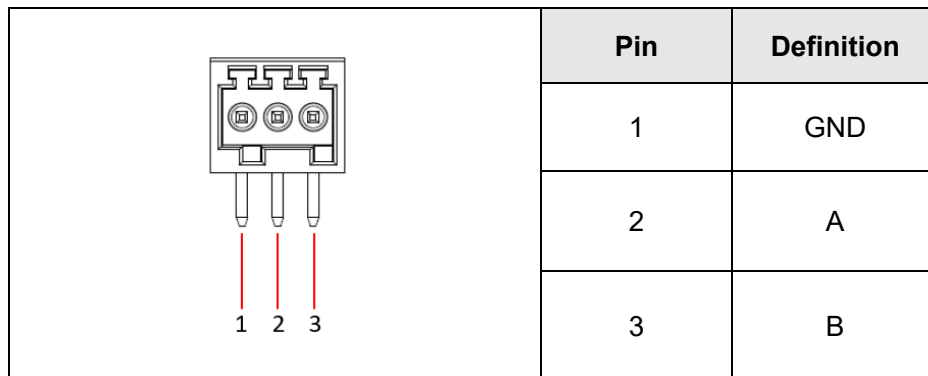

The device name of the RS485-4 interface of CM4 Sensing are as follows:

Interface name	Device name
RS485-4	/dev/ttyAMA4

3.2 Rear Panel

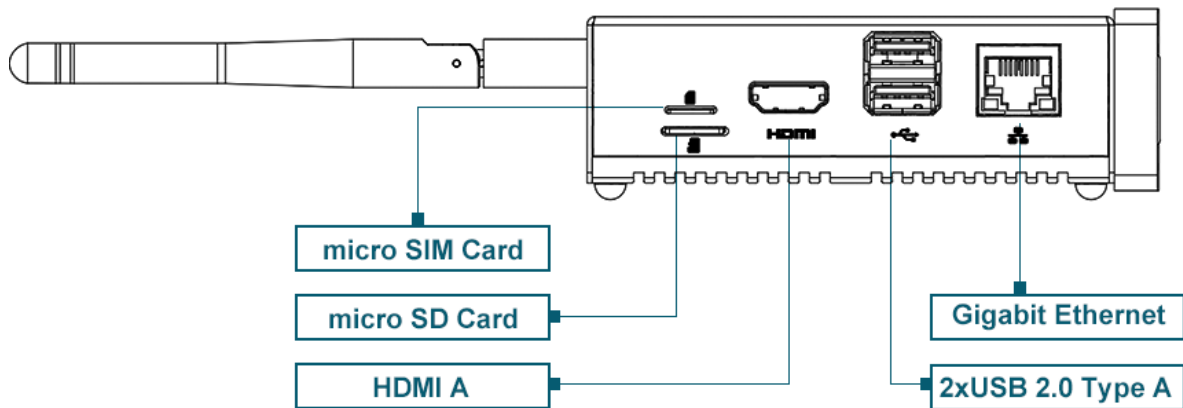

3.2.1 SIM Slot

Users can choose whether it contains 4G module. We have configured the EC20 full netcom 4G module in China, which supports mobile, China Unicom and telecom network standards, with optional GPS support.

The 4G module is extended by USB 2.0, and supports one Nano-SIM card.



3.2.2 SD Slot

CM4 Sensing supports dual storage scheme, eMMC+micro SD card. eMMC is used for the main file system, and micro SD card can be used for expanding data storage. Users can choose SD cards with different capacities to store data according to application requirements. Compared with the built-in eMMC memory, SD cards have larger capacity and lower cost. Users can use eMMC on CM4 to store system code and SD card to store application data.

tip: Micro SD card can only be used for extended storage and cannot be boot from SD card.

3.2.3 HDMI

CM4 Sensing has a standard HDMI Type A (full size) interface, which uses CM4 HDMI0 signals and supports HDMI2.1 video output with a maximum resolution of 4Kp60.

3.2.4 USB 2.0

CM4 Sensing has 2 USB 2.0 Type-A, which uses a double-layer USB Type-A connector. In addition, there is a USB 2.0 on mini-PCIe, which can be used to expand 4G and other functional modules, and there is a USB 2.0 on FPC HDMI connector to support USB touch screen.

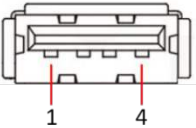
	Pin ID	Pin Name
	1	5V
	2	D-
	3	D+
	4	GND

3.2.5 Gigabit Ethernet

There is an adaptive 10/100/1000Mbps Ethernet on CM4 Sensing, which uses RJ45 interface. It is recommended to use Cat6 (Category 6) network cable.

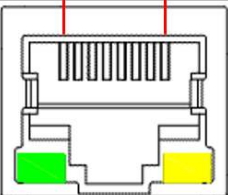
	Pin ID	Pin Name
	1	TRD0+
	2	TRD0-
	3	TRD1+
	4	TRD2+
	5	TRD2-
	6	TRD1-
	7	TRD3+
	8	TRD3-

3.3 Antennas

There are two standard SMA head antenna interfaces on the side of CM4 Sensing shell, which correspond to 4G antenna and WiFi/BT antenna respectively.

4 Internal Interface

4.1 Micro-USB



J22 USB micro-B interface for eMMC burning.

tip: From the security point of view, to prevent malicious burning, it is necessary to disassemble the case to access the USB micro-B interface.

4.2 Mini PCIe

There is a Mini PCIe expansion interface on CM4 Sensing, which can expand some peripherals, such as 4G and NPU.

Pin	Definition	Pin	Definition
1	GND	28	NC
2	3V3	29	GND
3	B1	30	NC
4	GND	31	PCIE_TXN
5	NC	32	NC
6	NC	33	PCIE_TXP
7	PCIE_CLK_nREQ	34	GND
8	USIM_VDD	35	GND
9	GND	36	USB_DM
10	USIM_DATA	37	GND
11	GND	38	USB_DP
12	USIM_CLK	39	3V3
13	PCIE_CLKP	40	GND
14	USIM_RST	41	3V3
15	GND	42	LED_WWAN

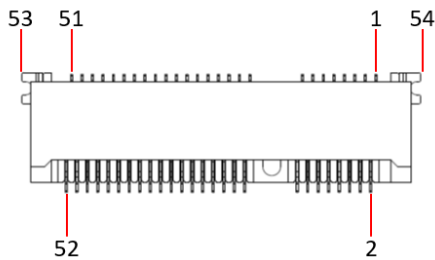

	16	NC	43	GND
	17	NC	44	NC
	18	GND	45	NC
	19	NC	46	NC
	20	NC	47	NC
	21	GND	48	NC
	22	GPIO10/PCIE_nRST	49	NC
	23	PCIE_RXN	50	GND
	24	3V3	51	NC
	25	PCIE_RXP	52	3V3
	26	GND	53	GND
	27	GND	54	GND

4.3 RTC

CM4 Sensing is integrated with RTC. For the version sold in China, we will install CR1220 button cell (RTC backup power supply) by default when shipping. In this way, the system can be guaranteed to have an uninterrupted and reliable clock, which is not affected by factors such as equipment power down.

4.4 Buzzer

CM4 Sensing has a buzzer, which is controlled by GPIO11, enabled at high level and disabled at low level.

4.5 HDMI DSI

J8 is MIPI DSI interface, which uses DSI1 signals of 2-lane on CM4, and can be used with Raspberry Pi official 7-inch touch screen.

	Pin	Definition	Pin	Definition

	1	GND	9	DSI1_D0_P
	2	DSI1_D1_N	10	GND
	3	DSI1_D1_P	11	SCL0
	4	GND	12	SDA0
	5	DSI1_CLK_N	13	GND
	6	DSI1_CLK_P	14	3V3
	7	GND	15	3V3
	8	DSI1_D0_N		

4.6 HDMI FPC

On the back of the development board, J12 uses CM4 HDMI1 signal, in the form of FPC, with USB 2.0 touch screen signal and PWM brightness level signal reserved on it, which can be connected to HDMI touch screen.

	Pin	Definition	Pin	Definition
	1	NC	21	GND
	2	NC	22	HDMI1_CLKP
	3	NC	23	HDMI1_CLKN
	4	NC	24	GND
	5	GND	25	BACKLIGHT_PWM
	6	USB_DP	26	GND
	7	USB_DM	27	GND
	8	GND	28	GND
	9	HDMI1_HPD	29	GND
	10	HDMI1_SCL	30	GND
11	HDMI1_SDA	31	GND	

	12	GND	32	LCD_PWR_EN
	13	HDMI1_TX2P	33	GND
	14	HDMI1_TX2N	34	GND
	15	GND	35	GND
	16	HDMI1_TX1P	36	GND
	17	HDMI1_TX1N	37	GND
	18	GND	38	GND
	19	HDMI1_TX0P	39	GND
	20	HDMI1_TX0N	40	5V

5 Wireless Communication

5.1 WiFi

Customers can choose CM4 Sensing with WiFi version, which supports 2.4 GHz and 5.0 GHz IEEE 802.11b/G/N/AC dual-band WiFi.

2.4G band

Parameter	Feature
Frequency range	802.11b/g/n(HT20): 2412-2472MHz 802.11n(HT40): 2422-2462MHz
Modulation system	802.11b:DSSS 802.11g/n:OFDM
Frequency Step	5M

5G band

Parameter	Feature
Frequency range	802.11a/n/ac: 5150-5350MHz 5470-5725MHz 5725-5850MHz
Modulation system	BPSK
Frequency Step	5M

5.2 Bluetooth

CM4 Sensing supports Bluetooth 5.0.

Parameter	Feature
Frequency range	2402-2480MHz
Modulation system	GFSK,DPSK
Frequency Step	2M

5.3 4G LTE

Users can choose whether it contains 4G module. We have configured the Quectel EC20 full netcom 4G module in China, which supports mobile, China Unicom and telecom network standards, with optional GPS support.

#	4G Module	Support Country	Supported Frequency Band
---	-----------	-----------------	--------------------------

1	EC20-CE	China / India	LTE FDD: B1/B3 LTE TDD: B38/B39/B40/B41 TDSCDMA: B34/B39 WCDMA: B1 CDMA 1x/EVDO: BC0 GSM: 900/1800MH
2	EC25-AFX	North America	LTE-FDD: B2/B4/B5/B12/B13/B14/B66/B71 LTE-TDD: / WCDMA: B2/B4/B5 GSM/EDGE: /
3	EC25-AUX	Latin America / Australia / New Zealand	LTE-FDD: B1/B2/B3/B4/B5/B7/B8/B28 LTE-TDD: B40 WCDMA: B1/B2/B4/B5/B8 GSM/EDGE: B2/B3/B5/B8
4	EC25-EUX	EMEA / Thailand	LTE-FDD: B1/B3/B7/B8/B20/B28A LTE-TDD: B38/B40/B41 WCDMA: B1/B8 GSM/EDGE: B3/B8

The 4G module is extended by USB 2.0, and supports one Nano-SIM card.



tip: Using 4G will occupy the Mini PCIe interface.

5.4 Antennas

5.4.1 4G LTE Antenna

Parameter	Feature
Antenna type	External antenna
frequency band	LTE-FDD, LTE-TDD
frequency range	698-894MHz, 1710-2200MHz, 2496-2690MHz
antenna gain	2 dBi
impedance	50 OHM

5.4.2 WiFi / BT Antenna

Parameter	Feature
Antenna type	External antenna
frequency band	2400-2500MHz, 5150-5850 MHz
antenna gain	2 dBi
impedance	50 OHM

6 Electrical Characteristics

6.1 Electrical Parameters

6.1.1 V1.2

Parameters	Minimum	Typical	Max	Unit
System power input	8	12	28	V
Working temperature	-25	25	60	°C
Storage temperature	-25	25	60	°C
Working environment humidity	20		90	%

6.1.2 V1.1

Parameters	Minimum	Typical	Max	Unit
System power input	8	12	18	V
Working temperature	-25	25	60	°C
Storage temperature	-25	25	60	°C
Working environment humidity	20		90	%

7 Product Release Note

7.1 V1.2

- Expand the input voltage range from 8V~18V to 8V~28V.

7.2 V1.1

- Optimize some circuit designs and circuit board designs.

8 About Us

8.1 About EDATEC

EDATEC, located in Shanghai, is one of Raspberry Pi's global design partners. Our vision is to provide hardware solutions for Internet of Things, industrial control, automation, green energy and artificial intelligence based on Raspberry Pi technology platform.

We provide standard hardware solutions, customized design and manufacturing services to speed up the development and time to market of electronic products.

8.2 Contact Us

Mail - sales@edatec.cn / support@edatec.cn

Phone - +86-18621560183

Website - <https://www.edatec.cn>

Address - Room 301, Building 24, No.1661 Jialuo Highway, Jiading District, Shanghai