

## TSYS02D PERIPHERAL MODULE

### Digital Temperature Sensor

#### General Description

The TSYS02D peripheral module provides the necessary hardware to interface the TSYS02D digital temperature sensor to any system that utilizes Pmod compatible expansion ports configurable for I<sup>2</sup>C communication. The TSYS02D sensor is a self-contained temperature sensor that is fully calibrated during manufacture. The sensor can operate from 1.5V to 3.6V. The TSYS02D has a low power stand-by mode for power-sensitive applications.

#### Specifications

- Measures temperature from -40°C to 125°C
- I<sup>2</sup>C communication
- Fully calibrated
- Fast response time
- Very low power consumption

#### Features

- 12-pin Pmod compatible connector
- I<sup>2</sup>C interface
- Secondary 12-pin connector allows daisy chain
- FPGA fabric available for download
- $\mu$ C C code available for download
- 24/16 bit resolution for temperature
- Parameters stored on chip

## TSYS02D PERIPHERAL MODULE

Digital Temperature Sensor

### Performance

- -5°C to 50°C accuracy: 0.2°C
- -20°C to 100°C accuracy: 0.5°C
- -40°C to 125°C accuracy: 1°C
- Very low power consumption
- Operates from 1.5V to 3.6V
- Time constant – 4 second typical
- Conversion time – 43 mS typical

### Schematic

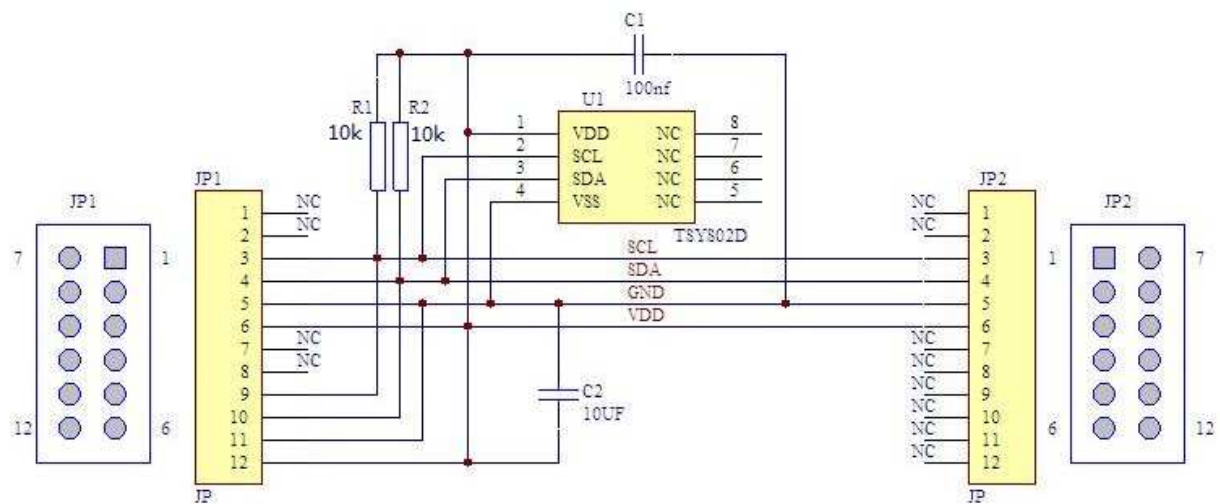

## TSYS02D PERIPHERAL MODULE

Digital Temperature Sensor

### Connector Pin Assignments (I<sup>2</sup>C Communications)

System Plug (Table 1)

Connector J1		
Pin No.	Signal	Description
1	N/C	Not Connected
2	N/C	Not Connected
3	SCL	I <sup>2</sup> C Serial Clock
4	SDA	I <sup>2</sup> C Serial Data
5	GND	Ground
6	Vdd	Power Supply
7	N/C	Not Connected
8	N/C	Not Connected
9	SCL	I <sup>2</sup> C Serial Clock
10	SDA	I <sup>2</sup> C Serial Data
11	GND	Ground
12	Vdd	Power Supply

Expansion Socket (Table 2)

Connector J2		
Pin No.	Signal	Description
1	N/C	Not Connected
2	N/C	Not Connected
3	SCL	I <sup>2</sup> C Serial Clock
4	SDA	I <sup>2</sup> C Serial Data
5	GND	Ground
6	Vdd	Power Supply
7	N/C	Not Connected
8	N/C	Not Connected
9	N/C	Not Connected
10	N/C	Not Connected
11	N/C	Not Connected
12	N/C	Not Connected

### Dimensions(mm)

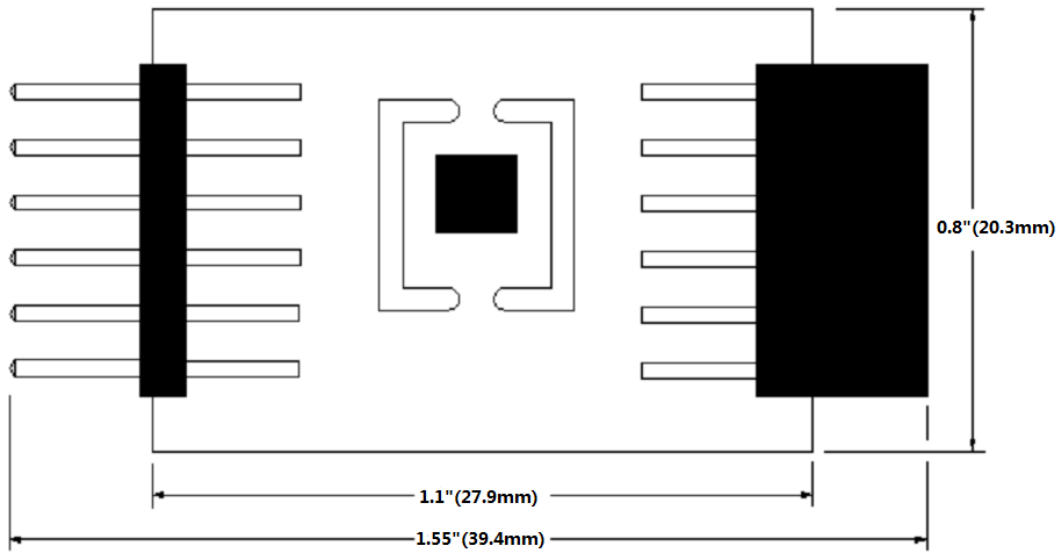

## TSYS02D PERIPHERAL MODULE

Digital Temperature Sensor

### Detailed Description

#### I<sup>2</sup>C Interface

The peripheral module can interface to the host in one of two ways. It can plug directly into a Pmod-compatible port (configured for I<sup>2</sup>C) through connector J1, or in this case, other I<sup>2</sup>C boards can attach to the same I<sup>2</sup>C bus through connector J2.

#### I<sup>2</sup>C Interface (Daisy Chaining Modules)

Alternatively, the peripheral module can connect to other I<sup>2</sup>C-based Pmod modules through the expansion J2 connector. Connector J1 provides connection of the module to the Pmod host. The pin assignments and functions adhere to the Pmod standard as shown in Table 1. The J2 connector allows the module to be connected through a daisy-chain from another I<sup>2</sup>C module and/or provide I<sup>2</sup>C and power connections to other I<sup>2</sup>C modules on the same bus. See Table 2.

#### External Control Signals

The IC operates as an I<sup>2</sup>C slave using the standard 2 wire I<sup>2</sup>C connection scheme. The IC is controlled either by the host (through the Pmod connector). In cases where one or more of the SCL and SDA signals are driven from an external source, resistors R1, R2 provide pull-up. However, this also increases the apparent load to the external driving source. If the external source is incapable of driving these loads, they should be removed.

### Reference Material

- Refer to the TSYS02D data sheet for detailed information regarding operation of the IC: <http://www.meas-spec.com/downloads/xxxxxxxx.pdf>
- The complete software sensor evaluation kit for ZEDBOARD is available at <http://www.meas-spec.com/TBD/xxxxx.zip> (TSYS02D ZedBoard Driver)
- The complete software sensor evaluation kit for MICROZED BOARD is available at <http://www.meas-spec.com/TBD/xxxxx.zip> (TSYS02D MicroZed Board Driver)
- The Boot.bin file of MicroZed Touch Screen Demo Kit for Digital Component Sensors at <http://www.meas-spec.com/TBD/xxxxx.zip> (MicroZed Touch Screen Demo)

### Ordering Information

Description	Part Number
TSYS02D PERIPHERAL MODULE	DPP202Z000

#### [te.com/en/products/sensors.html](http://te.com/en/products/sensors.html)

TE Connectivity, TE Connectivity (logo) and Every Connection Counts are trademarks. All other logos, products and/or company names referred to herein might be trademarks of their respective owners.

The information given herein, including drawings, illustrations and schematics which are intended for illustration purposes only, is believed to be reliable. However, TE Connectivity makes no warranties as to its accuracy or completeness and disclaims any liability in connection with its use. TE Connectivity's obligations shall only be as set forth in TE Connectivity's Standard Terms and Conditions of Sale for this product and in no case will TE Connectivity be liable for any incidental, indirect or consequential damages arising out of the sale, resale, use or misuse of the product. Users of TE Connectivity products should make their own evaluation to determine the suitability of each such product for the specific application.

© 2015 TE Connectivity Ltd. family of companies All Rights Reserved.

000000XX 03/15 Original

#### PRODUCT SHEET

##### Contact us:

Measurement Specialties Inc – MEAS France  
Impasse Jeanne Benozzi CS 83 163  
31027 Toulouse Cedex 3, FRANCE  
Tel: +33 (0)5 820.822.02 Fax: +33 (0)5.820.821.51  
Sales: [sales.lise.fr@meas-spec.com](mailto:sales.lise.fr@meas-spec.com)  
MEAS Website: [http://www.meas-spec.com/DCS\\_TBD](http://www.meas-spec.com/DCS_TBD)