



Am29030™ and Am29035™

RISC Microprocessors with 8-Kbyte/4-Kbyte Instruction Cache

Advanced
Micro
Devices

Am29030 MICROPROCESSOR DISTINCTIVE CHARACTERISTICS

- Full 32-bit architecture
- 26 million instructions per second (MIPS) sustained at 33 MHz
- 8-Kbyte, two-way set-associative instruction cache
- 33- and 25-MHz operating frequencies
- Scalable Clocking™ technology
- Programmable 16- or 32-bit data bus width
- CMOS technology/TTL-compatible
- 4-Gbyte virtual address space with demand paging
- Streamlined system interface for simplified, high-frequency operation
- Burst-mode and page-mode access support
- 8-, 16-, or 32-bit ROM interface
- 64-entry Memory Management Unit on-chip
- Fully pipelined
- On-chip timer facility
- 192 general-purpose registers
- Three-address instruction architecture
- Master/slave chip/output checking
- Software compatible with Am29005™ and Am29000® microprocessors
- Advanced debugging support
- IEEE Std 1149.1-1990 (JTAG) compliant Standard Test Access Port and Boundary Scan Architecture implementation

Am29035 MICROPROCESSOR DISTINCTIVE CHARACTERISTICS

The Am29035™ microprocessor is similar to the Am29030™ microprocessor except for the following differences:

- 4-Kbyte, direct-mapped instruction cache
- 16-MHz operating frequency
- 12 million instructions per second (MIPS) sustained at 16 MHz

SIMPLIFIED BLOCK DIAGRAM

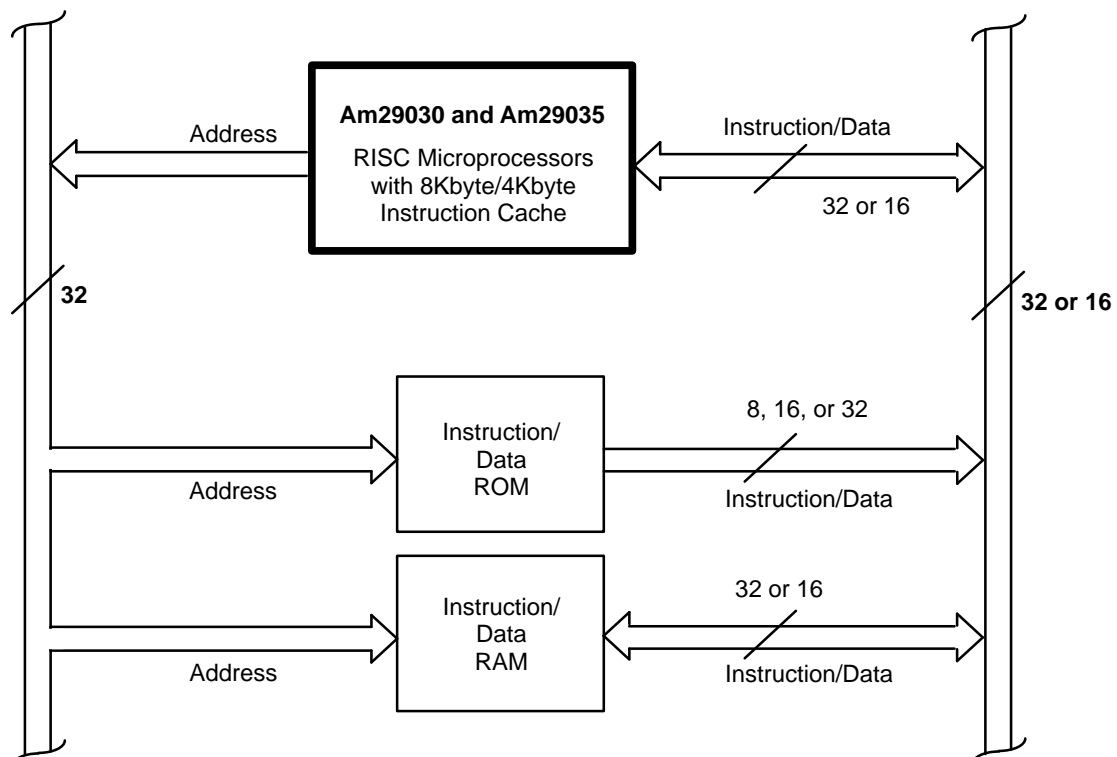

TABLE OF CONTENTS

DISTINCTIVE CHARACTERISTICS	1
Am29030 MICROPROCESSOR	1
Am29035 MICROPROCESSOR	1
SIMPLIFIED BLOCK DIAGRAM	1
GENERAL DESCRIPTION	3
29K FAMILY DEVELOPMENT SUPPORT PRODUCTS	3
RELATED AMD PRODUCTS	3
THIRD-PARTY DEVELOPMENT SUPPORT PRODUCTS	3
CONNECTION DIAGRAM	4
145-LEAD PGA PACKAGE	4
PGA Pin Designations by Pin Number	5
PGA Pin Designations by Pin Name	6
144-LEAD CERQUAD PACKAGE	7
Cerquad Pin Designations by Pin Number	8
Cerquad Pin Designations by Pin Name	9
LOGIC SYMBOL	10
ORDERING INFORMATION	11
ABSOLUTE MAXIMUM RATINGS	12
OPERATING RANGES	12
DC CHARACTERISTICS over COMMERCIAL operating ranges	12
CAPACITANCE	12
SWITCHING CHARACTERISTICS over COMMERCIAL operating range	13
PGA PACKAGE	13
CERQUAD PACKAGE	14
SWITCHING WAVEFORMS	15
CAPACITIVE OUTPUT DELAYS	16
SWITCHING TEST CIRCUIT	16
THERMAL CHARACTERISTICS	17
PHYSICAL DIMENSIONS	18
GQD 144—Cerquad Trimmed and Formed	18
CGY 145—Pin Grid Array—**Not currently available in this Acrobat file**	19

GENERAL DESCRIPTION

The Am29030 and Am29035 RISC microprocessors are high-performance, general-purpose, 32-bit microprocessors implemented in CMOS technology. Through high circuit densities and a high degree of on-chip integration, the Am29030 and Am29035 microprocessors are capable of operating at high internal frequencies while providing the designer with a simple streamlined external interface.

The Am29030 and Am29035 microprocessors were designed to meet the common requirements of embedded applications such as laser beam printers, graphics processors, X terminals and servers, Application Program Interface (API) accelerators, and scanners. The Am29030 and Am29035 microprocessors are well suited for these applications since they provide high

performance at low cost, and offer the designer complete design flexibility. Coupled with hardware and software development tools from AMD® and AMD's Fusion29K® partners, no design is ever far from the marketplace.

The Am29030 microprocessor is available in a 145-lead pin-grid-array (PGA) package and a 144-pin cerquad package. The PGA has 111 signal pins, 26 power and ground pins, 7 reserved pins, and 1 alignment/ground pin. The cerquad has 111 signal pins, 30 power and ground pins, and 3 reserved pins.

The Am29035 microprocessor is available in a 144-pin cerquad package.

29K™ Family Development Support Products

Contact your local AMD representative for information on the complete set of development support tools.

Software development products on several hosts:

- Optimizing compilers for common high-level languages
- Assembler and utility packages
- Source- and assembly-level software debuggers
- Target-resident development monitors
- Simulators
- EZ-030, an Am29030 microprocessor-based evaluation board kit

RELATED AMD PRODUCTS

29K Family Devices

Device	Description
Am29000®	Streamlined Instruction Microprocessor
Am29005™	Low-cost Streamlined Instruction Microprocessor
Am29050™	Streamlined Instruction Microprocessor with On-chip Floating Point
Am29200™	RISC Microcontroller
Am29205™	Low-cost RISC Microcontroller

Third-Party Development Support Products

The Fusion29K Program of Partnerships for Application Solutions provides the user with a vast array of products designed to meet critical time-to-market needs.

Products and solutions available through AMD's Fusion29K partners include:

- Silicon products
- Software generation and debug tools
- Hardware development tools
- Board level products
- Laser printer solutions
- Multiuser, kernel, and real-time operating systems
- Graphics solutions
- Networking and communications solutions
- Manufacturing support
- Custom support

CONNECTION DIAGRAM

145-Lead PGA
Bottom View

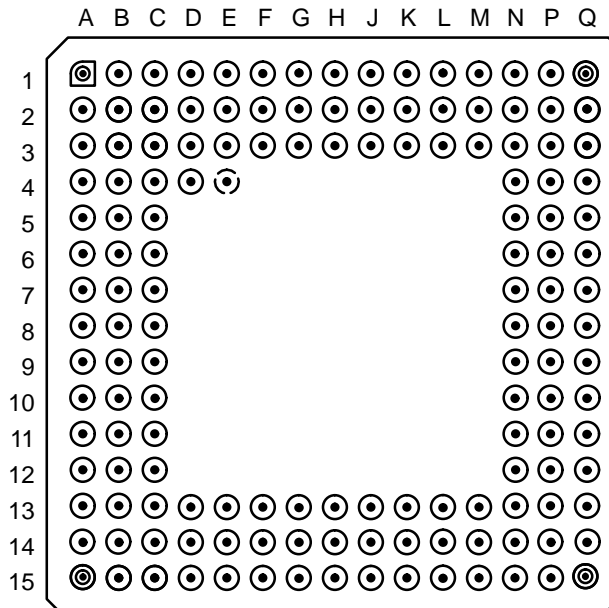

⊗ Pin Number E-4 is defined for emulator access and is not a physical pin on the package (see the Am29030 and Am29035 Microprocessors User's Manual, order #15723, Signal Description section).

Note: Pinout observed from pin side of package (pins facing viewer).

PGA PIN DESIGNATIONS

(Sorted by Pin Number)

Pin No.	Pin Name	Pin No.	Pin Name	Pin No.	Pin Name	Pin No.	Pin Name
A-1	ID4	C-8	GND	H-14	MEMCLK	N-12	Vcc
A-2	ID0	C-9	Vcc	H-15	$\overline{DIV2}$	N-13	A1
A-3	\overline{TRST}	C-10	GND	J-1	ID21	N-14	\overline{ERLYA}
A-4	TDI	C-11	Vcc	J-2	ID22	N-15	\overline{ERR}
A-5	TCK	C-12	STAT1	J-3	GND	P-1	ID31
A-6	\overline{TEST}	C-13	\overline{WBC}	J-13	INCLK	P-2	A30
A-7	I/\overline{D}	C-14	\overline{HIT}	J-14	PWRCLK	P-3	A27
A-8	IO/MEM	C-15	$\overline{INTR0}$	J-15	\overline{BREQ}	P-4	A24
A-9	$\overline{BWE0}$	D-1	ID12	K-1	ID23	P-5	A22
A-10	$\overline{BWE2}$	D-2	ID11	K-2	ID24	P-6	A20
A-11	SUP/ \overline{US}	D-3	ID9	K-3	Vcc	P-7	A18
A-12	OPT0	D-4	GND	K-13	GND	P-8	A15
A-13	OPT2	D-13	\overline{DI}	K-14	\overline{REQ}	P-9	A13
A-14	MPGM1	D-14	$\overline{INTR1}$	K-15	\overline{BURST}	P-10	A10
A-15	STAT2	D-15	$\overline{INTR2}$	L-1	ID25	P-11	A8
B-1	ID7	E-1	ID14	L-2	ID26	P-12	A6
B-2	ID6	E-2	ID13	L-3	Vcc	P-13	A4
B-3	ID3	E-3	GND	L-13	Vcc	P-14	A2
B-4	ID1	E-13	GND	L-14	\overline{BGRT}	P-15	A0
B-5	TDO	E-14	$\overline{INTR3}$	L-15	\overline{PGMODE}	Q-1	A31
B-6	TMS	E-15	$\overline{TRAP1}$	M-1	ID27	Q-2	A29
B-7	R/ \overline{W}	F-1	ID16	M-2	ID28	Q-3	A25
B-8	\overline{WARN}	F-2	ID15	M-3	NC	Q-4	A23
B-9	$\overline{BWE1}$	F-3	NC	M-13	GND	Q-5	A21
B-10	$\overline{BWE3}$	F-13	Vcc	M-14	\overline{RDN}	Q-6	A19
B-11	\overline{LOCK}	F-14	\overline{RESET}	M-15	\overline{RDY}	Q-7	A17
B-12	OPT1	F-15	$\overline{TRAP0}$	N-1	ID29	Q-8	A16
B-13	MPGM0	G-1	ID18	N-2	ID30	Q-9	A14
B-14	STAT0	G-2	ID17	N-3	NC	Q-10	A12
B-15	MSERR	G-3	Vcc	N-4	A28	Q-11	A11
C-1	ID10	G-13	Vcc	N-5	A26	Q-12	A9
C-2	ID8	G-14	CNTL0	N-6	GND	Q-13	A7
C-3	NC*	G-15	CNTL1	N-7	Vcc	Q-14	A5
C-4	ID5	H-1	ID20	N-8	GND	Q-15	A3
C-5	ID2	H-2	ID19	N-9	GND		
C-6	Vcc	H-3	GND	N-10	GND		
C-7	GND	H-13	GND	N-11	Vcc		

Notes:

- *1. NC = No connection internally.
2. Pin Number D-4 is the alignment/ground pin and must be electrically connected to ground.
3. Pin Number E-4 is defined for emulator access and is not a physical pin on the package (see Am29030 and Am29035 Microprocessors User's Manual, Signal Description section).

PGA PIN DESIGNATION

(Sorted by Pin Name)

Pin No.	Pin Name	Pin No.	Pin Name	Pin No.	Pin Name	Pin No.	Pin Name
P-15	A0	B-10	$\overline{\text{BWE3}}$	F-1	ID16	C-12	STAT1
N-13	A1	G-14	CNTL0	G-2	ID17	A-15	STAT2
P-14	A2	G-15	CNTL1	G-1	ID18	A-11	SUP/ $\overline{\text{US}}$
Q-15	A3	H-15	$\overline{\text{DIV2}}$	H-2	ID19	A-5	TCK
P-13	A4	N-14	$\overline{\text{ERLYA}}$	H-1	ID20	A-4	TDI
Q-14	A5	N-15	$\overline{\text{ERR}}$	J-1	ID21	B-5	TDO
P-12	A6	C-7	GND	J-2	ID22	A-6	$\overline{\text{TEST}}$
Q-13	A7	C-8	GND	K-1	ID23	B-6	TMS
P-11	A8	C-10	GND	K-2	ID24	F-15	$\overline{\text{TRAP0}}$
Q-12	A9	D-4	GND	L-1	ID25	E-15	$\overline{\text{TRAP1}}$
P-10	A10	E-3	GND	L-2	ID26	A-3	$\overline{\text{TRST}}$
Q-11	A11	E-13	GND	M-1	ID27	C-6	Vcc
Q-10	A12	H-3	GND	M-2	ID28	C-9	Vcc
P-9	A13	H-13	GND	N-1	ID29	C-11	Vcc
Q-9	A14	J-3	GND	N-2	ID30	F-13	Vcc
P-8	A15	K-13	GND	P-1	ID31	G-3	Vcc
Q-8	A16	M-13	GND	J-13	INCLK	G-13	Vcc
Q-7	A17	N-6	GND	C-15	$\overline{\text{INTR0}}$	K-3	Vcc
P-7	A18	N-8	GND	D-14	$\overline{\text{INTR1}}$	L-3	Vcc
Q-6	A19	N-9	GND	D-15	$\overline{\text{INTR2}}$	L-13	Vcc
P-6	A20	N-10	GND	E-14	$\overline{\text{INTR3}}$	N-7	Vcc
Q-5	A21	A-7	$\overline{\text{I/D}}$	A-8	IO/MEM	N-11	Vcc
P-5	A22	A-2	ID0	B-11	$\overline{\text{LOCK}}$	N-12	Vcc
Q-4	A23	B-4	ID1	H-14	MEMCLK	B-8	$\overline{\text{WARN}}$
P-4	A24	C-5	ID2	B-13	MPGM0		
Q-3	A25	B-3	ID3	A-14	MPGM1		
N-5	A26	A-1	ID4	B-15	MSERR		
P-3	A27	C-4	ID5	A-12	OPT0		
N-4	A28	B-2	ID6	B-12	OPT1		
Q-2	A29	B-1	ID7	A-13	OPT2		
P-2	A30	C-2	ID8	L-15	$\overline{\text{PGMODE}}$		
Q-1	A31	D-3	ID9	J-14	PWRCLK		
L-14	$\overline{\text{BGRT}}$	C-1	ID10	M-14	$\overline{\text{RDN}}$		
J-15	$\overline{\text{BREQ}}$	D-2	ID11	M-15	$\overline{\text{RDY}}$		
K-15	$\overline{\text{BURST}}$	D-1	ID12	F-14	$\overline{\text{RESET}}$		
A-9	$\overline{\text{BWE0}}$	E-2	ID13	K-14	$\overline{\text{REQ}}$	D-13	$\overline{\text{DI}}$
B-9	$\overline{\text{BWE1}}$	E-1	ID14	B-7	R/ $\overline{\text{W}}$	C-14	$\overline{\text{HIT}}$
A10	$\overline{\text{BWE2}}$	F-2	ID15	B-14	STAT0	C-13	$\overline{\text{WBC}}$
						RESERVED*	

Notes:

- *1. These following signals are reserved for future processor implementations. To maintain compatibility with future processor implementations, these pins should be connected to V_{CC} by individual pull-up resistors.
2. Pin Number D-4 is the alignment/ground pin and must be electrically connected to ground.
3. Pin Number E-4 is defined for emulator access and is not a physical pin on the package (see Am29030 and Am29035 Microprocessors User's Manual, Signal Description section).

CONNECTION DIAGRAM

144-Lead Cerquad Top View

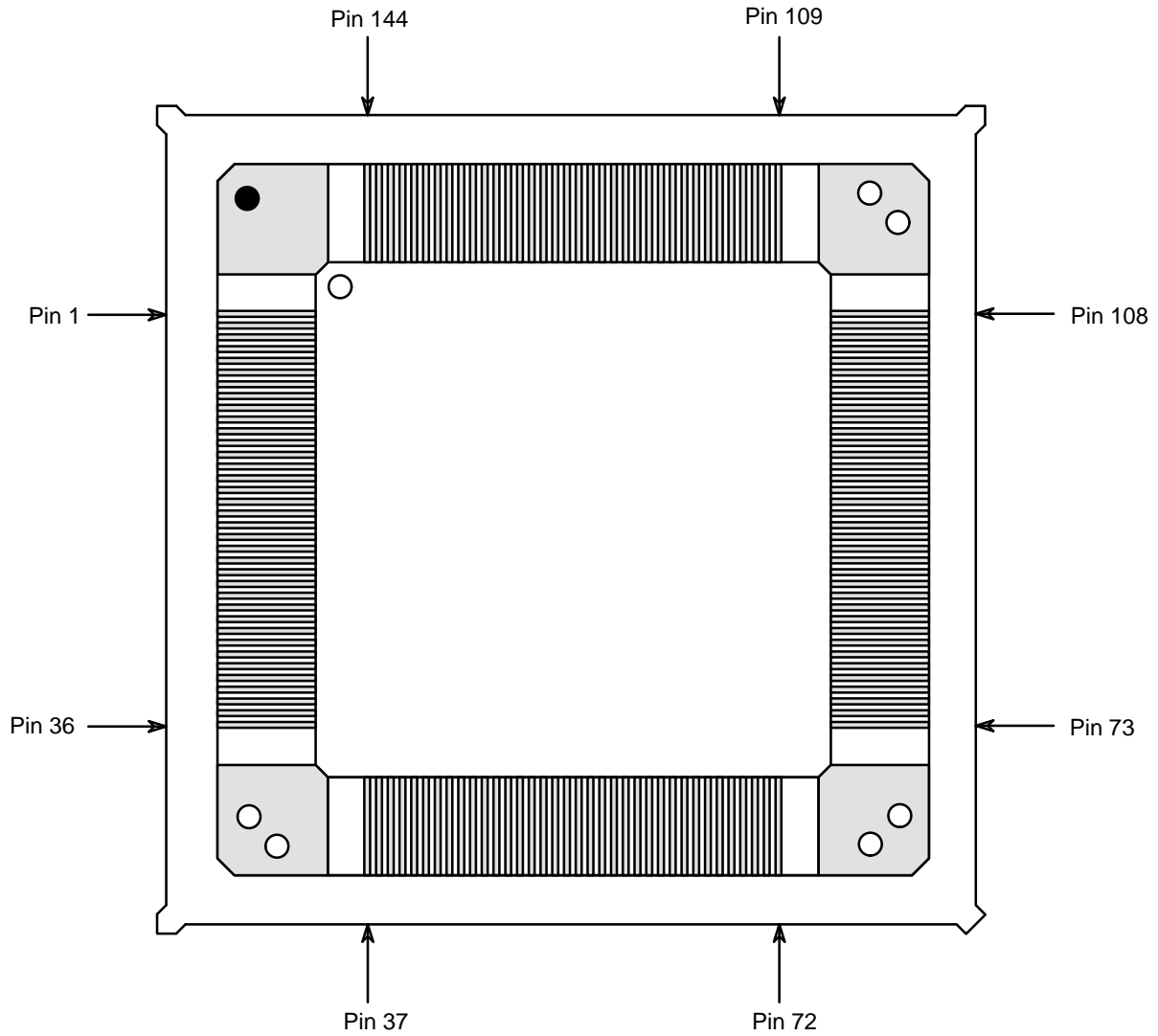

CERQUAD PIN DESIGNATIONS

(Sorted by Pin Number)

Pin No.	Pin Name	Pin No.	Pin Name	Pin No.	Pin Name	Pin No.	Pin Name
1	V _{CC}	37	V _{CC}	73	V _{CC}	109	A1
2	GND	38	GND	74	GND	110	A0
3	MSERR	39	ID5	75	A29	111	$\overline{\text{ERLYA}}$
4	STAT2	40	ID6	76	A28	112	$\overline{\text{ERR}}$
5	STAT1	41	ID7	77	A27	113	$\overline{\text{RDN}}$
6	STAT0	42	ID8	78	A26	114	$\overline{\text{RDY}}$
7	MPGM1	43	ID9	79	A25	115	$\overline{\text{BGRT}}$
8	MPGM0	44	ID10	80	A24	116	GND
9	OPT2	45	ID11	81	A23	117	V _{CC}
10	OPT1	46	ID12	82	A22	118	$\overline{\text{PGMODE}}$
11	OPT0	47	ID13	83	A21	119	$\overline{\text{BURST}}$
12	$\overline{\text{LOCK}}$	48	ID14	84	A20	120	$\overline{\text{REQ}}$
13	SUP/ $\overline{\text{US}}$	49	ID15	85	A19	121	$\overline{\text{BREQ}}$
14	$\overline{\text{BWE3}}$	50	V _{CC}	86	A18	122	GND
15	$\overline{\text{BWE2}}$	51	GND	87	A17	123	INCLK
16	$\overline{\text{BWE1}}$	52	ID16	88	A16	124	V _{CC}
17	$\overline{\text{BWE0}}$	53	ID17	89	V _{CC}	125	PWRCLK
18	V _{CC}	54	ID18	90	GND	126	MEMCLK
19	GND	55	ID19	91	V _{CC}	127	GND
20	$\overline{\text{WARN}}$	56	ID20	92	GND	128	V _{CC}
21	IO/ $\overline{\text{MEM}}$	57	ID21	93	A15	129	GND
22	I/ $\overline{\text{D}}$	58	ID22	94	A14	130	$\overline{\text{DIV2}}$
23	GND	59	ID23	95	A13	131	CNTL0
24	V _{CC}	60	GND	96	A12	132	CNTL1
25	R/ $\overline{\text{W}}$	61	V _{CC}	97	A11	133	V _{CC}
26	$\overline{\text{TEST}}$	62	GND	98	A10	134	GND
27	TCK	63	ID24	99	A9	135	$\overline{\text{RESET}}$
28	TMS	64	ID25	100	A8	136	$\overline{\text{TRAP0}}$
29	TDI	65	ID26	101	A7	137	$\overline{\text{TRAP1}}$
30	TDO	66	ID27	102	A6	138	$\overline{\text{INTR3}}$
31	$\overline{\text{TRST}}$	67	ID28	103	A5	139	$\overline{\text{INTR2}}$
32	ID0	68	ID29	104	A4	140	$\overline{\text{INTR1}}$
33	ID1	69	ID30	105	A3	141	$\overline{\text{INTR0}}$
34	ID2	70	ID31	106	A2	142	$\overline{\text{DI}}$
35	ID3	71	A31	107	GND	143	$\overline{\text{HIT}}$
36	ID4	72	A30	108	V _{CC}	144	$\overline{\text{WBC}}$

CERQUAD PIN DESIGNATIONS

(Sorted by Pin Name)

Pin No.	Pin Name	Pin No.	Pin Name	Pin No.	Pin Name	Pin No.	Pin Name
110	A0	16	$\overline{\text{BWE}}1$	45	ID11	125	PWRCLK
109	A1	15	$\overline{\text{BWE}}2$	46	ID12	113	$\overline{\text{RDN}}$
106	A2	14	$\overline{\text{BWE}}3$	47	ID13	114	$\overline{\text{RDY}}$
105	A3	131	CNTLO	48	ID14	135	$\overline{\text{RESET}}$
104	A4	132	CNTL1	49	ID15	120	$\overline{\text{REQ}}$
103	A5	130	$\overline{\text{DIV}}2$	52	ID16	25	$\text{R}/\overline{\text{W}}$
102	A6	111	$\overline{\text{ERLYA}}$	53	ID17	6	STAT0
101	A7	112	$\overline{\text{ERR}}$	54	ID18	5	STAT1
100	A8	2	GND	55	ID19	4	STAT2
99	A9	19	GND	56	ID20	13	$\text{SUP}/\overline{\text{US}}$
98	A10	23	GND	57	ID21	27	TCK
97	A11	38	GND	58	ID22	29	TDI
96	A12	51	GND	59	ID23	30	TDO
95	A13	60	GND	63	ID24	26	$\overline{\text{TEST}}$
94	A14	62	GND	64	ID25	28	TMS
93	A15	74	GND	65	ID26	136	$\overline{\text{TRAP}}0$
88	A16	90	GND	66	ID27	137	$\overline{\text{TRAP}}1$
87	A17	92	GND	67	ID28	31	$\overline{\text{TRST}}$
86	A18	107	GND	68	ID29	1	Vcc
85	A19	116	GND	69	ID30	18	Vcc
84	A20	122	GND	70	ID31	24	Vcc
83	A21	127	GND	123	INCLK	37	Vcc
82	A22	129	GND	141	$\overline{\text{INTR}}0$	50	Vcc
81	A23	134	GND	140	$\overline{\text{INTR}}1$	61	Vcc
80	A24	22	$\text{I}/\overline{\text{D}}$	139	$\overline{\text{INTR}}2$	73	Vcc
79	A25	32	ID0	138	$\overline{\text{INTR}}3$	89	Vcc
78	A26	33	ID1	21	$\text{IO}/\overline{\text{MEM}}$	91	Vcc
77	A27	34	ID2	12	$\overline{\text{LOCK}}$	108	Vcc
76	A28	35	ID3	126	MEMCLK	117	Vcc
75	A29	36	ID4	8	MPGM0	124	Vcc
72	A30	39	ID5	7	MPGM1	128	Vcc
71	A31	40	ID6	3	MSERR	133	Vcc
115	$\overline{\text{BGRT}}$	41	ID7	11	OPT0	20	$\overline{\text{WARN}}$
121	$\overline{\text{BREQ}}$	42	ID8	10	OPT1		
119	$\overline{\text{BURST}}$	43	ID9	9	OPT2		
17	$\overline{\text{BWE}}0$	44	ID10	118	PGMODE		

Note: The following signals are reserved for future processor implementations:

Pin No.	Pin Name
142	$\overline{\text{DI}}$
143	$\overline{\text{HIT}}$
144	$\overline{\text{WBC}}$

To maintain compatibility with future processor implementations, these pins should be connected to V_{CC} by individual pull-up resistors.

LOGIC SYMBOL

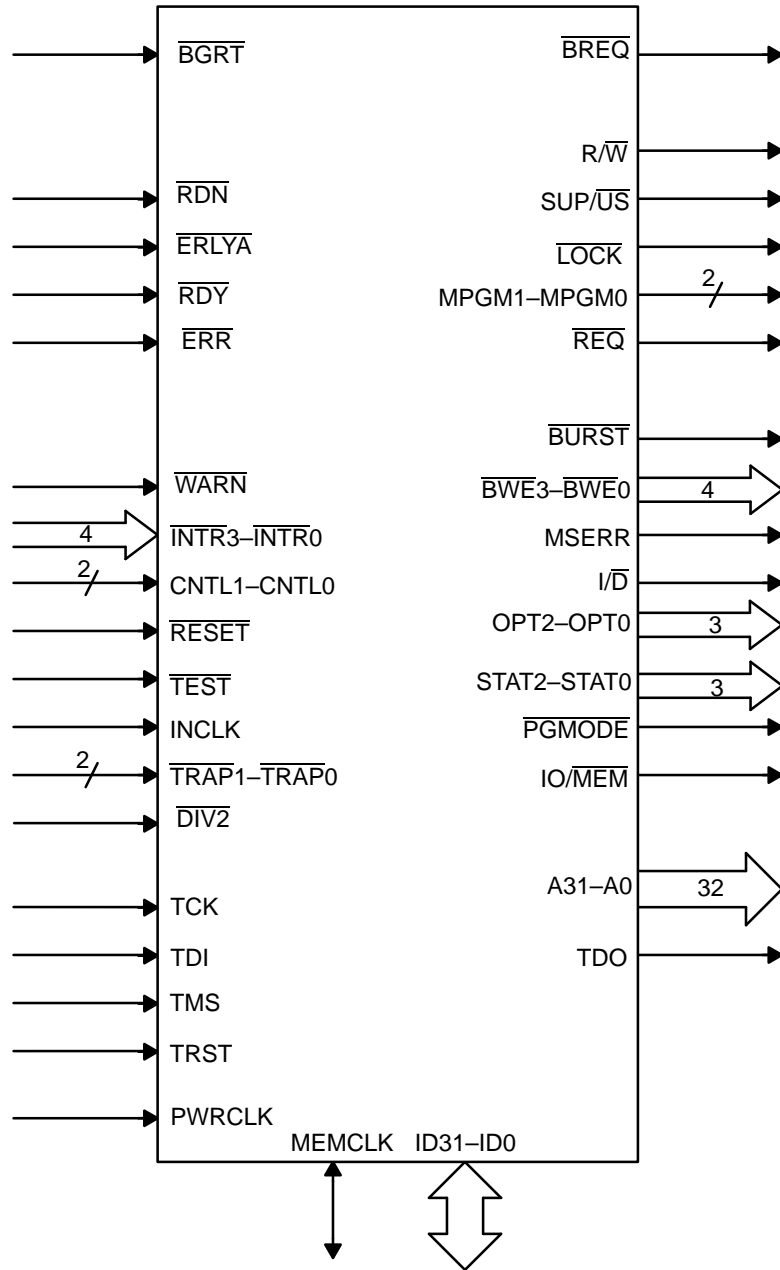

ORDERING INFORMATION

Standard Products

AMD standard products are available in several packages and operating ranges. The order number (Valid Combination) is formed by a combination of the elements below.

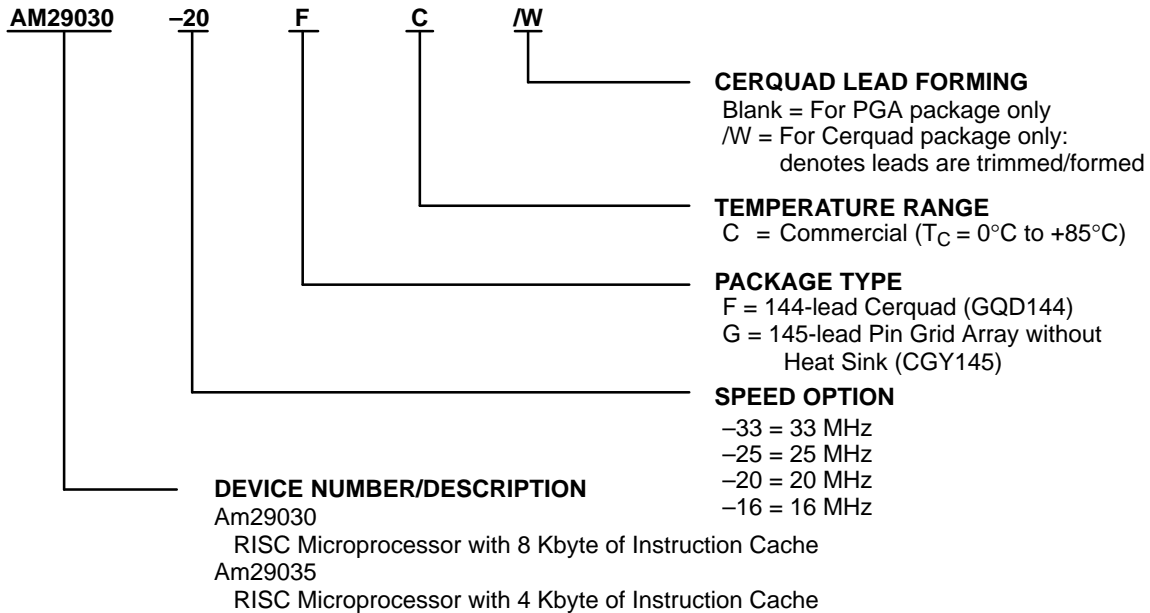

Valid Combinations	
AM29030-33 AM29030-25	GC
AM29030-20 AM29035-16	FC/W

Valid Combinations

Valid Combinations list configurations planned to be supported in volume for this device. Consult the local AMD sales office to confirm availability of specific valid combinations and to check on newly released combinations.

ABSOLUTE MAXIMUM RATINGS

Storage Temperature -65°C to +150°C
 Voltage on any Pin
 with Respect to GND -0.5 to V_{CC} +0.5 V

Stresses above those listed under ABSOLUTE MAXIMUM RATINGS may cause permanent device failure. Functionality at or above these limits is not implied. Exposure to absolute maximum ratings for extended periods may affect device reliability.

OPERATING RANGES

Commercial (C) Devices

Case Temperature (T_C) 0°C to +85°C
 Supply Voltage (V_{CC}) +4.75 to +5.25 V

Operating ranges define those limits between which the functionality of the device is guaranteed.

DC CHARACTERISTICS over COMMERCIAL operating ranges

Parameter Symbol	Parameter Description	Test Conditions	Preliminary		Unit
			Min	Max	
V _{IL}	Input Low Voltage		-0.5	0.8	V
V _{IH}	Input High Voltage		2.0	V _{CC} +0.5	V
V _{ILINCLK}	INCLK Input Low Voltage		-0.5	0.8	V
V _{IHINCLK}	INCLK Input High Voltage		2.0	V _{CC} +0.5	V
V _{ILMEMCLK}	MEMCLK Input Low Voltage		-0.5	0.8	V
V _{IHMEMCLK}	MEMCLK Input High Voltage		V _{CC} -0.8	V _{CC} +0.5	V
V _{OL}	Output Low Voltage for All Outputs except MEMCLK	I _{OL} = 3.2 mA		0.45	V
V _{OH}	Output High Voltage for All Outputs except MEMCLK	I _{OH} = -400 μA	2.4		V
I _{LI}	Input Leakage Current	0.45 V ≤ V _{IN} ≤ V _{CC} -0.45 V		±10	μA
I _{LO}	Output Leakage Current	0.45 V ≤ V _{OUT} ≤ V _{CC} -0.4 V		±10	μA
I _{CCOP}	Operating Power Supply Current	V _{CC} = 5.25 V, Outputs Floating; Holding RESET active with externally supplied MEMCLK 16.7 MHz Cerquad 20 MHz Cerquad 25 MHz PGA 33.3 MHz PGA		30 30 28 27	mA/MHz
V _{OLC}	MEMCLK Output Low Voltage	I _{OLC} = 20 mA		0.6	V
V _{OHc}	MEMCLK Output High Voltage	I _{OHc} = 20 mA	V _{CC} -0.6		V
I _{OSGND}	MEMCLK GND Short Circuit Current	V _{CC} = 5.0 V	100		mA
I _{OSVCC}	MEMCLK V _{CC} Short Circuit Current	V _{CC} = 5.0 V	100		mA

CAPACITANCE

Parameter Symbol	Parameter Description	Test Conditions	Preliminary		Unit
			Min	Max	
C _{IN}	Input Capacitance	f _C = 10 MHz		15	pF
C _{INCLK}	INCLK Input Capacitance			20	pF
C _{MEMCLK}	MEMCLK Capacitance			20	pF
C _{OUT}	Output Capacitance			20	pF
C _{I/O}	I/O Pin Capacitance			20	pF

SWITCHING CHARACTERISTICS over COMMERCIAL operating range (PGA)

No.	Parameter Description	Test Conditions	Preliminary				Unit
			25 MHz		33 MHz		
			Min	Max	Min	Max	
1	INCLK Period (T)		40	100	30	100	ns
2	INCLK High Time		16	84	14.4	85.6	ns
3	INCLK Low Time		16	84	14.4	85.6	ns
4	INCLK Rise Time		0	6	0	6	ns
5	INCLK Fall Time		0	6	0	6	ns
6	MEMCLK Delay From INCLK	Notes 1, 2	0	6	0	6	ns
7	Synchronous Output Valid Delay for signals not broken out below	MEMCLK Output MEMCLK Input	1 2	13 17	1 2	13 17	ns
7a	Synchronous Output Valid Delay for ID31-ID0	MEMCLK Output MEMCLK Input	1 2	13 17	1 2	13 17	ns
7b	Synchronous Output Valid Delay for PGMODE	MEMCLK Output MEMCLK Input	1 2	13 19	1 2	13 19	ns
8	Synchronous Output Invalid Delay for signals not broken out below	MEMCLK Output MEMCLK Input	1 2	13 17	1 2	13 17	ns
8a	Synchronous Output Invalid Delay for ID31-ID0	MEMCLK Output MEMCLK Input	1 2	13 17	1 2	13 17	ns
8b	Synchronous Output Invalid Delay for PGMODE	MEMCLK Output MEMCLK Input	1 2	13 19	1 2	13 19	ns
9	Synchronous Input Setup Time for signals not broken out below (Note 3)	MEMCLK Output MEMCLK Input MEMCLK = INCLK	17 17 12		17 17 12		ns
9a	Synchronous Input Setup Time for ID31-ID0 (Note 3)	MEMCLK Output MEMCLK Input MEMCLK = INCLK	9 9 6		9 9 6		ns
9b	Synchronous Input Setup Time for ERR (Note 3)	MEMCLK Output MEMCLK Input MEMCLK = INCLK	11 11 7		11 11 7		ns
9c	Synchronous Input Setup Time for RDN (Note 3)	MEMCLK Output MEMCLK Input MEMCLK = INCLK	18 18 12		18 18 12		ns
10	Synchronous Input Hold Time	MEMCLK Output MEMCLK= INCLK	0 2		0 2		ns
11	Setup Time for Synchronous RESET Deassertion			2		2	ns
12	Hold Time for Synchronous RESET Deassertion			5		5	ns
13	WARN Pulse Width		4T		4T		ns
14	Asynchronous Input Pulse Width		T+10		T+10		ns
15	MEMCLK High Time	MEMCLK Period=T MEMCLK Period=2T	16 T-3	84 T+3	14.4 T-3	85.6 T+3	ns
16	MEMCLK Low Time	MEMCLK Period=T MEMCLK Period=2T	16 T-3	84 T+3	14.4 T-3	85.6 T+3	ns
17	MEMCLK Rise Time		0	5	0	5	ns
18	MEMCLK Fall Time		0	5	0	5	ns

Notes:

- MEMCLK as an input is always CMOS level.
- MEMCLK can drive an external load of 150 pF.
- The input setup times with MEMCLK used as an input are improved if MEMCLK and INCLK are tied to the same clock input. This is possible only if the processor and bus operate at the same frequency.
- Except where noted, measurement conditions are the same as the Am29000 microprocessor.
- All output valid delays are measured with $V_{OL} = 1.5\text{ V}$ and $V_{OH} = 1.5\text{ V}$.

SWITCHING CHARACTERISTICS over COMMERCIAL operating range (Cerquad)

No.	Parameter Description	Test Conditions	Preliminary Information				Unit
			16 MHz		20 MHz		
			Min	Max	Min	Max	
1	INCLK Period (T)		60	100	50	100	ns
2	INCLK High Time		24	76	20	80	ns
3	INCLK Low Time		24	76	20	80	ns
4	INCLK Rise Time		0	6	0	6	ns
5	INCLK Fall Time		0	6	0	6	ns
6	MEMCLK Delay From INCLK	Notes 1, 2	0	6	0	6	ns
7	Synchronous Output Valid Delay for signal not broken out below	MEMCLK Output MEMCLK Input	1 2	20 24	1 2	18 22	ns
7a	Synchronous Output Valid Delay for ID31-ID0	MEMCLK Output MEMCLK Input	1 2	22 26	1 2	20 24	ns
7b	Synchronous Output Valid Delay for PGMODE	MEMCLK Output MEMCLK Input	1 2	22 26	1 2	20 24	ns
8	Synchronous Output Invalid Delay for signals not broken out below	MEMCLK Output MEMCLK Input	1 2	20 24	1 2	18 22	ns
8a	Synchronous Output Invalid Delay for ID31-ID0	MEMCLK Output MEMCLK Input	1 2	22 26	1 2	20 24	ns
8b	Synchronous Output Invalid Delay for PGMODE	MEMCLK Output MEMCLK Input	1 2	22 26	1 2	22 26	ns
9	Synchronous Input Setup Time for signals not broken out below (Note 3)	MEMCLK Output MEMCLK Input MEMCLK = INCLK	21 21 17		19 19 15		ns
9a	Synchronous Input Setup Time for ID31-ID0 (Note 3)	MEMCLK Output MEMCLK Input MEMCLK = INCLK	17 17 13		15 15 11		ns
9b	Synchronous Input Setup Time for ERR (Note 3)	MEMCLK Output MEMCLK Input MEMCLK = INCLK	17 17 13		15 15 11		ns
9c	Synchronous Input Setup Time for RDN (Note 3)	MEMCLK Output MEMCLK Input MEMCLK = INCLK	21 21 17		19 19 15		ns
10	Synchronous Input Hold Time	MEMCLK Output MEMCLK Input	2 3		2 3		ns
11	Setup Time for Synchronous RESET Deassertion			4		4	ns
12	Hold Time for Synchronous RESET Deassertion			7		7	ns
13	WARN Pulse Width		4T		4T		ns
14	Asynchronous Input Pulse Width		T+10		T+10		ns
15	MEMCLK High Time	MEMCLK Period=T MEMCLK Period=2T	24 T-3	76 T+3	20 T-3	80 T+3	ns
16	MEMCLK Low Time	MEMCLK Period=T MEMCLK Period=2T	24 T-3	76 T+3	20 T-3	80 T+3	ns
17	MEMCLK Rise Time		0	6	0	6	ns
18	MEMCLK Fall Time		0	6	0	6	ns

Notes:

- MEMCLK as an input is always CMOS level.
- MEMCLK can drive an external load of 150 pF.
- The input setup times with MEMCLK used as an input are improved if MEMCLK and INCLK are tied to the same clock input. This is possible only if the processor and bus operate at the same frequency.
- Except where noted, measurement conditions are the same as the Am29000 microprocessor.
- All output valid delays are measured with $V_{OL} = 1.5\text{ V}$ and $V_{OH} = 1.5\text{ V}$.

SWITCHING WAVEFORMS

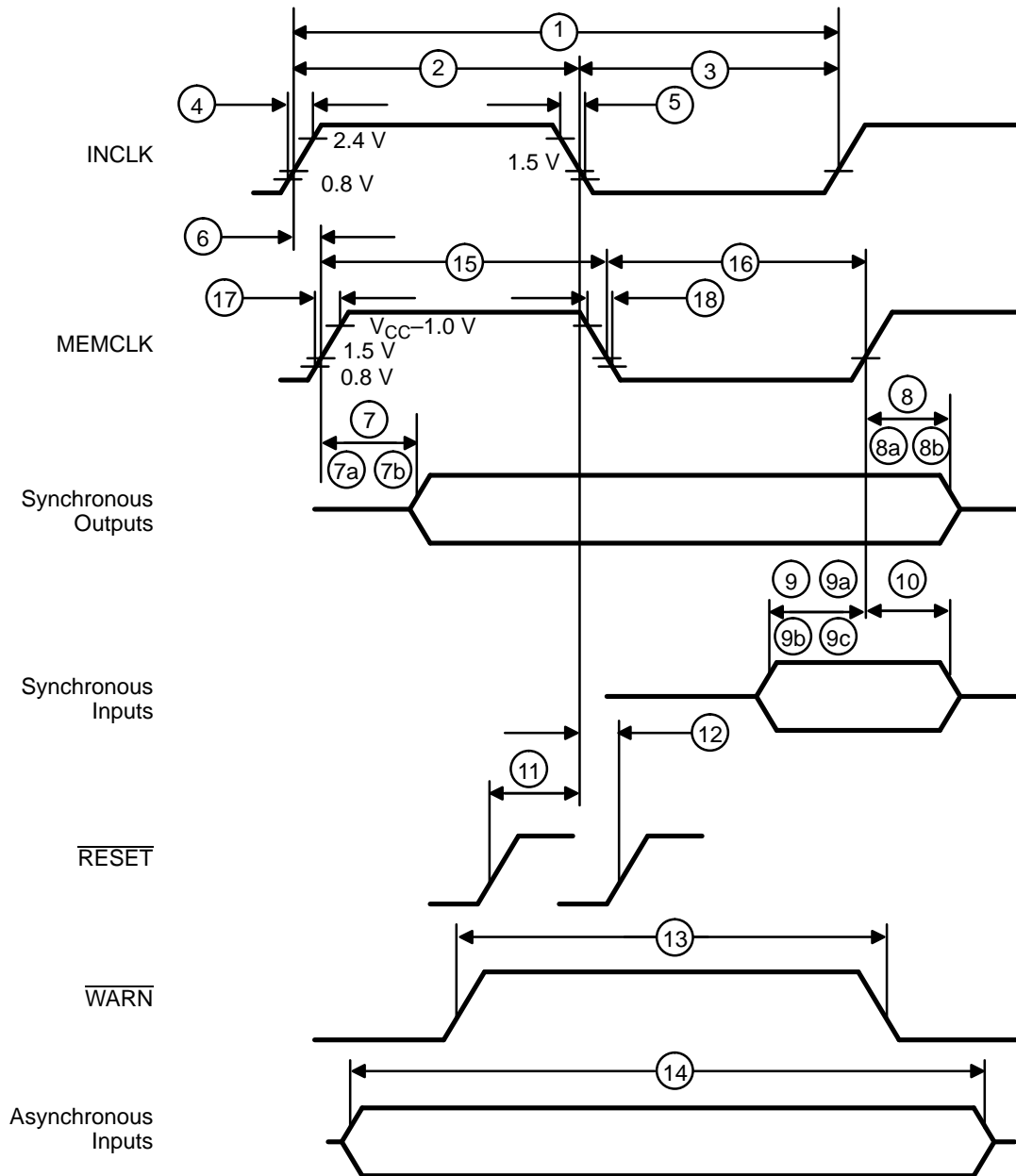

Capacitive Output Delays

For loads greater than 80 pF

The following table describes the additional output delays for capacitive loads greater than 80 pF. Values in the Maximum Additional Delay column should be added

to the value listed in the Switching Characteristics table. For loads less than or equal to 80 pF, refer to the delays listed in the Switching Characteristics table. This table applies to the PGA package only.

No.	Parameter Description	Preliminary	
		Total External Capacitance (pF)	Maximum Additional Delay (ns)
7	Synchronous MEMCLK Output Valid Delay	100 pF	+1 ns
		150 pF	+2 ns
		200 pF	+4 ns
		250 pF	+6 ns
		300 pF	+8 ns
7a	Synchronous MEMCLK Output Valid Delay for ID31-ID0	100 pF	+1 ns
		150 pF	+6 ns
		200 pF	+10 ns
		250 pF	+15 ns
		300 pF	+19 ns

SWITCHING TEST CIRCUIT

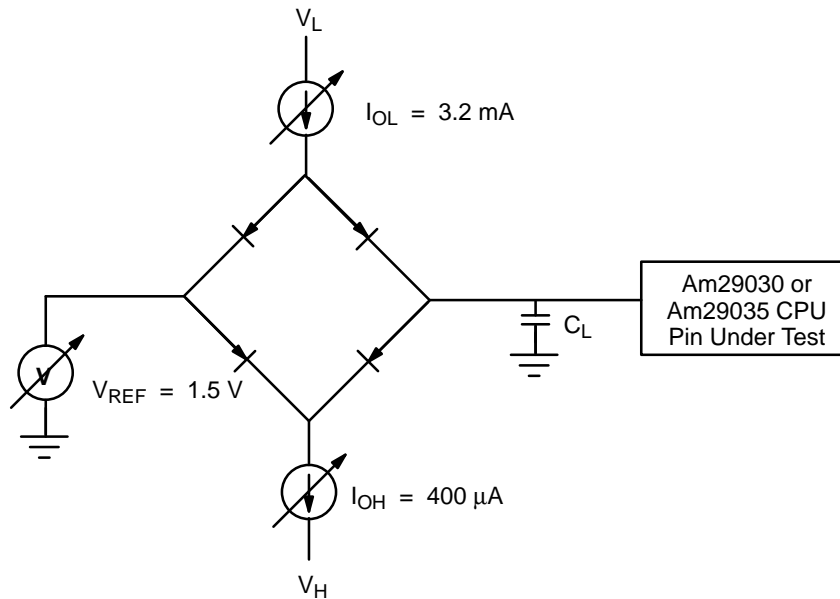

Note: C_L is guaranteed to 80 pF. For capacitive loading greater than 80 pF, refer to the Capacitive Output Delay table.

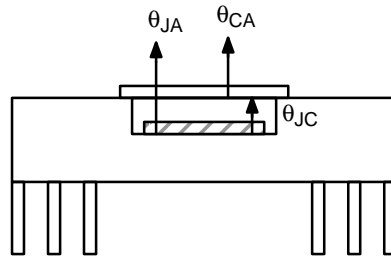
THERMAL CHARACTERISTICS**Pin-Grid-Array Package**

$$\theta_{JA} = \theta_{JC} + \theta_{CA}$$

Thermal Resistance – °C/Watt

Pin-Grid-Array Package

		Airflow (LFPM)			
		0	150	300	500
θ_{JC}	Junction-to-Case	3	–	–	–
θ_{CA}	Case-to-Ambient	20	18	16	13

Cerquad Package

		Airflow (LFPM)			
		0	150	300	500
θ_{JC}	Junction-to-Case	7.5	–	–	–
θ_{CA}	Case-to-Ambient	20.8	18.7	16.4	13.3

PHYSICAL DIMENSIONS

GQD 144 — Cerquad Trimmed and Formed (metric unit)

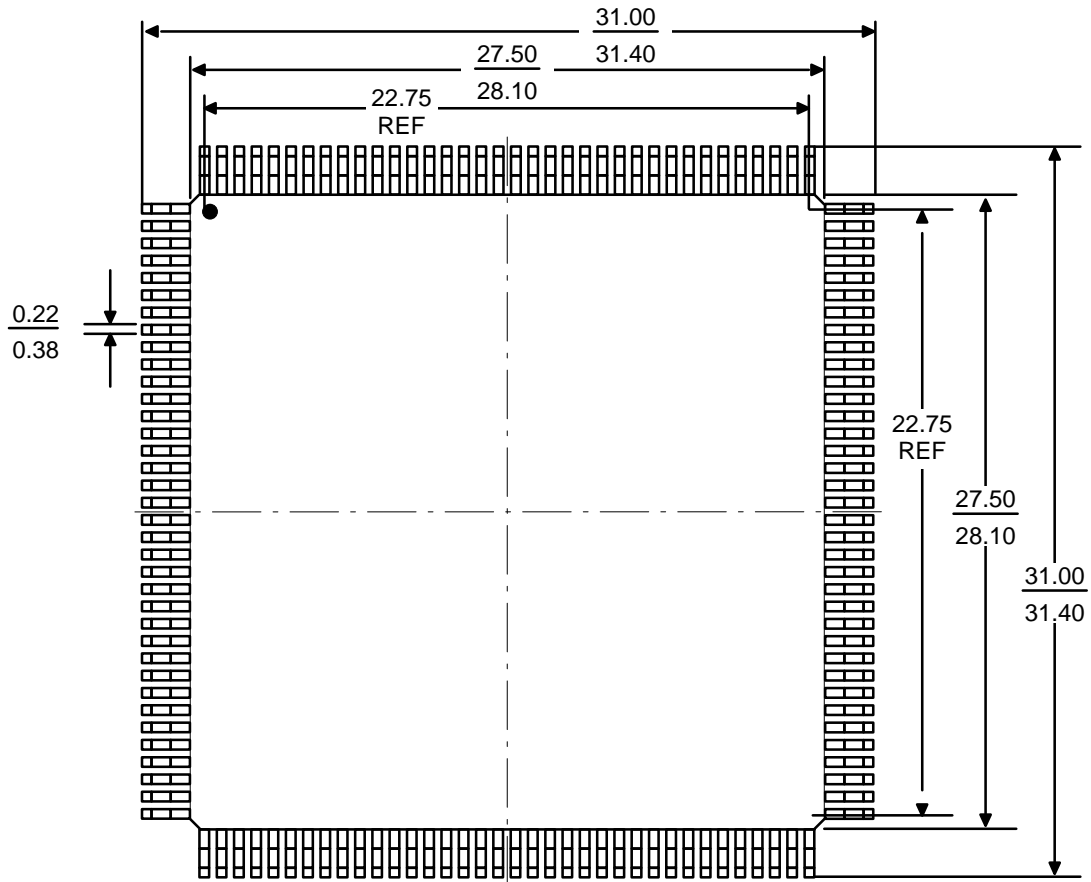

Top View

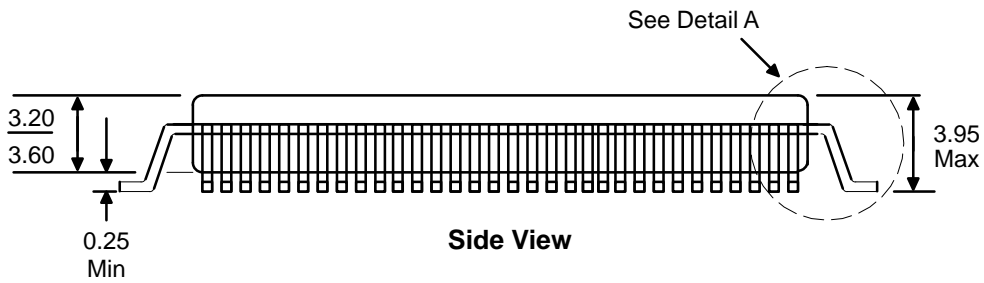

Side View

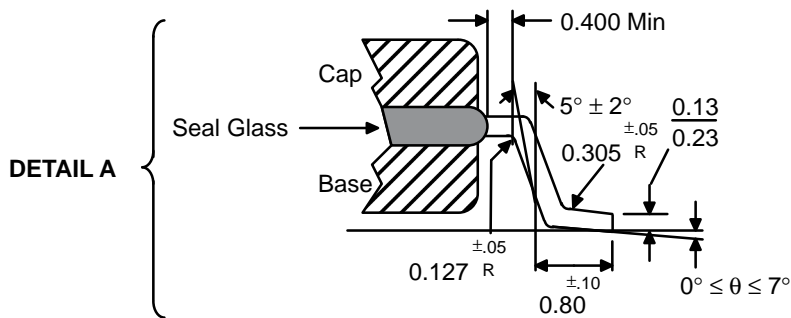

20000A
CK 64
08/03/93 MH

CGY 145 – Pin Grid Array (PGA)

This diagram is not currently available in this Acrobat file. To order a printed document that contains this information, please call AMD's Facts-On-Demand™ fax information service at 800–222–9323, or call the literature hotline at 512–602–5651 (direct dial worldwide) or 800–292–9263 (toll-free for U.S.)

Trademarks

AMD, Am29000 and Fusion29K are registered trademarks; and 29K, Am29005, Am29030, Am29035, Am29040, Am29050, Am29200, Am29202, Am29205, Am29240, Am29243, Am29245, XRAY29K, MiniMON29K, and Scalable Clocking are trademarks of Advanced Micro Devices, Inc.

High C is a registered trademark of MetaWare, Inc. Product names used in this publication are for identification purposes only and may be trademarks of their respective companies.

© 1993 Advanced Micro Devices, Inc.