

### POWER MANAGEMENT

#### Description

The SC1462 is a versatile charge pump designed for use in battery operated power supply applications over the wide input range of 1.65 to 5.5 volts. A simple, low quiescent current charge pump doubler can be implemented without costly inductors or capacitors. Internal MOSFETs and control circuitry eliminate the need for costly board space and design time. The small 6 lead SOT-23 package helps minimize board space.

The SC1462 charge pump can be used for applications that require up to 80mA of output current with  $V_{IN} = 2.5V$  to 5.5V. Typical dropout voltage  $(2 \times V_{IN}) - V_{OUT}$  is shown below for several values of  $V_{IN}$ .

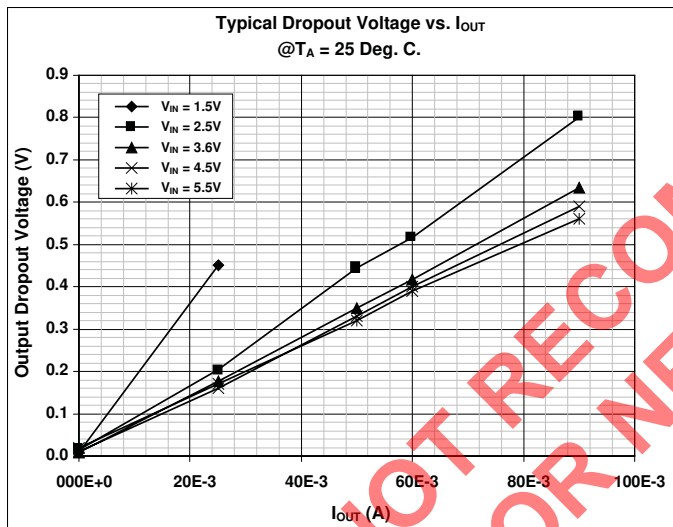

#### Features

- ◆ Input supply voltage range of 1.65V to 5.5V
- ◆ Small size - 6 pin SOT-23 package
- ◆ Typical efficiency of :
  - 91% @  $V_{IN} = 2.5V, I_{OUT} = 45mA$
  - 94% @  $V_{IN} = 3.6V, I_{OUT} = 55mA$
- ◆ Short circuit and over-temperature protection
- ◆ 140 $\mu$ A typical input current @ no load
- ◆ Shutdown current <1 $\mu$ A
- ◆ Designed to work with ceramic or tantalum capacitors
- ◆ Fixed frequency of 160kHz
- ◆ All specifications rated over full temperature range (-40 $^{\circ}$ C to 85 $^{\circ}$ C)

#### Applications

- ◆ Cellular phones
- ◆ Handheld devices
- ◆ LCD Display

#### Typical Application Circuit

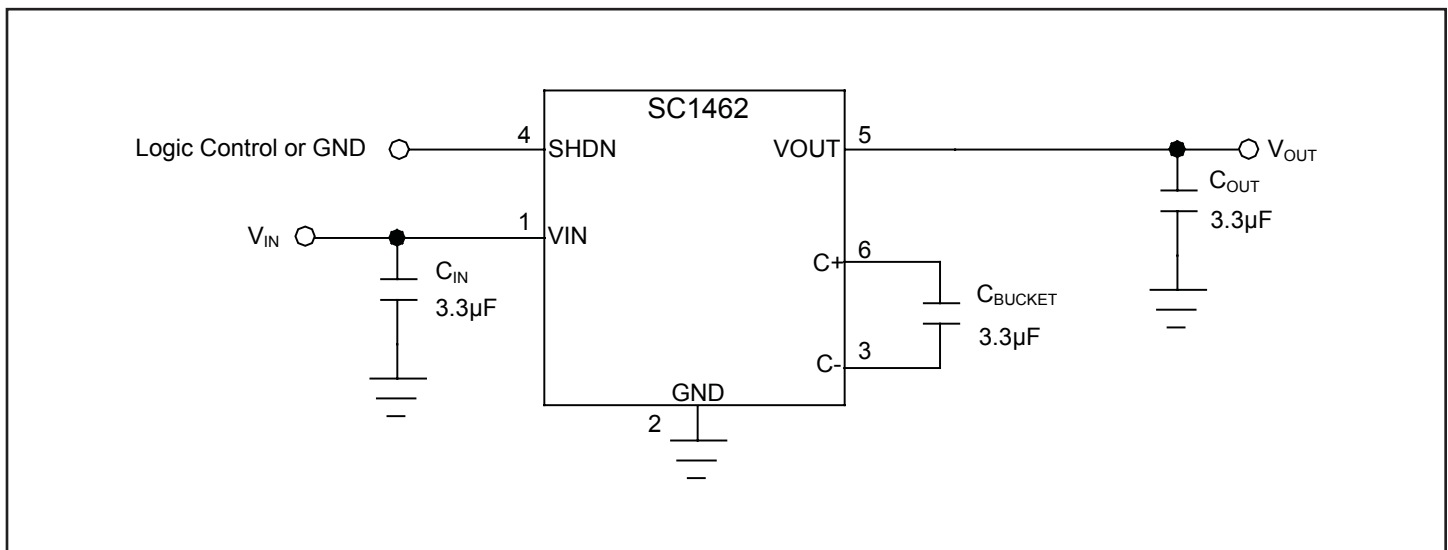

**POWER MANAGEMENT**

**Absolute Maximum Ratings<sup>(1)</sup>**

Exceeding the specifications below may result in permanent damage to the device or device malfunction. Operation outside of the parameters specified in the Electrical Characteristics section is not implied.

Parameter	Symbol	Maximum	Units
Supply Voltage	$V_{IN}$	-0.3 to +6.0	V
Output Voltage	$V_{OUT}$	-0.3 to +12	V
$V_{OUT}$ Short Circuit Duration	SC	Indefinite	
Thermal Resistance Junction to Ambient <sup>(2)</sup>	$\theta_{JA}$	230	°C/W
Operating Ambient Temperature Range	$T_A$	-40 to +85	°C
Junction Temperature Range	$T_J$	-40 to +125	°C
Storage Temperature Range	$T_{STG}$	-65 to +150	°C
Peak IR Flow Temperature, SC1462ISKTR	$T_{LEAD}$	240	°C
Peak IR Flow Temperature, SC1462ISKTRT	$T_{LEAD}$	260	°C

Notes:

- 1) This device is ESD sensitive. Use of standard ESD handling precautions is required.
- 2) Calculated from package in still air, mounted to 3" x 4.5", 4 layer FR4 PCB with thermal vias under the exposed pad as per JESD51 standards.

**Electrical Characteristics**

Unless specified:

$T_A = -40\text{ }^{\circ}\text{C}$  to  $85\text{ }^{\circ}\text{C}$ , SHDN = GND,  $1.65\text{V} \leq V_{IN} \leq 5.5\text{V}$ , Frequency = 160kHz,  $C_{IN} = C_{OUT} = C_{BUCKET} = 3.3\mu\text{F}$  (ESR = 0.3Ω).

Parameter	Symbol	Conditions	Min	Typ	Max	Units
Input Supply Voltage	$V_{IN}$		1.65		5.5	V
Input Supply Current	$I_{IN}$	$I_{OUT} = 0, V_{IN} = 2.5\text{V}$		140	260	μA
		$I_{OUT} = 0, V_{IN} = 3.6\text{V}$		200	400	μA
		SHDN = $V_{IN}$		0.1	1	μA
Output Resistance <sup>(1)</sup>	$R_{OUT}$	$V_{IN} = 2.5\text{V}$		9.5	13.5	Ω
Output Resistance <sup>(1)</sup>	$R_{OUT}$	$V_{IN} = 3.6\text{V}$		7.5	10.5	Ω
Total Switch Resistance <sup>(2)</sup>	$R_{SW}$	$V_{IN} = 2.5\text{V}$		3	4.5	Ω
Total Switch Resistance <sup>(2)</sup>	$R_{SW}$	$V_{IN} = 3.6\text{V}$		2	3	Ω
Output Current	$I_{OUT}$	$V_{IN} = 2.5\text{V}$			80	mA
		$V_{IN} = 3.6\text{V}$			80	mA
Oscillator Frequency	$f_{OSC}$		100	160	200	kHz

**POWER MANAGEMENT**

**Electrical Characteristics (Cont.)**

Parameter	Symbol	Conditions	Min	Typ	Max	Units
Short Circuit Current	$I_{SC}$	$V_{OUT} = 0V$		200		mA
Output Ripple (pk-pk) <sup>(3)(4)</sup>	$V_R$	$I_{OUT} = 45mA, V_{IN} = 2.5V$		75		mV
Power Efficiency <sup>(3)</sup>	$\eta$	$I_{OUT} = 45mA, V_{IN} = 2.5V$	86			%
Maximum Output Voltage <sup>(4)</sup>	$V_{OUT}$	$I_{OUT} = 0mA$			$2 \times V_{IN}$	V
Time to Regulation at Turn-On <sup>(5)</sup>	$t_{ON}$	$I_{OUT} = 0$ to 60mA, $V_{IN} = 3.6V$		500		$\mu s$
Input High Threshold	$V_{IN}$	SHDN pin, $2.5V \leq V_{IN} \leq 5.5V$	1.6			V
Input Low Threshold	$V_{IL}$	SHDN pin, $2.5V \leq V_{IN} \leq 5.5V$			0.4	V
Over-Temperature Protection <sup>(4)</sup>	$T_{OT}$			140		$^{\circ}C$
Over-Temperature Hysteresis <sup>(4)</sup>		Hysteresis		20		$^{\circ}C$

Notes:

- 1) The internal switch resistance, the capacitor ESR and the oscillator's switching frequency all contribute to  $R_{OUT}$ . See the CAPACITOR SELECTION section on Page 6 for information on applying the  $R_{OUT}$  specification.
- 2) The parameter  $R_{SW}$  is equal to the total resistance of all 4 internal switches. See the CAPACITOR SELECTION section for information on applying the  $R_{SW}$  specification. The parameter was calculated from actual output resistance and the equation on Page 6 for  $R_{OUT}$ .
- 3) All electrical characteristics are for the Typical Application Circuit on Page 1.
- 4) Guaranteed by design.
- 5) Soft start functionality is performed along with short circuit protection. If  $V_{OUT}$  is less than  $V_{IN} - 200mV$ , then all switches are turned off and  $V_{OUT}$  is charged with a 200mA current source from  $V_{IN}$ . When  $V_{OUT}$  reaches  $V_{IN} - 200mV$  all switches are enabled.

NOT RECOMMENDED FOR NEW DESIGN

POWER MANAGEMENT

Pin Configuration

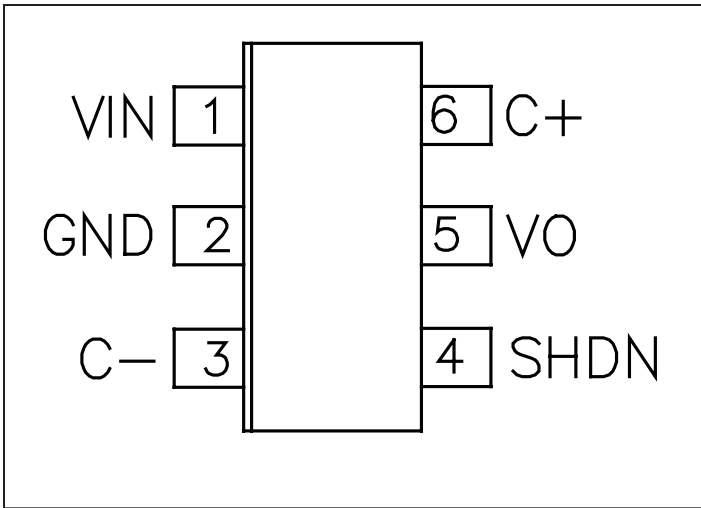

Ordering Information

DEVICE <sup>(1)</sup>	PACKAGE
SC1462ISKTR	SOT-23-6
SC1462ISKTRT <sup>(2)</sup>	SOT-23-6

Notes:

- 1) Available in tape and reel only. A reel contains 3,000 devices.
- 2) This Pb free device is WEEE and RoHS compliant.

Pin Descriptions

Pin#	Pin Name	Pin Function
1	VIN	Supply input voltage.
2	GND	Ground.
3	C-	This pin should be connected to the negative terminal of the external charging capacitor.
4	SHDN	Shutdown pin. When this pin is connected to $V_{IN}$ , the device enters sleep mode.
5	VO	Voltage output.
6	C+	This pin should be connected to the positive terminal of the external charging capacitor.

Block Diagram

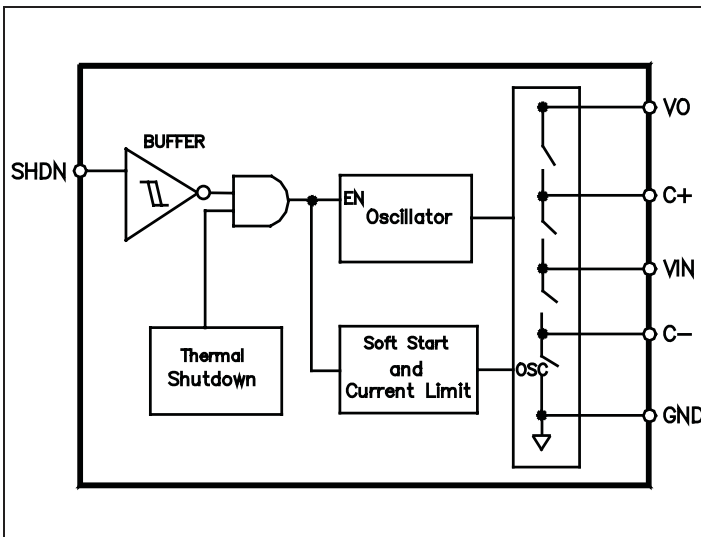

Marking Information

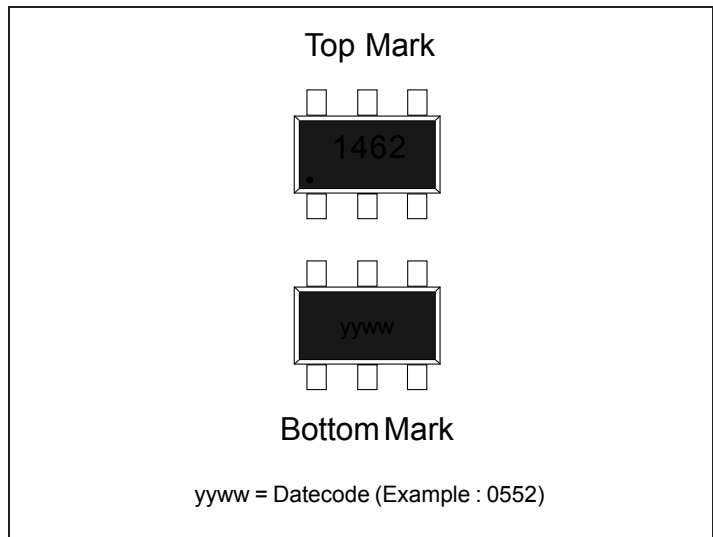

POWER MANAGEMENT

Applications Information

**Theory of Operation**

The SC1462 utilizes a switched capacitor charge pump to generate an output voltage approximately  $2 \times V_{IN}$ .

An internal oscillator generates two out of phase fixed frequency clock signals which turn on and off internal MOS-FET switches. During phase 1, the flying charge pump capacitor is charged to  $V_{IN}$  through switches S1 and S2. During phase 2, the flying charge pump capacitor is connected in series with the input voltage via S3 and S4, producing an output voltage.

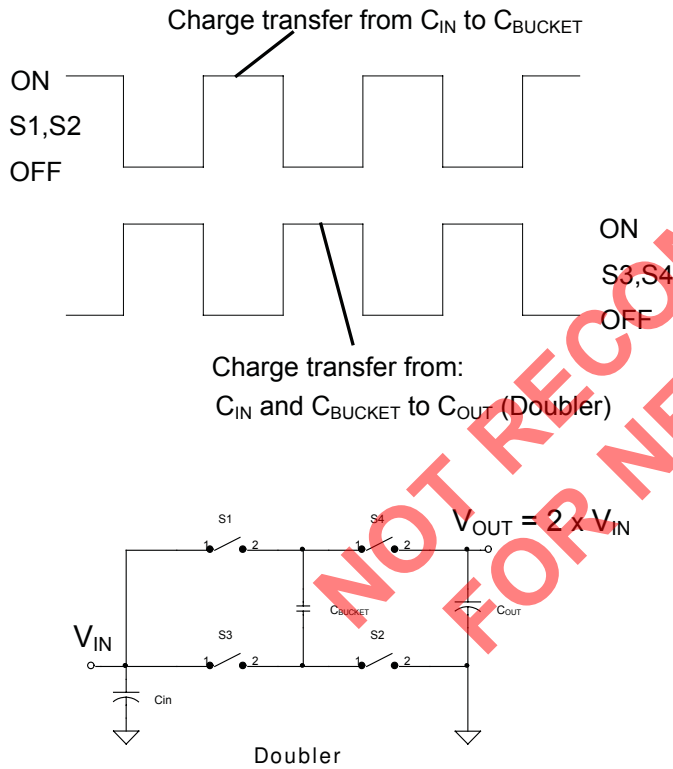

If  $V_{OUT}$  is less than  $V_{IN} - 200mV$ , then all switches are turned off and  $V_{OUT}$  is charged with a 200mA current source from  $V_{IN}$ . When  $V_{OUT}$  reaches  $V_{IN} - 200mV$ , the current source is disconnected from output and the charge pump circuitry is enabled again.

**Output Current**

The dropout voltage for a charge pump doubler is defined as  $(2 \times V_{IN}) - V_{OUT}$ . The maximum output current is usually specified as that which will not cause the dropout voltage to exceed the requirements of the application. The calculation of the dropout voltage is given in the capacitor selection section on Page 6. Typical dropout voltages versus  $I_{OUT}$  are graphed on Page 8.

**Thermal Shutdown**

The thermal shutdown circuit provides added protection to the SC1462. During a  $V_{OUT}$  short circuit condition or if the load is excessive, the over-temperature circuitry will shut down the charge pump if the junction temperature exceeds approximately  $140^{\circ}C$ . The charge pump is enabled only if the junction temperature drops to approximately  $120^{\circ}C$ . The SC1462 will cycle in and out of thermal shut down until the short circuit or the excessive load condition on  $V_{OUT}$  is removed, thereby improving device reliability. The junction temperature can be calculated from the following formula if the ambient temperature ( $T_A$ ) and the charge pump power dissipation ( $P_{DISS}$ ) are known.

$$T_J = T_A + P_{DISS} \times \theta_{JA} ; \theta_{JA} = 230^{\circ}C/W$$

**Short Circuit/Soft-Start**

An internal current limit and soft-start circuit provides protection against output short circuit and limits large current spikes generated during the initial start-up to charge output capacitor.

**POWER MANAGEMENT**

**Applications Information (Cont.)**

**Capacitor Selection**

Capacitor selection is based on both the maximum acceptable ripple voltage and the maximum tolerable drop at the output.

**Ripple**

The peak-to-peak output ripple voltage is dependent on the following factors:

- 1) Oscillator frequency
- 2) ESR of  $C_{OUT}$
- 3) Capacitance value of  $C_{OUT}$

Item 1 is fixed and depend on the charge pump device used. Item 2, and 3 can be optimized for best performance and reduction of the output ripple.

The following formula could be used for an approximation for  $V_{OUT\_RIPPLE}$ \*

$$V_{OUT\_RIPPLE} = \frac{I_{OUT}}{2 \times f_{OSC} \times C_{OUT}} + 2 \times I \times ESR\_C_{OUT}$$

**$V_{OUT}$  Drop**

The voltage drop at the output is specified with the following equation:

$$V_{OUT\_DROP} = I_{OUT} \times R_{OUT}$$

$R_{OUT}$  is dependent on the following factors:

- 1) Oscillator frequency
- 2) ESR of  $C_{OUT}$  &  $C_{BUCKET}$
- 3) Capacitance value of  $C_{OUT}$  and  $C_{BUCKET}$
- 4) Internal switch resistance ( $R_{SW}$  = Total of all 4 switch resistances).

A good approximation for calculating the output resistance is shown below.

$$R_{OUT} = \frac{1}{f_{OSC} \times C_{BUCKET}} + 2 \times R_{SW} + 4 \times ESR\_C_{BUCKET} + ESR\_C_{OUT}$$

This equation can be used to calculate  $C_{BUCKET}$  for a specific  $V_{OUT}$  when  $V_{IN}$  and  $I_{OUT}$  are known. The maximum value for the  $R_{SW}$  from the Electrical Characteristics section on Page 2 should be used in order to find a worst-case number.

**Layout Consideration**

Standard power board layout should be followed to ensure proper operation. Any stray inductance should be minimized, this can be achieved by using large power planes or traces, and reducing the distances between input, output and the load. All components should be placed as close as possible to the SC1462.

The following table shows typical capacitor characteristics.

Component	ESR( $\Omega$ )	ESL(nH)
0.1 $\mu$ F Ceramic 0603 Package	0.050	1.60
1.0 $\mu$ F Ceramic 1206 Package	0.040	0.47
10 $\mu$ F Ceramic 0603 Package	0.075	0.50
47 $\mu$ F Ceramic, 16V Tantalum D case	0.100	0.60
330 $\mu$ F, 6.3V "OSCON"	0.025	2.50
330 $\mu$ F, 16V AL. Electrolytic	0.143	2.37
820 $\mu$ F, 4V "OSCON"	0.012	2.50
1000 $\mu$ F, 10V Al. Electrolytic	0.053	5.00

POWER MANAGEMENT

Applications Information (Cont.)

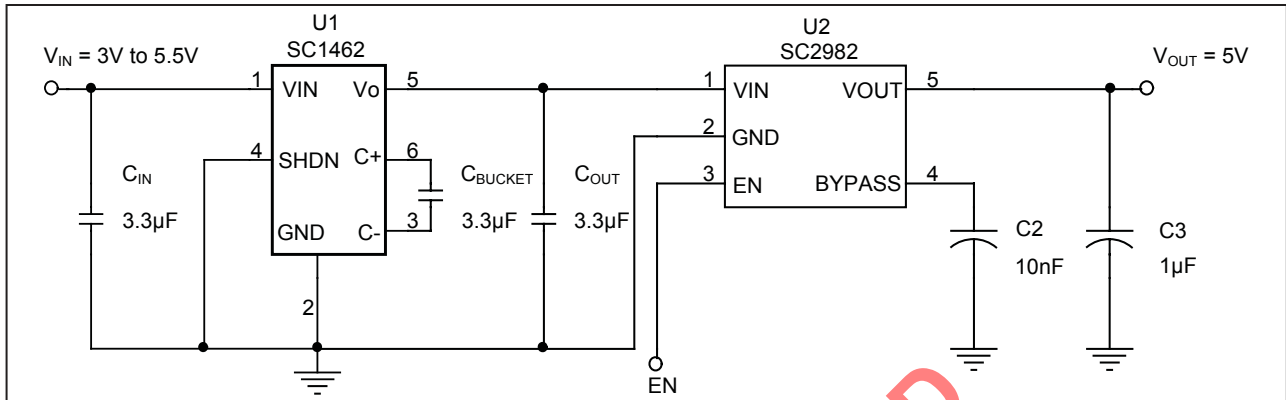

5 Volts Fixed Output Voltage

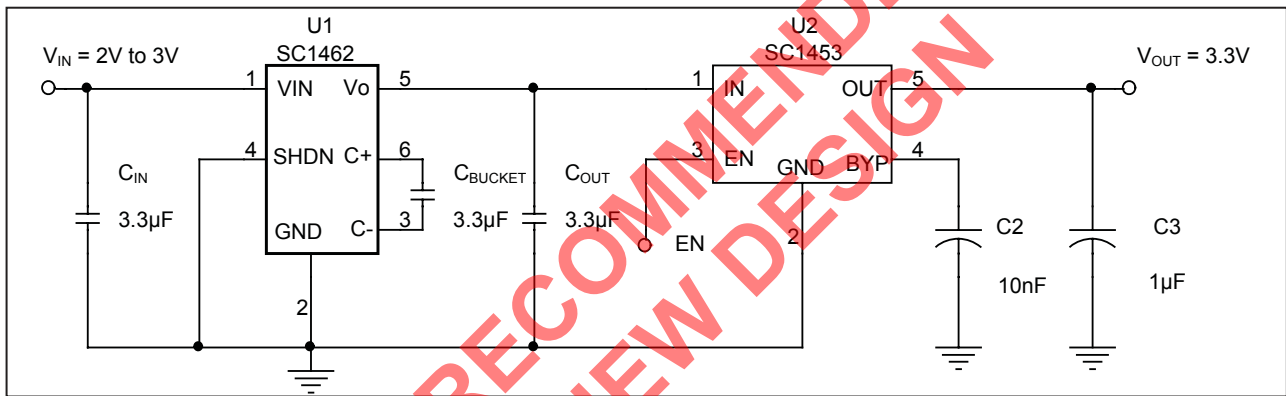

3.3 Volts Fixed Output Voltage

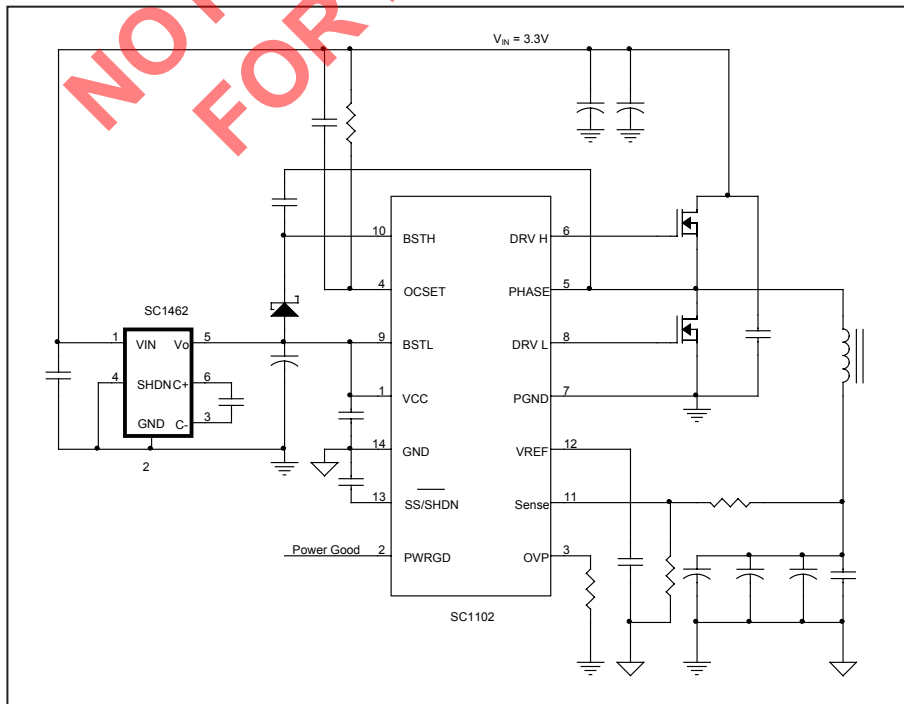

(3.3V Input Supply) Battery Operated Synchronous Buck Converter

POWER MANAGEMENT

Typical Characteristics

Typical  $I_{IN}$  vs.  $V_{IN}$ ,  $I_{OUT} = 0mA$

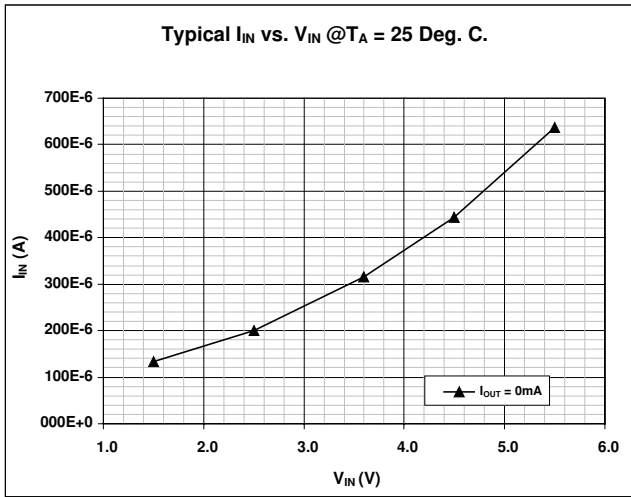

Typical Dropout vs.  $I_{OUT}$

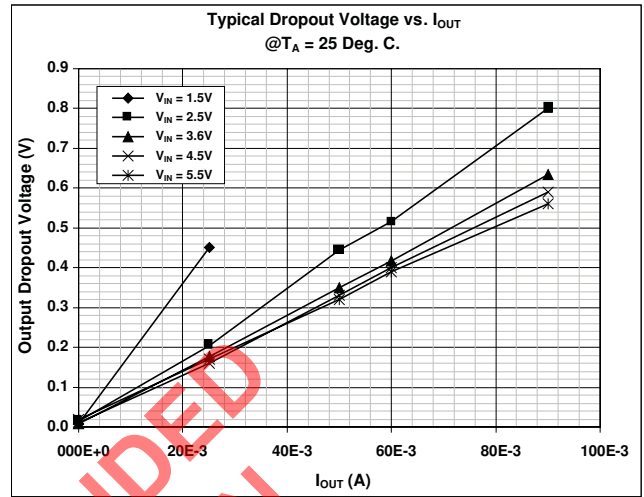

Typical  $I_{IN}$  vs.  $T_A$ ,  $I_{OUT} = 0mA$

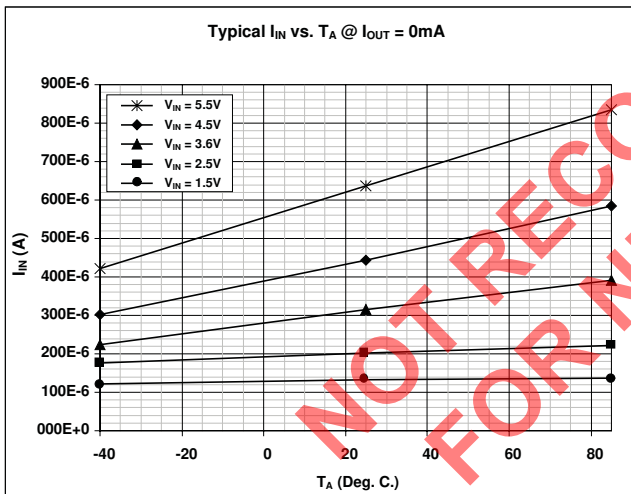

Typical Dropout vs.  $T_A$

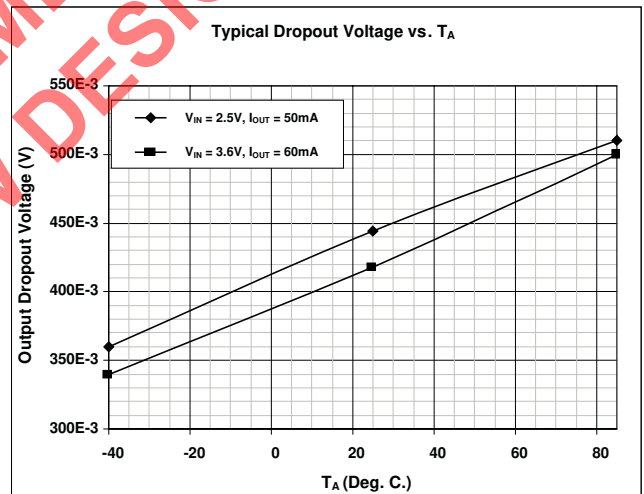

Typical Efficiency vs.  $I_{OUT}$

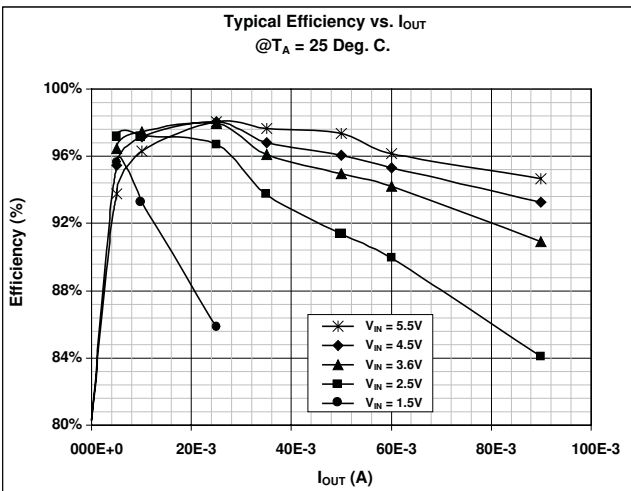

Typical Output Ripple

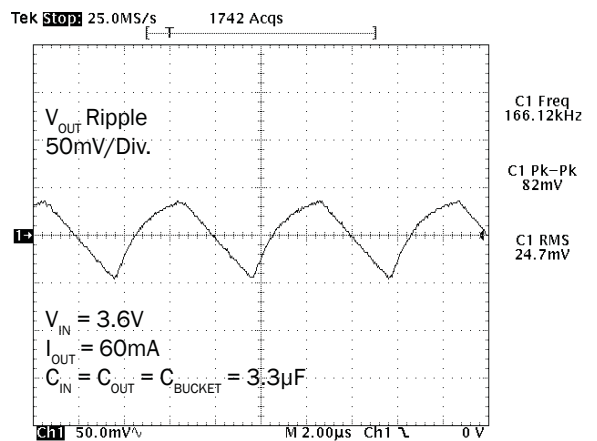



POWER MANAGEMENT

Outline Drawing - SOT-23-6L

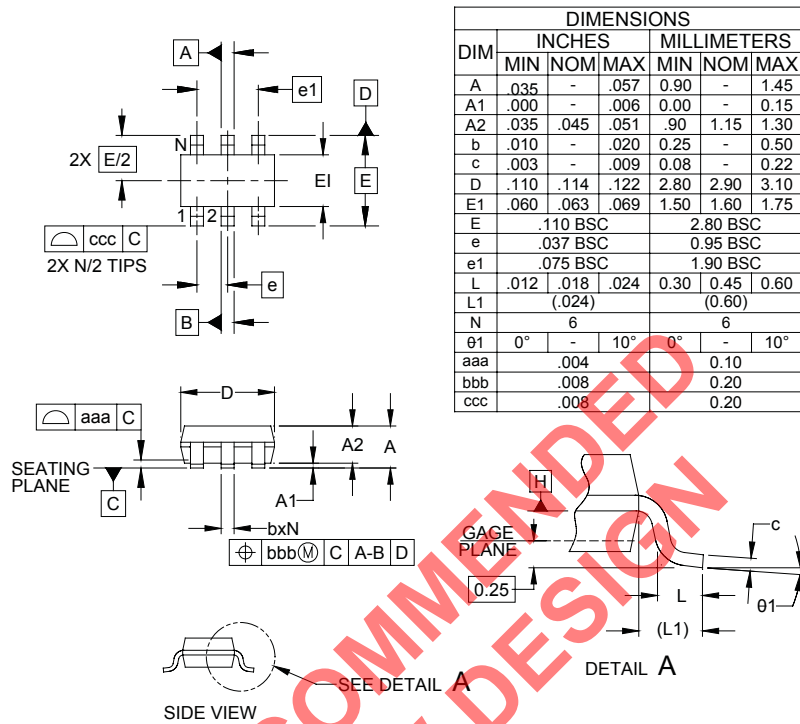

DIM	INCHES			MILLIMETERS		
	MIN	NOM	MAX	MIN	NOM	MAX
A	.035	-	.057	0.90	-	1.45
A1	.000	-	.006	0.00	-	0.15
A2	.035	.045	.051	.90	1.15	1.30
b	.010	-	.020	0.25	-	0.50
c	.003	-	.009	0.08	-	0.22
D	.110	.114	.122	2.80	2.90	3.10
E1	.060	.063	.069	1.50	1.60	1.75
E	.110 BSC			2.80 BSC		
e	.037 BSC			0.95 BSC		
e1	.075 BSC			1.90 BSC		
L	.012	.018	.024	0.30	0.45	0.60
L1	(.024)			(0.60)		
N	6			6		
θ1	0°	-	10°	0°	-	10°
aaa	.004			0.10		
bbb	.008			0.20		
ccc	.008			0.20		

NOTES:

1. CONTROLLING DIMENSIONS ARE IN MILLIMETERS (ANGLES IN DEGREES).
2. DATUMS  $\boxed{-A-}$  AND  $\boxed{-B-}$  TO BE DETERMINED AT DATUM PLANE  $\boxed{-H-}$ .
3. DIMENSIONS "E1" AND "D" DO NOT INCLUDE MOLD FLASH, PROTRUSIONS OR GATE BURRS.

NOT RECOMMENDED FOR NEW DESIGN

POWER MANAGEMENT

Land Pattern - SOT-23-6L

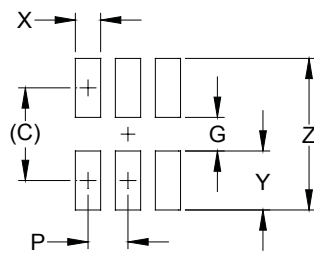

DIMENSIONS		
DIM	INCHES	MILLIMETERS
C	(.098)	(2.50)
G	.055	1.40
P	.037	0.95
X	.024	0.60
Y	.043	1.10
Z	.141	3.60

NOTES:

1. THIS LAND PATTERN IS FOR REFERENCE PURPOSES ONLY. CONSULT YOUR MANUFACTURING GROUP TO ENSURE YOUR COMPANY'S MANUFACTURING GUIDELINES ARE MET.

NOT RECOMMENDED FOR NEW DESIGN

Contact Information

Semtech Corporation  
 Power Management Products Division  
 200 Flynn Road, Camarillo, CA 93012  
 Phone: (805) 498-2111 FAX (805) 498-3804