

NOTES:

1. MATERIALS AND FINISHES:

- HEX NUT - BRASS, NICKEL PLATING
- LOCK WASHER - PHOSPHOR BRONZE, NICKEL PLATING
- FERRULE - BRASS, NICKEL PLATING
- GASKET - SILICONE RUBBER, RED
- BODY - BRASS, NICKEL PLATING
- CONTACT - PHOSPHOR BRONZE & BRASS, GOLD PLATING
- INSULATOR - PTFE, NATURAL

2. ELECTRICAL:

- A. IMPEDANCE: 50 OHM, NOMINAL
- B. FREQUENCY RANGE: 0-4 GHz
- C. D.W.V: 1200 VRMS, MIN.

3. MECHANICAL:

- A. DURABILITY: 500 CYCLES MIN.
- B. TEMPERATURE RANGE: -65°C TO +165°C

4. CRIMPED FERRULE HEX CRIMP SIZE .178"

5. CONTACT PIN TO SOLDER

6 SHOWS CABLE ENTRY DIMENSIONS.

THIRD ANGLE PROJ.

REVISIONS

REV	DESCRIPTION	DATE	ECO	APPR
NC	INITIAL RELEASE	23-Nov-08	----	GRS
A	SYNC, REDRAWN IN THE PRO/E	09-Nov-16	02365	BW
B	REMOVE RG-174 & RG316	04-FEB-19	10563	MRM

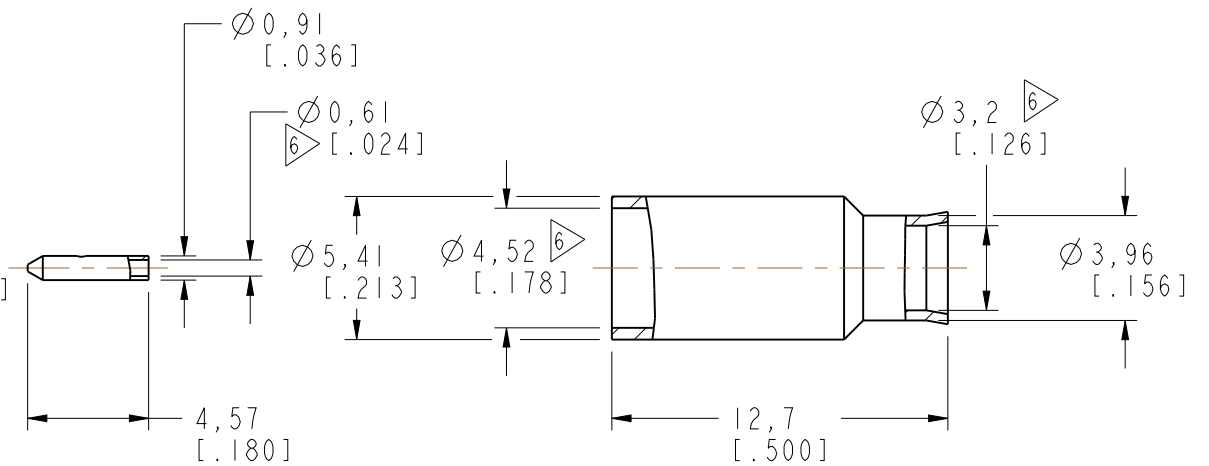
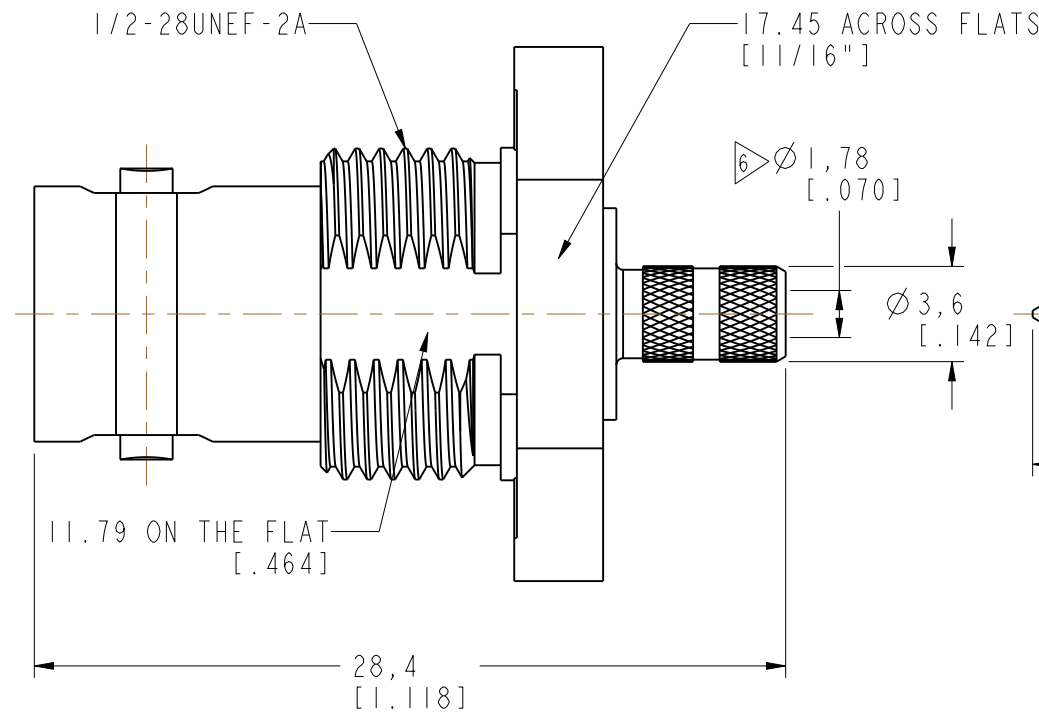
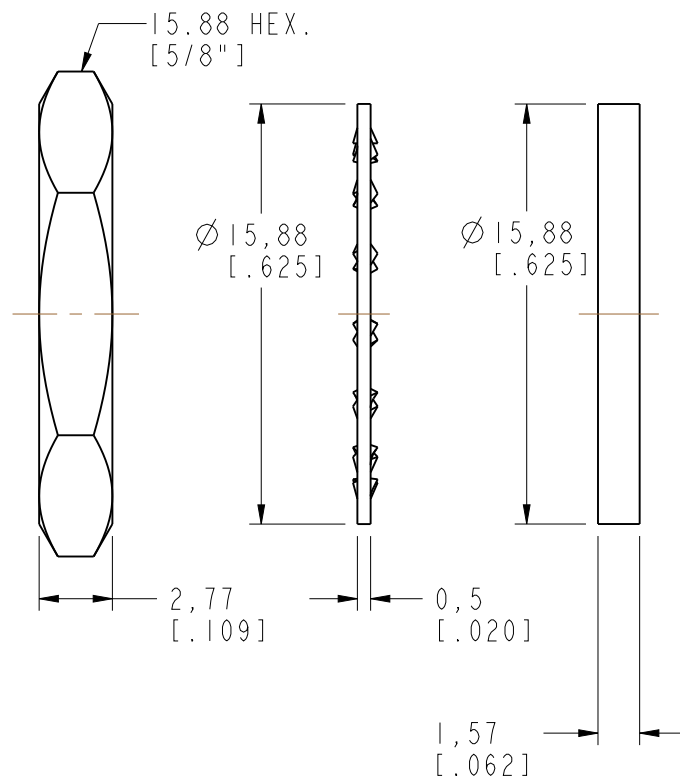
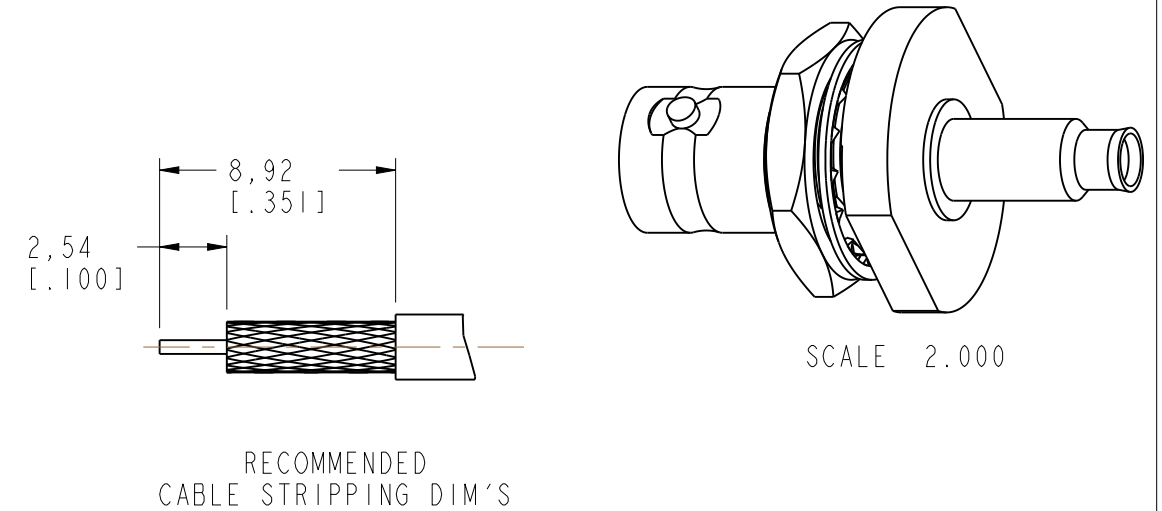
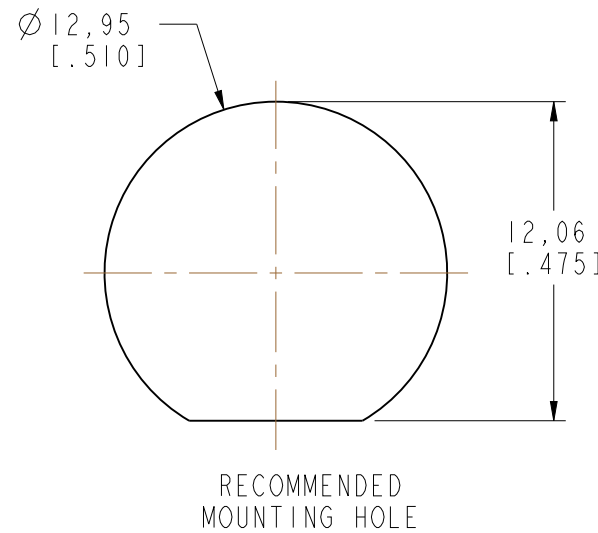

CUSTOMER OUTLINE DRAWING

ALL OTHER SHEETS ARE FOR INTERNAL USE ONLY

UNLESS OTHERWISE SPECIFIED, DIMENSIONS ARE IN METRIC AND TOLERANCES ARE:
 <0.5mm ± 0.05mm 0.5 - 6mm ± 0.1mm 6 - 30mm ± 0.2mm 30 - 120mm ± 0.3mm ANGLES ± 1°

NOTICE - These drawings, specifications, or other data (1) are, and remain the property of Amphenol corp. (2) must be returned upon request; and (3) are confidential and not to be disclosed to any person other than those to whom they are given by Amphenol Corp. the furnishing of these drawings, specifications, or other data by Amphenol Corp., or to any other person to anyone for any purpose is not to be regarded by implication or otherwise in any manner licensing, granting rights to permitting such holder or any other person to manufacture, use or sell any product, process or design, patented or otherwise, that may in any way be related to or disclosed by said drawings, specifications, or other data.

MATERIAL	DRAWN M.ZHANG	DATE 09-Nov-16	TITLE BNC JACK, SEALED BULKHEAD, (RD316 CABLE)	Amphenol RF www.amphenolrf.com
REFERENCE AND CONFIGURATION LEVEL: In Work	ENGINEER S.DUAN	DATE 09-Nov-16	SCALE: 3.5:1.0 SHEET 2 OF 2	DRAWING NO. B6421HI-001-NT3G-50
FINISH	APPROVED S.HSIEH	DATE 09-Nov-16	DWG SIZE B	ITEM NO. 016421ADA36NA5F
	CAD FILE		REV B	PART NO. 112517-10