

dargestellt / drawing shows: 144741
 Oberfläche / plating: vergoldet / Au-plating
 Montage immer mit Sicherungsscheibe, z. B. von Schnorr
 assembly always with circlip, for example from schnorr
 1) unter 3,2 mm zusätzliche Unterlegscheibe verwenden
 up to 3.2 mm use washer additional.
 2) maximales Anzugsmoment: 200 Ncm
 max. torque: 200 Ncm

Layout
144768
144769

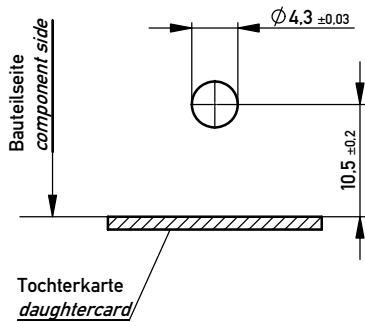

Layout
144741
144742

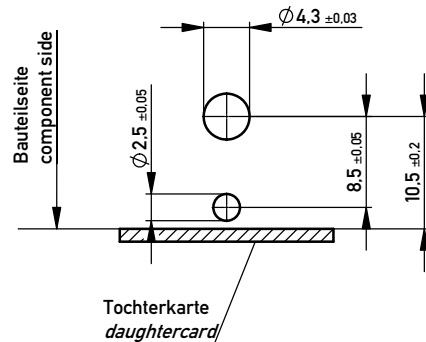

144769	12	24	3	6,5	4,5	-	-	6-8	Direktmontage auf Leiterplatte to fit on backplane without housing 134734
144742	13,8	22,2	1,2	6,5	6,3	1,8	Ø6	6-8	Verwendung mit Grundkörper 134734 2) use only with housing 134734 2)
144768	9,7	24	3	7,2	1,5	-	-	2,5-6 1)	Direktmontage auf Leiterplatte to fit on backplane without housing 134734
144741	11,5	22,2	1,2	7,2	3,3	1,8	Ø6	2,5-6 1)	Verwendung mit Grundkörper 134734 2) use only with housing 134734 2)
Ident-Nr. Part-No.	A	B	C	D	E	F	G	Leiterplattenstärke thickness of backplane	Bemerkungen / remarks

Copyright by ERNI GmbH.
 Proprietary notice pursuant to ISO 9006 to be observed.

All rights reserved.
 Only for Information.
 To ensure that this is the latest
 version of this drawing, please
 contact one of the ERNI companies
 before using.

Subject to modification without
 prior notice.
 Drawing will not be updated.

ERNI www.ERNI.com

Tolerances



All Dimensions
in mm

Scale 5:1

Designation

Führungsstift, vergoldet
 Guiding System ERmet

154553

I
A3

g 18.06.2013
 Index Date

Class ERMEZT