

INSTRUCTION MANUAL

FEATURES

- SOCKET ACCEPTS EITHER PCM1737 OR PCM1739
- ON-BOARD LOW-PASS FILTERS FOR LEFT AND RIGHT CHANNELS
- EASY CONFIGURATION USING ON-BOARD SWITCHES AND JUMPERS
- 96kHz DIGITAL AUDIO RECEIVER ACCEPTS S/PDIF AND OPTICAL INPUTS
- DEMONSTRATION SOFTWARE FOR PROGRAMMING AND READING THE PCM1737's INTERNAL REGISTERS (requires a PC running Microsoft Windows® 3.1, 95, or 98)
- CENTRONICS CONNECTOR FOR INTERFACING TO A PC PARALLEL PORT (required for the demonstration software)

- POWER SUPPLY REQUIREMENTS: +5V, +15V, and -15V
- CONNECTOR FOR OPTIONAL EXTERNAL +3.3V POWER SUPPLY

DESCRIPTION

The DEM-DAI1737/1739 is a complete evaluation platform for the PCM1737 and PCM1739 24-bit stereo, audio digital-to-analog converters. All necessary connectors are provided for interfacing to audio test systems and commercial audio equipment.

BLOCK DIAGRAM

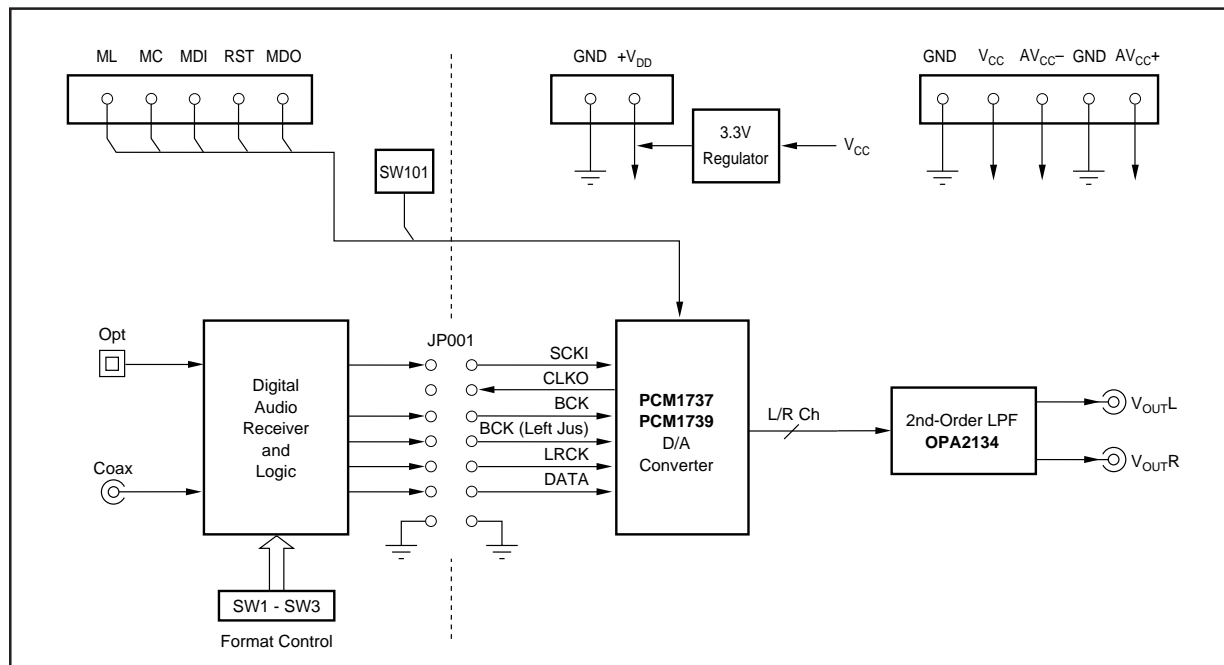

HARDWARE DESCRIPTION

POWER SUPPLIES

The evaluation fixture requires three power supplies for operating the PCM1737 or PCM1739, digital support circuitry, and the low pass filter op amp. These supplies are connected to vertical header CN051.

V_{CC} is the +5V power supply. It is used to power the analog sections of the PCM1737 or PCM1739, as well as the digital audio receiver (U002) and associated logic (U003 and U004).

AV_{CC+} and AV_{CC-} are used to power the Burr-Brown OPA2134 dual op amp (U201), which performs the D/A output low pass filter function. AV_{CC+} may be set from +5V to +18V, while AV_{CC-} may be set from -5V to -18V.

In addition to the three required external power supplies, a +3.3V supply is required for the PCM1737 or PCM1739. The +3.3V supply is typically derived from V_{CC} using an on-board linear regulator, Burr-Brown's REG1117-3.3 (U051). A jumper must be installed at CN053 to connect the regulator output to the PCM1737 or PCM1739.

A connector (CN052) is provided for connection to an optional external +3.3V power supply. When using CN052, the jumper at CN053 must be removed in order to disable the regulator output.

ANALOG OUTPUTS

The Left and Right audio outputs are available at RCA jacks CN201 and CN202 respectively. The outputs are taken from the low pass filter, which has a gain of 2. The low-pass filter may be configured for one of two cut-off frequencies: 54kHz or 108kHz.

For $f_{-3dB} = 54\text{kHz}$, jumpers JP201 through JP206 must all be installed.

For $f_{-3dB} = 108\text{kHz}$, jumpers JP201 through JP206 must all be removed.

ZERO FLAG OUTPUTS

The zero flags for the Left and Right channels are brought out on connector CN101. ZFGL is the zero flag for the Left channel, while ZFGR is the zero flag for the right channel. The zero flags are normally Low, but will switch to a High state when 1024 consecutive sample periods (or LRCK periods) have passed with all 0's data on the DIN (or DATA) input. These flags may be used to control external mute circuitry, or as status indicators for a microcontroller, audio DSP/decoder, or other digitally controlled functions.

DIGITAL AUDIO INTERFACE

A digital audio receiver (U002) is provided for easy connection to S/PDIF and optical signal sources, including audio test systems (Audio Precision, Rhode & Schwarz) and commercial audio equipment (CD and DVD players). The receiver can operate up to a 96kHz word rate with 24-bit data. Switches SW001 through SW003 are used to set the receiver output data format, as shown in Table I. Table II shows the jumper configuration for JP001 when using the digital audio receiver.

SW001	SW002	SW003	RECEIVER OUTPUT DATA FORMAT
L	L	L	16- to 24-Bit, Left-Justified
L	H	L	16- to 24-Bit, I ² S
H	L	H	16-Bit, Right-Justified (or Standard)
L	H	H	18-Bit, Right-Justified (or Standard)

TABLE I. Digital Audio Receiver Configuration.

JP001 JUMPER	16-BIT RIGHT-JUSTIFIED FORMAT	18-BIT RIGHT-JUSTIFIED FORMAT	16- TO 24-BIT I ² S FORMAT	16- TO 24-BIT LEFT-JUSTIFIED FORMAT
SCKI	O	O	O	O
BCK (Left Jus)	NC	NC	NC	O
BCK	O	O	O	O
LRCK	O	O	O	O
DATA	O	O	O	O
CLKO	X	X	X	X
GND	O	O	O	O

O = Install Jumper; NC = Remove Jumper, X = Don't Care.

TABLE II. JP001 Jumper Configuration for Use with the Digital Audio Receiver.

Switch SW004 is a normally open, momentary contact pushbutton switch used to reset the digital audio receiver when necessary.

In addition to the digital audio receiver, the evaluation fixture may be interfaced to an external audio DSP, decoder, or alternative signal source through connector JP001 using standard ribbon cable connections.

DIP SWITCH CONFIGURATION—PCM1737

DIP switch SW101 is used primarily for configuration of the PCM1739. When using the PCM1737, the switches should be set as follows:

FILT = L

MUTE = L

IBIT = L

1739 = L

RSTB = H

DEM0 = H

DEM1 = H

FORM = H

RSTB may be used to force an external reset of the PCM1737. This is done by setting RSTB = L, followed by setting RSTB = H.

DIP SWITCH CONFIGURATION—PCM1739

When using the PCM1739, the 1739 switch of SW101 must be set to the 'H' position.

SW101 is used to set the configuration of the PCM1739's mode controls. Table III shows the available settings for SW101.

SW101 SWITCH(s)	SETTING	FUNCTION
FILT	L	8x Oversampling (used for f_s up to 96kHz)
	H	4x Oversampling (used for $f_s > 96kHz$)
MUTE	L	Mute Disabled, Normal Operation
	H	Mute Enabled, Outputs Forced to Bipolar Zero
IBIT	L	24-Bit Audio Data Word Length
	H	16-Bit Audio Data Word Length
RSTB	L	Reset Mode, Outputs Forced to Bipolar Zero
	H	Normal Operation
DEM0 DEM1		Digital De-Emphasis DEM1 DEM0 Selection L L De-Emphasis Disabled L H 32kHz De-Emphasis Filter H L 44.1kHz De-Emphasis Filter H H 48kHz De-Emphasis Filter
FORM	L	Standard, Right-Justified Data Format
	H	I ² S Data Format

TABLE III. PCM1739 Mode Control Settings.

PC PARALLEL PORT/HOST CONNECTOR

The evaluation fixture includes a Centronics connector, CN102, which is used to connect to a PC parallel (or printer) port, or an alternative host controller. This connector is utilized to access the serial control port of the PCM1737. The serial control port is used to program and read the PCM1737's internal registers.

A standard printer cable is used to connect CN102 of the evaluation fixture to a PC parallel port.

SCHEMATICS

Figures 1 through 4 provide schematics for the DEM-DAI1737/1739.

PCB LAYOUT

Figures 4 through 6 provide PCB plots for the DEM-DAI1737/1739.

The information provided herein is believed to be reliable; however, BURR-BROWN assumes no responsibility for inaccuracies or omissions. BURR-BROWN assumes no responsibility for the use of this information, and all use of such information shall be entirely at the user's own risk. Prices and specifications are subject to change without notice. No patent rights or licenses to any of the circuits described herein are implied or granted to any third party. BURR-BROWN does not authorize or warrant any BURR-BROWN product for use in life support devices and/or systems.

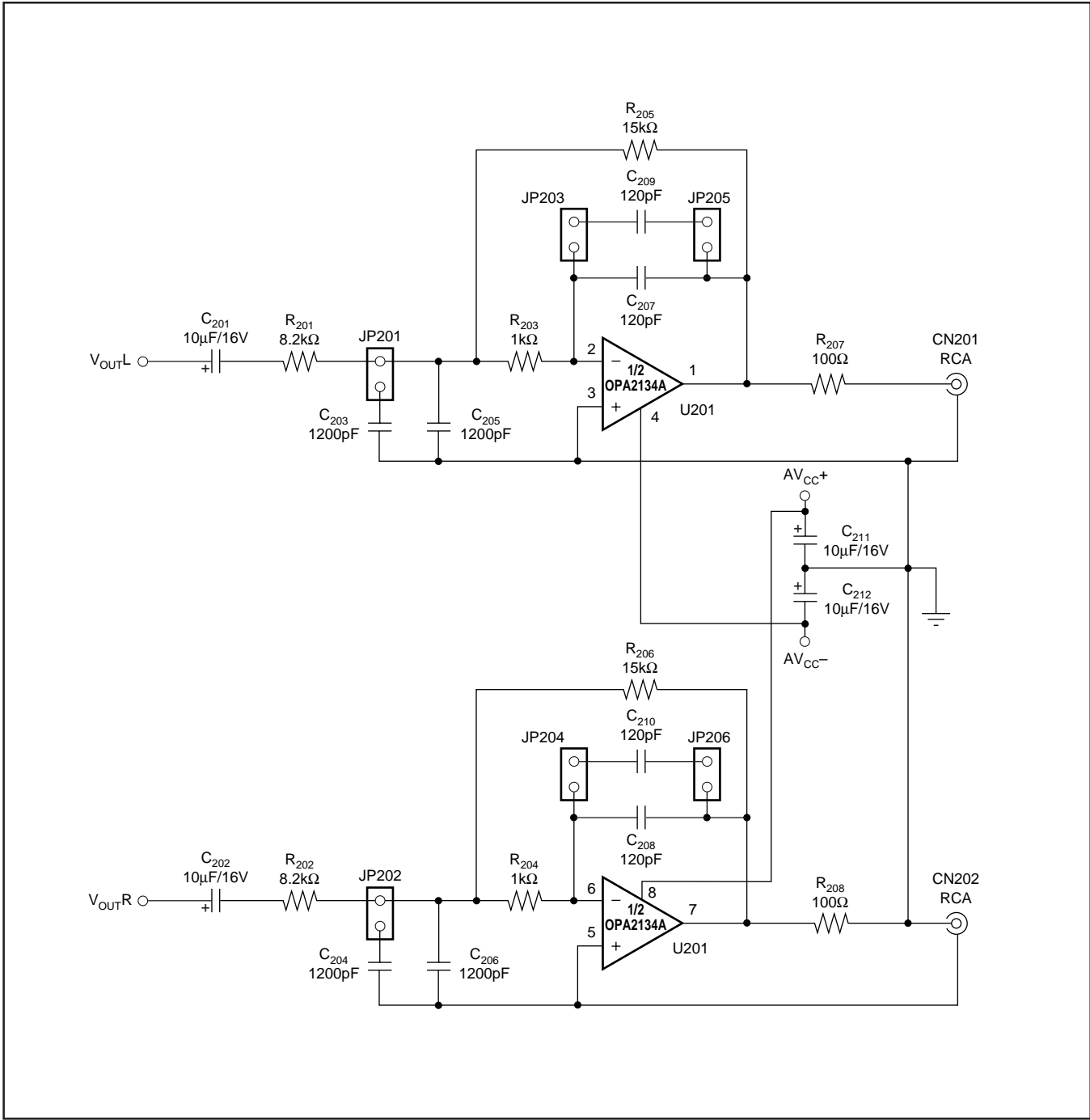

FIGURE 2. DAC Low-Pass Filters.

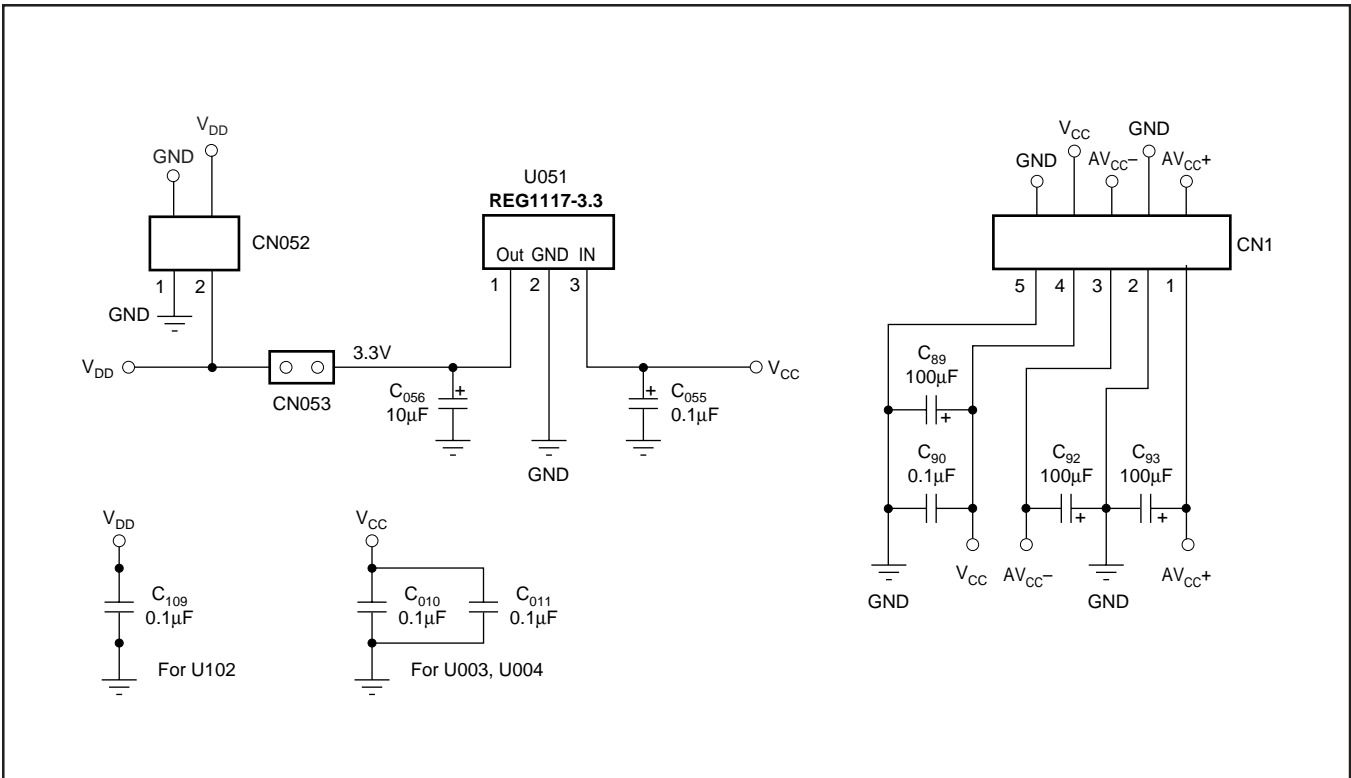

FIGURE 3. Power Supply Connections.

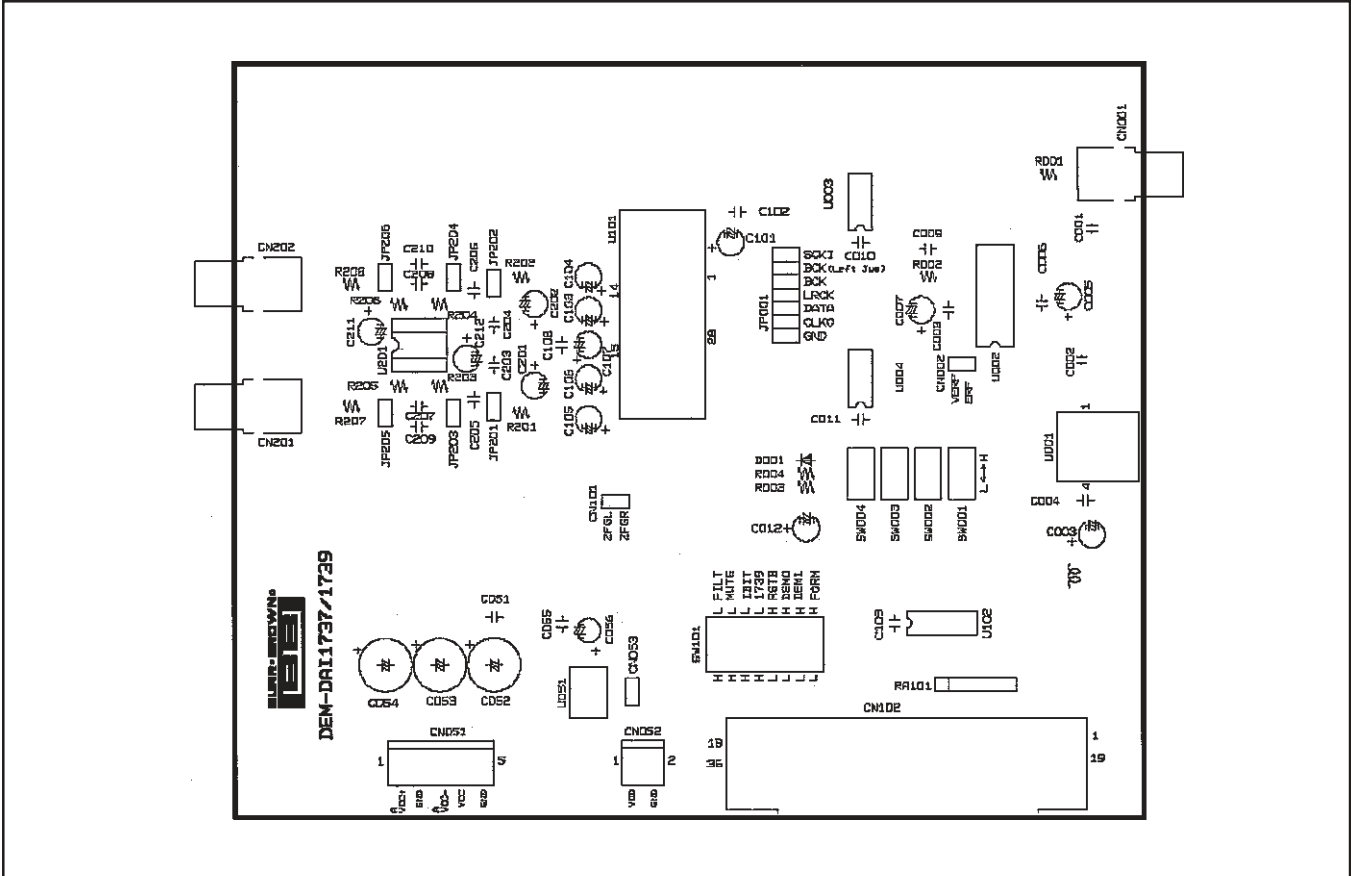

FIGURE 4. Silk Screen (top side).

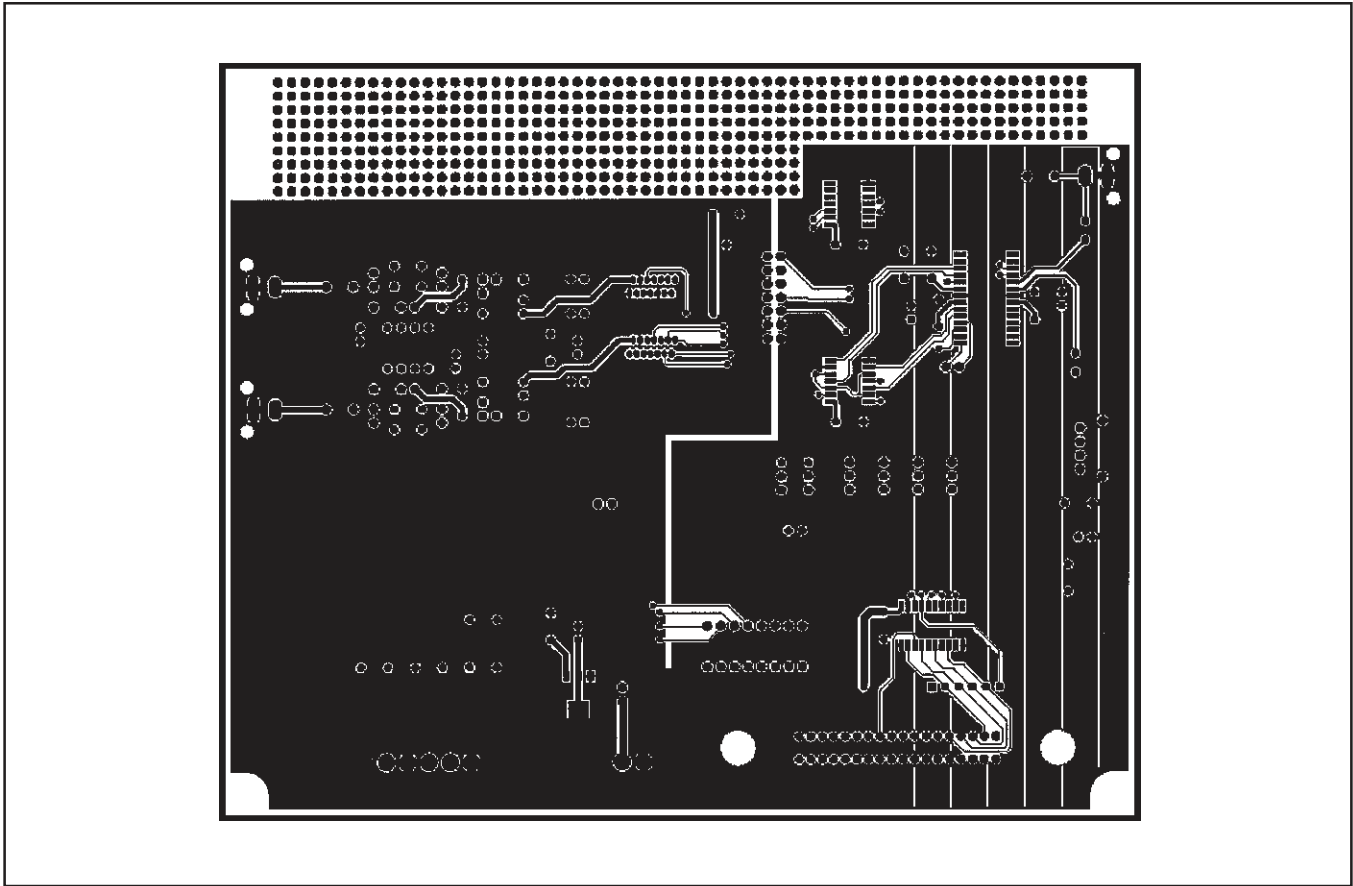

FIGURE 5. Top Side Layer.

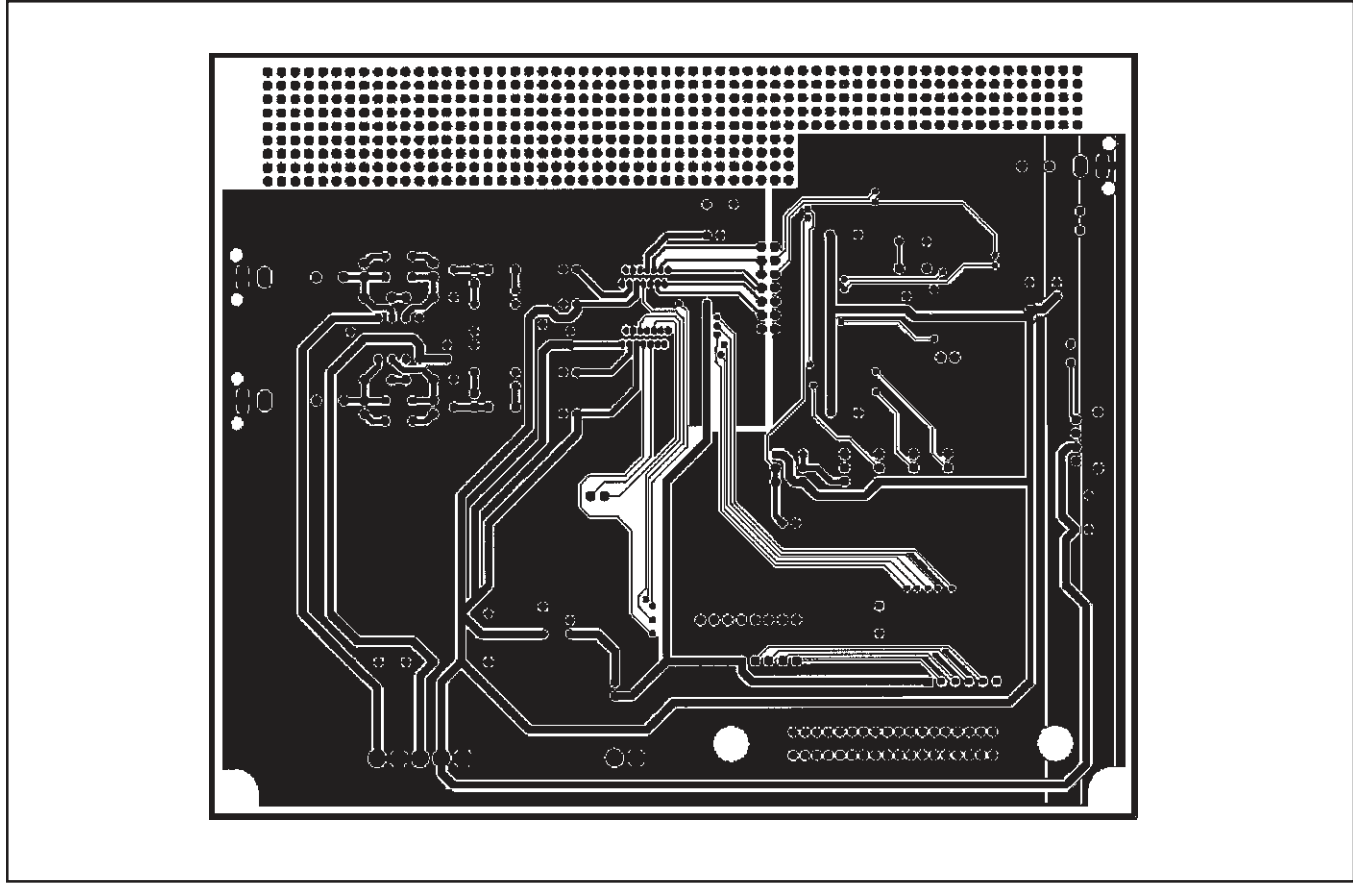

FIGURE 6. Bottom Side Layer.

PCM1737 DEMONSTRATION SOFTWARE

Software is provided with the DEM-DAI1737/1739 to allow programming of the PCM1737's internal registers. The software will operate on computers running Microsoft Windows 3.1, 95, or 98. The demo software requires that the PC printer port be connected to CN102 of the DEM-DAI1737/1739 using a standard printer cable.

INSTALLATION

The demo software is distributed on a 3.5-inch floppy disk. There is a single folder on the disk, named "Dem1737". This folder contains the application and all support files.

To install the software on your computer, first create a new folder on your hard drive with an appropriate name (e.g., Dem1737, Pcm1737, etc). Then open the "Dem1737" folder on the installation floppy and copy all of the files in it to your new folder.

Open the configuration settings file named "Dem1737" with a text editor, such as Notepad or WordPad. When the file is opened, find the following line:

```
PCMIFADR = &h378
```

The &h378 indicates the printer port address that the demo software will use to communicate with the DEM-DAI1737/1739. This address must be set to &h378, &h278, or &h3BC. Most PC's use &H378 as the default printer port address. If your printer port is not located at &h378, edit the address to match your computers port address.

USING THE DEMO SOFTWARE

Double click on the application file named "dem1737". A window will appear on your screen, as shown in Figure 7. There are two menus near the top of the window, named Execute and Window.

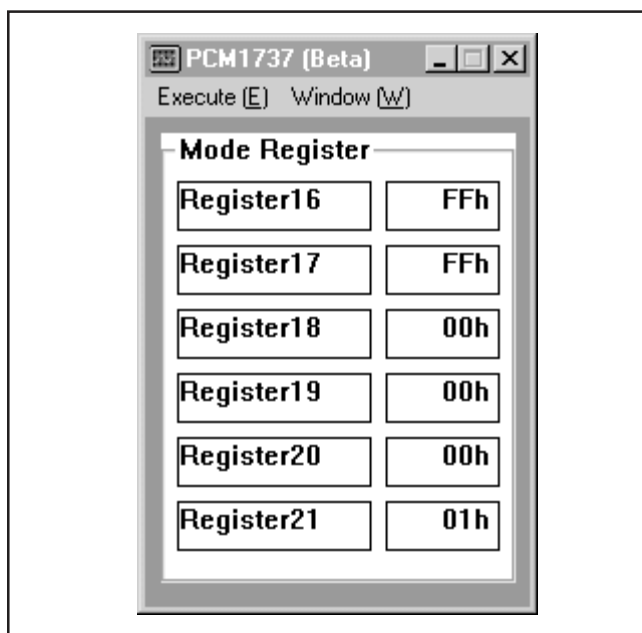

FIGURE 7. Startup Window.

The Execute menu includes three selections: Initialize, Reset, and Exit. Selecting Initialize will instruct the program to write all of the PCM1737's internal registers with the default values. Selecting Reset will instruct the program to re-write the PCM1737's internal registers with the data currently selected in the application windows. Selecting Exit will close the application.

The Window menu includes four selections: Attenuation, Operational Control, Function Control, and Register Read. The following sections provide an explanation of each window.

HOLD and PASS

Each window has a button near the top. It's labeled either HOLD or PASS. The setting is toggled by clicking on this button. When set to HOLD, the user can change the settings in a window but they will not be written to the register(s) until the OK button (which appears at the bottom left corner of the window) is pressed. When set to PASS, changes made within a window are immediately written to the corresponding register(s).

Attenuation Window

The Attenuation window is used to set the digital attenuation registers internal to the PCM1737 and is shown in Figure 8. There is an attenuator for both the Left and Right output channels, and each attenuator has its own independent register to control its level. In the Attenuation window, there is a slider for each attenuator register. Use the slider handle or the arrows at each end of the slider to adjust the attenuation level. The left and right arrow keys on the keyboard can also be used to adjust the level. Just below each slider is a status display showing the current register setting (in decimal) and the corresponding attenuation level in decibels (dB) relative to the input signal level.

The Attenuation window also includes the ATLD, or Attenuation Load Control. When ATLD is set to OFF, the attenuator function is disabled. When ATLD is set to LOAD, changes in slider settings will take effect immediately (if the window is set to PASS), or when the OK button is clicked (if the window is set to HOLD).

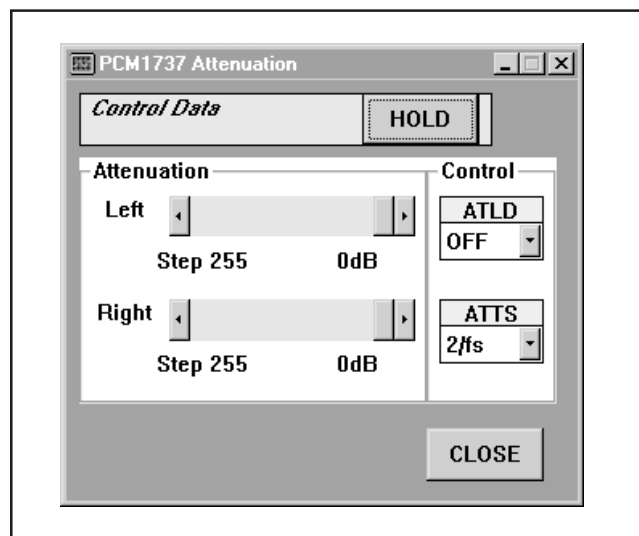

FIGURE 8. Attenuation Window.

The Attenuation window also includes the ATTS, or Attenuation Speed Control. ATTS is used to set the rate at which the attenuator is stepped when a level change is made. The speed is either $2/f_s$ or $4/f_s$, where f_s is the sampling frequency.

Operational Control Window

The Operational Control window is shown in Figure 9. This window is used to set the following functions:

- Soft Mute (Mute Lch, Mute Rch): ON or OFF
- DAC Operation (DAC Lch, DAC Rch): ON or OFF
- Zero Detect Mute (IZD): ON or OFF
- Digital De-Emphasis (DEM): OFF, 32kHz, 44.1kHz, or 48kHz

For more information regarding these functions, refer to the PCM1737 data sheet.

Function Control Window

The Function Control window is shown in Figure 10. This window is used to set the following functions:

- DAC Oversampling Rate (OVER): 64fs or 128fs
- Digital Interpolation Filter Rate (K192): 8x or 4x
- Digital Filter Low Pass Response (FLT): Sharp, Slow 1, or Slow 2
- CLKO Enable (CLKE): ON or OFF
- CLKO Rate (CLKD): f_{SCLK} (Normal) or $f_{SCLK} / 2$ (1/2 XTI)
- Audio Data Format (Format)

For more information regarding these functions, refer to the PCM1737 data sheet.

Register Read Window

The PCM1737 serial control interface includes register read capability. The Register Read window allows the user to read the value of all PCM1737 registers by pressing a single button. The window is shown in Figure 11. The Register Read window provides a means to check for proper communications between the PC printer port and the DEM-DAI1737/1739, by allowing the user to verify register write operations.

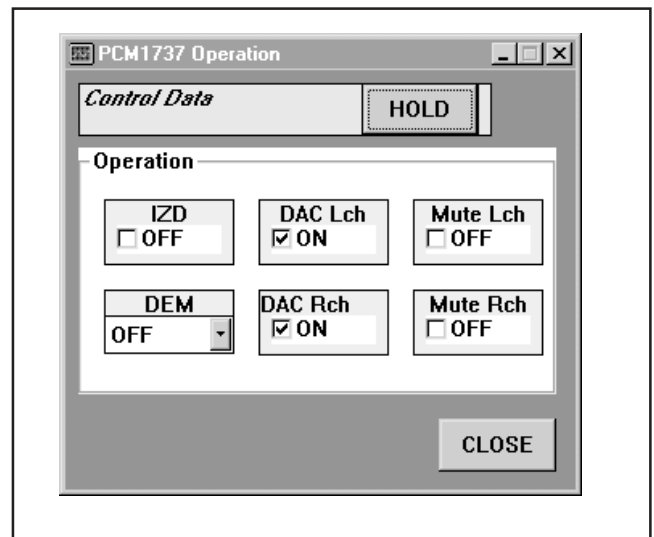

FIGURE 9. Operational Window.

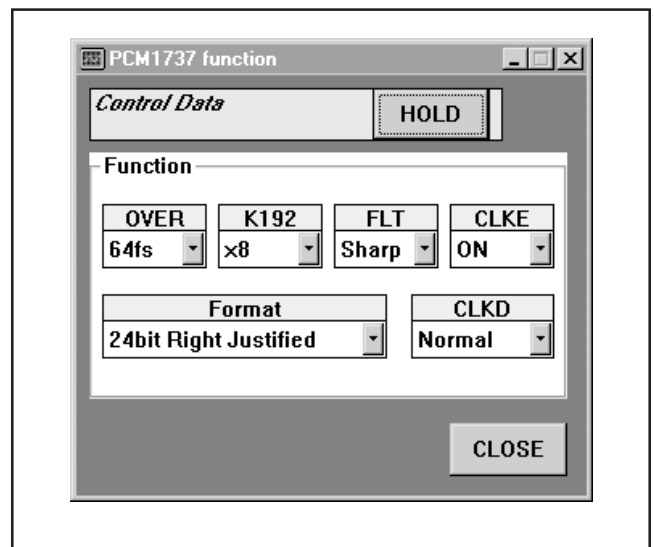

FIGURE 10. Function Control Window.

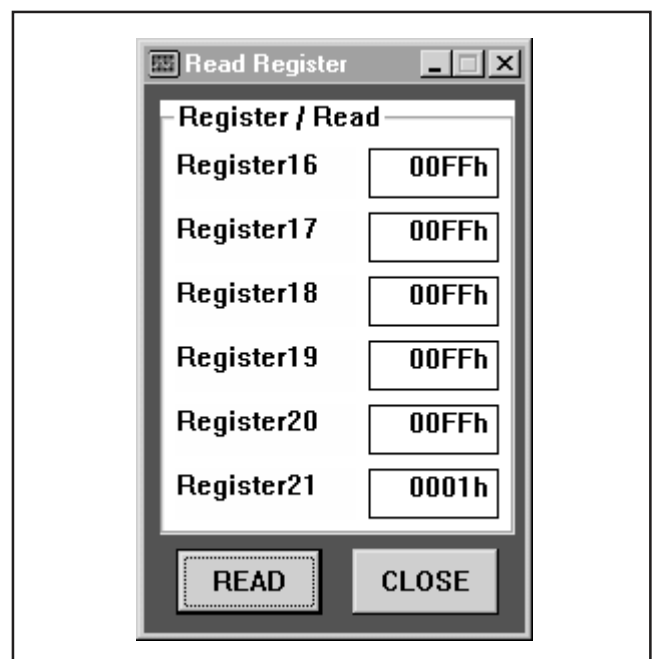

FIGURE 11. Register Read Window.

IMPORTANT NOTICE

Texas Instruments and its subsidiaries (TI) reserve the right to make changes to their products or to discontinue any product or service without notice, and advise customers to obtain the latest version of relevant information to verify, before placing orders, that information being relied on is current and complete. All products are sold subject to the terms and conditions of sale supplied at the time of order acknowledgment, including those pertaining to warranty, patent infringement, and limitation of liability.

TI warrants performance of its semiconductor products to the specifications applicable at the time of sale in accordance with TI's standard warranty. Testing and other quality control techniques are utilized to the extent TI deems necessary to support this warranty. Specific testing of all parameters of each device is not necessarily performed, except those mandated by government requirements.

Customers are responsible for their applications using TI components.

In order to minimize risks associated with the customer's applications, adequate design and operating safeguards must be provided by the customer to minimize inherent or procedural hazards.

TI assumes no liability for applications assistance or customer product design. TI does not warrant or represent that any license, either express or implied, is granted under any patent right, copyright, mask work right, or other intellectual property right of TI covering or relating to any combination, machine, or process in which such semiconductor products or services might be or are used. TI's publication of information regarding any third party's products or services does not constitute TI's approval, warranty or endorsement thereof.