

Low Quiescent Programmable-Delay Supervisory

Description

The DIODES PT7M3808G family of microprocessor supervisory circuits monitor system voltage from 0.4V to 5.0V, asserting an open-drain $\overline{\text{RESET}}$ signal when the SENSE voltage drops below a preset threshold or when the manual reset ($\overline{\text{MR}}$) pin drops to a logic low. The $\overline{\text{RESET}}$ output remains low for the user-adjustable delay time after the SENSE voltage and manual reset ($\overline{\text{MR}}$) return above the respective thresholds.

The PT7M3808G series uses a precision reference to achieve 0.5% threshold accuracy for $V_{IT} \leq 3.3$ V. The reset delay time can be set to 20ms by disconnecting the C_T pin, 300ms by connecting the C_T pin to V_{DD} using a resistor, or can be user-adjusted between 1.25ms and 10s by connecting the C_T pin to an external capacitor. The PT7M3808 has a very low typical quiescent current of 2.8 μ A so it is well-suited to battery-powered applications. It is available in a small SOT23 and an ultra-small 2.0x2.0 TDFN package, and is fully specified over a temperature range of -40°C to +125°C.

Application(s)

- DSP or Microcontroller Applications Capacitor
- Notebook/Desktop Computers
- PDAs/Hand-Held Products Battery-powered Applications
- Portable/Battery-Powered Products
- FPGA/ASIC Applications

Features

- Power-On Reset Generator with Adjustable Delay Time: 1.25ms to 10s.
- Very Low Quiescent Current: 2.8 μ A Typical
- High Threshold Accuracy: 0.5% Typ.
- Fixed Threshold Voltages for Standard Voltage Rails from 0.9V to 5V and Adjustable Voltage Down to 0.4V are available.
- Manual Reset ($\overline{\text{MR}}$) Input.
- Open-Drain $\overline{\text{RESET}}$ Output.
- Temperature Range: -40°C to +125°C
- Totally Lead-Free & Fully RoHS Compliant (Notes 1 & 2)
- Halogen and Antimony Free. "Green" Device (Note 3)
- For automotive applications requiring specific change control (i.e. parts qualified to AEC-Q100/104/101/200, PPAP capable, and manufactured in IATF 16949 certified facilities), please [contact us](#) or your local Diodes representative.
<https://www.diodes.com/quality/product-definitions/>
- Packaging (Pb-free & Green):
 - 6-pins, TDFN 2.0x2.0 (ZC)
 - 6-pins, SOT23 (TA)

Notes:

1. No purposely added lead. Fully EU Directive 2002/95/EC (RoHS), 2011/65/EU (RoHS 2) & 2015/863/EU (RoHS 3) compliant.
2. See <https://www.diodes.com/quality/lead-free/> for more information about Diodes Incorporated's definitions of Halogen- and Antimony-free, "Green" and Lead-free.
3. Halogen- and Antimony-free "Green" products are defined as those which contain <900ppm bromine, <900ppm chlorine (<1500ppm total Br + Cl) and <1000ppm antimony compounds.

Block Diagram

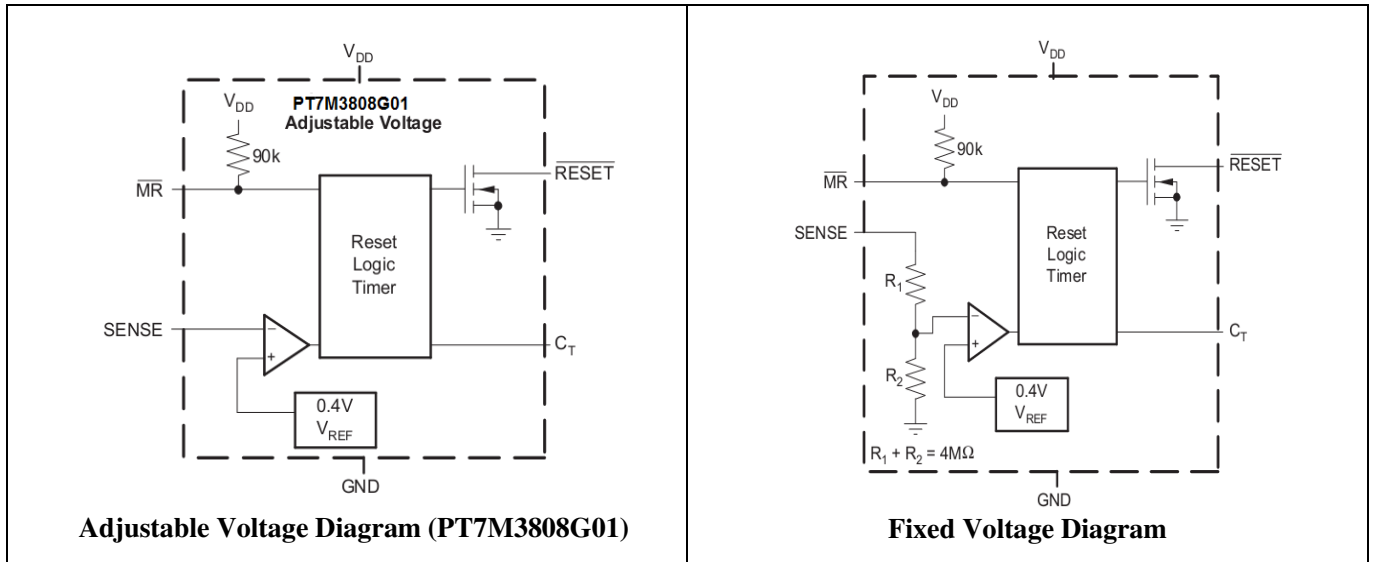

Pin Configuration

TDFN Package

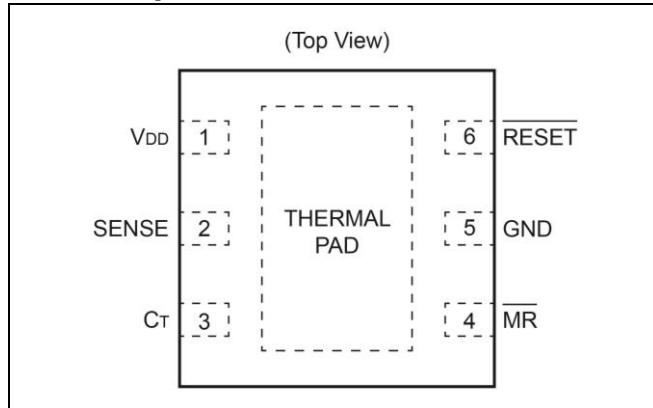

SOT23 Package

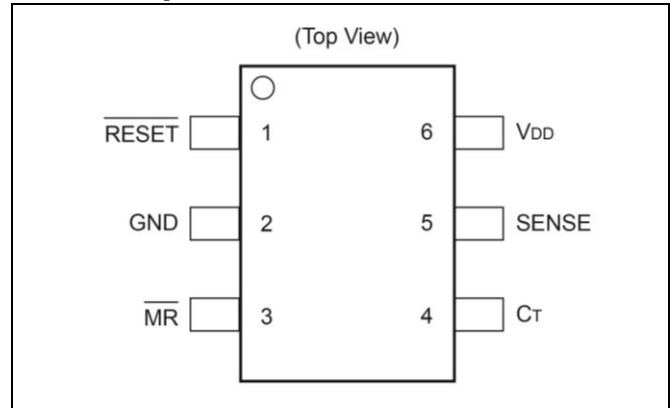

Pin Description

Pin#		Pin Name	Description
SOT23	TDFN		
1	6	$\overline{\text{RESET}}$	An open-drain output that is driven to a low impedance state when $\overline{\text{RESET}}$ is asserted. $\overline{\text{RESET}}$ will remain low (asserted) for the reset period after both SENSE is above V_{IT} and $\overline{\text{MR}}$ is set to a logic high. A pull-up resistor from 10k Ω to 1Mohm should be used on this pin, and allows the reset pin to attain voltages higher than V_{DD} .
2	5	GND	Ground.
3	4	$\overline{\text{MR}}$	Driving the manual reset pin ($\overline{\text{MR}}$) low asserts $\overline{\text{RESET}}$. MR is internally tied to V_{DD} by a 90kohm pull-up resistor.
4	3	C_T	Reset period programming pin. Connection this pin to V_{DD} through a 40k Ω to 200k Ω resistor for 300ms or leaving it open results in fixed delay times 20ms. And connecting this pin with a cap $\geq 100\text{pF}$ to ground a user-programmable delay time.
5	2	SENSE	This pin is connected to the voltage to be monitored. If the voltage at this terminal drops below the threshold voltage V_{IT} , then RESET is asserted.
6	1	V_{DD}	Supply Voltage. Place a 0.1 μF ceramic capacitor close to this pin.
-	PAD	Thermal Pad	Thermal Pad. Connect to ground plane to enhance thermal performance of package.

Maximum Ratings

Storage Temperature	-65°C to +150°C
Operating Junction Temperature, T_J	-40°C to +125°C
Input Voltage Range, V_{DD}	-0.3V to +7.0V
C_T Voltage Range, V_{CT}	-0.3V to $V_{DD}+0.5V$
Other Voltage Range, $V_{\overline{RESET}}$, $V_{\overline{MR}}$, V_{SENSE}	-0.3V to +7.0V
RESET pin Current	5mA
ESD rating, HBM	2kV
ESD rating, CDM	500V

Note:

Stresses greater than those listed under MAXIMUM RATINGS may cause permanent damage to the device. This is a stress rating only and functional operation of the device at these or any other conditions above those indicated in the operational sections of this specification is not implied. Exposure to absolute maximum rating conditions for extended periods may affect reliability.

Recommended Operation Conditions

Symbol	Description	Test Conditions	Min.	Typ.	Max.	Unit
V_{DD}	Supply Voltage		1.7		6.5	V
V_{IH}	Input High Voltage \overline{MR}				V_{DD}	V
	Input High Voltage for Open-drain RESET, SENSE		0		6.5	V
V_{IL}	Input Low Voltage \overline{MR} .				0.3 V_{DD}	V
T_A	Operating Temperature		-40		125	°C

Electrical Characteristics

Unless otherwise specified, $-40^\circ\text{C} \leq T_A \leq 125^\circ\text{C}$, $1.7\text{V} \leq V_{DD} \leq 6.5\text{V}$, $R_{RESET} = 100\text{k}\Omega$, $C_{RESET} = 50\text{Pf}$, Typical values are at $T_A = +25^\circ\text{C}$.

Symbol	Parameter	Test Conditions	Min.	Typ.	Max.	Unit
V_{DD}	Supply voltage		1.7		6.5	V
I_{DD}	Supply current	$V_{DD} = 3.3\text{V}$, \overline{RESET} not asserted, \overline{MR} , \overline{RESET} , C_T open.		2.8	5.0	μA
		$V_{DD} = 6.5\text{V}$, \overline{RESET} not asserted, \overline{MR} , \overline{RESET} , C_T open.		3.0	6.0	μA
V_{OL}	Low level output voltage	$1.3\text{V} \leq V_{DD} < 1.8\text{V}$, $I_{OL} = 0.4\text{mA}$			0.3	V
		$1.8\text{V} \leq V_{DD} \leq 6.5\text{V}$, $I_{OL} = 1.0\text{mA}$			0.4	V
V_{POR}	Power-up reset voltage *	$V_{OL} = 0.2\text{V}$, $I_{RESET} = 15\mu\text{A}$			1.0	V
V_{IT}	Negative-going input threshold	PT7M3808G01	0.375	0.405	0.409	V
		PT7M3808G09	0.81	0.84	0.844	
		PT7M3808G12	1.092	1.12	1.126	
		PT7M3808G125	1.132	1.16	1.166	
		PT7M3808G15	1.373	1.4	1.407	
		PT7M3808G18	1.644	1.67	1.678	
		PT7M3808G19	1.745	1.77	1.779	
		PT7M3808G25	2.308	2.33	2.342	
		PT7M3808G30	2.770	2.79	2.804	
		PT7M3808G33	3.055	3.07	3.085	

Symbol	Parameter	Test Conditions	Min.	Typ.	Max.	Unit	
		PT7M3808G50	4.604	4.65	4.697		
V_{HYS}	Hysteresis on V_{IT} pin	PT7M3808G01		1.5	3.0	% V_{IT}	
		Fixed versions		1	2.5		
$\overline{R_{MR}}$	\overline{MR} Internal pull-up resistance		70	90		k Ω	
I_{SENSE}	Input current at SENSE pin	PT7M3808G01	$V_{SENSE}=V_{IT}$	-25		25	nA
		Fixed versions	$V_{SENSE}=6.5V$		1.8		μA
I_{OH}	\overline{RESET} Leakage Current	$V_{RESET}=6.5V$, \overline{RESET} not asserted				300	nA
C_{IN}	Input capacitance, any pin	C_T pin	$V_{IN}=0V$ to V_{DD}		5		pF
		Other pins	$V_{IN}=0V$ to $6.5V$		5		
V_{IL}	\overline{MR} logic low input		0		$0.3V_{DD}$	V	
V_{IH}	\overline{MR} logic High input		$0.7V_{DD}$		V_{DD}	V	
t_w	Input pulse width to \overline{RESET}	SENSE	$V_{IH}=1.05V_{IT}$, $V_{IL}=0.95V_{IT}$		20		μs
		\overline{MR}	$V_{IH}=0.7V_{DD}$, $V_{IL}=0.3V_{DD}$		0.001		μs
t_D	\overline{RESET} delay time	$C_T=open$		12	20	28	ms
		$C_T=V_{DD}$		180	300	420	ms
		$C_T=100pF$		0.75	1.25	1.75	ms
		$C_T=180nF$		0.7	1.2	1.7	s
t_{pHL}	Propagation delay	\overline{MR} to \overline{RESET}	$V_{IH}=0.7V_{DD}$, $V_{IL}=0.3V_{DD}$		150		ns
	High to low level \overline{RESET} delay	SENSE to \overline{RESET}	$V_{IH}=1.05V_{IT}$, $V_{IL}=0.95V_{IT}$		20		us

Note: The lowest supply voltage (V_{DD}) at which \overline{RESET} becomes active. $Trise(V_{DD}) \geq 15\mu s/V$.

Timing Diagram

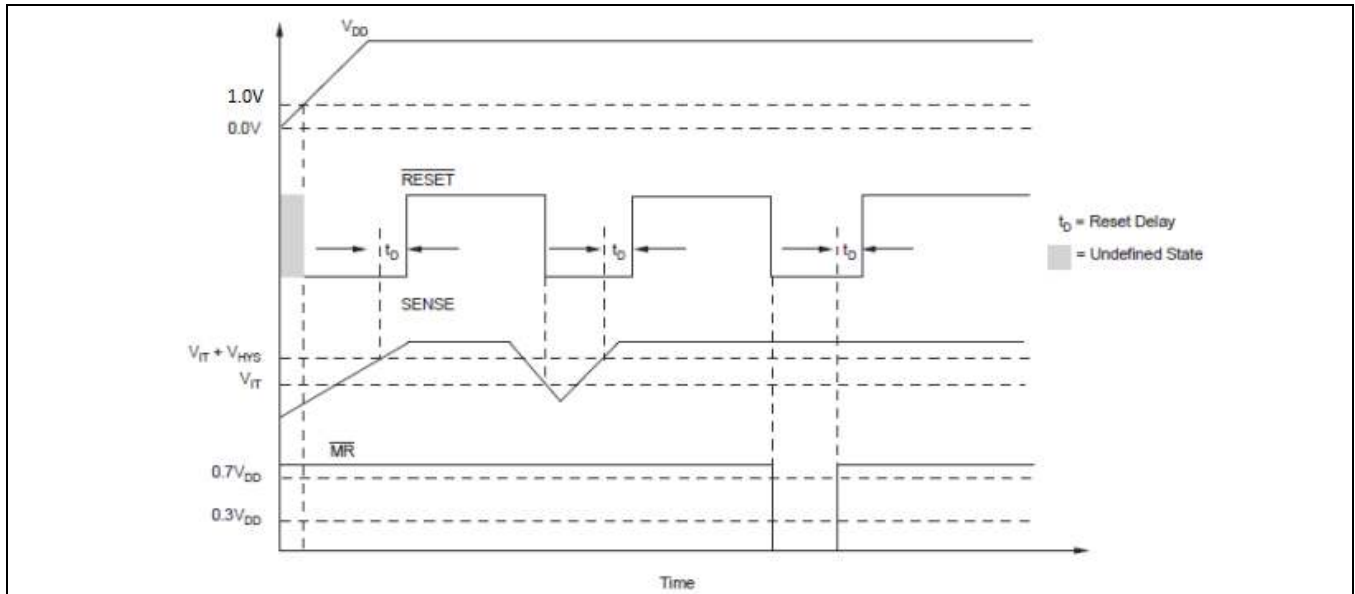

Truth Table

\overline{MR}	$\overline{SENSE} > V_{IT}$	\overline{RESET}
L	0	L
L	1	L
H	0	L
H	1	H

Typical Application Circuit

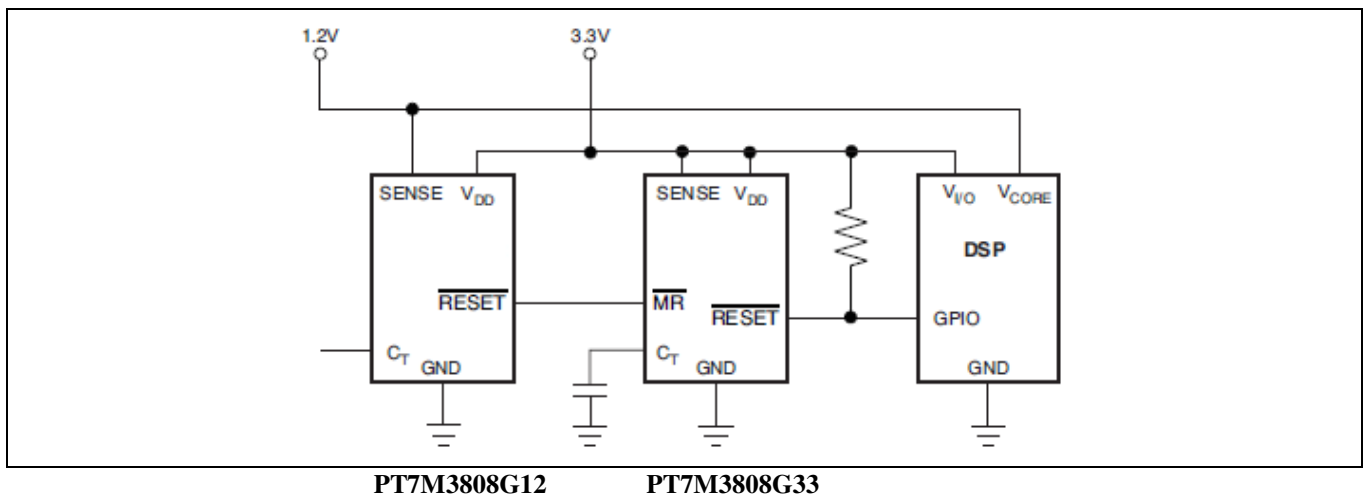

Functional Description

The PT7M3808 microprocessor supervisory product family is designed to assert a $\overline{\text{RESET}}$ signal when either the SENSE pin voltage drops below V_{IT} or the manual reset ($\overline{\text{MR}}$) is driven low. The $\overline{\text{RESET}}$ output remains asserted for a user-adjustable time after both the manual reset ($\overline{\text{MR}}$) and SENSE voltages return above the respective thresholds. A broad range of the voltage threshold and reset delay time adjustments are available, allowing these devices to be used in a wide array of applications. Reset threshold voltages can be factory-set from 0.82V to 3.3V or from 4.4V to 5.0V, while the PT7M3808G01 can be set to any voltage above 0.405V using an external resistor divider. Two preset delay times are also user-selectable: connecting the C_T pin to V_{DD} results in a 300ms reset delay, while leaving the C_T pin open yields a 20ms reset delay. In addition, connecting a capacitor between C_T and GND allows the designer to select any reset delay period from 1.25ms to 10s.

RESET Output

The open-drain $\overline{\text{RESET}}$ output is typically connected to the $\overline{\text{RESET}}$ input of a microprocessor. A pull-up resistor must be used to hold this line high when $\overline{\text{RESET}}$ is not asserted. The $\overline{\text{RESET}}$ output is undefined for voltage below 1.0V, but this is normally not a problem since most microprocessors do not function below this voltage. $\overline{\text{RESET}}$ remains high (unasserted) as long as SENSE is above its threshold (V_{IT}) and the manual reset ($\overline{\text{MR}}$) is logic high. If either SENSE falls below V_{IT} or $\overline{\text{MR}}$ is driven low, $\overline{\text{RESET}}$ is asserted, driving the $\overline{\text{RESET}}$ pin to low impedance.

Once $\overline{\text{MR}}$ is again logic high and SENSE is above $V_{IT} + V_{HYS}$ (the threshold hysteresis), a delay circuit is enabled which holds $\overline{\text{RESET}}$ low for a specified reset delay period. Once the reset delay has expired, the $\overline{\text{RESET}}$ pin goes to a high impedance state. The pull-up resistor from the open-drain $\overline{\text{RESET}}$ to the supply line can be used to allow the reset signal for the microprocessor to have a voltage higher than V_{DD} (up to 6.5V). The pull-up resistor should be no smaller than 10k Ω as a result of the finite impedance of the $\overline{\text{RESET}}$ line.

SENSE Input

The SENSE input provides a pin at which any system voltage can be monitored. If the voltage on this pin drops below V_{IT} , then $\overline{\text{RESET}}$ is asserted. The comparator has a built-in hysteresis to ensure smooth $\overline{\text{RESET}}$ assertions and de-assertions. It is good analog design practice to put a 1nF to 10nF bypass capacitor on the SENSE input to reduce sensitivity to transients and layout parasitic.

The PT7M3808G01 can be used to monitor any voltage rail down to 0.405V by resistor divider.

Manual Reset ($\overline{\text{MR}}$) Input

The manual reset ($\overline{\text{MR}}$) input allows a processor or other logic circuits to initiate a reset. A logic low ($0.3V_{DD}$) on $\overline{\text{MR}}$ will cause $\overline{\text{RESET}}$ to assert. After $\overline{\text{MR}}$ returns to a logic high and SENSE is above its reset threshold, $\overline{\text{RESET}}$ is de-asserted after the user defined reset delay expires. Note that $\overline{\text{MR}}$ is internally tied to V_{DD} using a 90k Ω resistor so this pin can be left unconnected if $\overline{\text{MR}}$ will not be used. Do not apply voltage level over V_{DD} .

Selecting the RESET Delay Time

The PT7M3808 has three options for setting the $\overline{\text{RESET}}$ delay time.

1. A fixed 300ms typical delay time by tying C_T to V_{DD} through a resistor from 40k Ω to 200k Ω . As below Figure (a) shown.
2. A fixed 20ms delay time by leaving the C_T pin open. As below Figure (b) shown.
3. A ground referenced capacitor connected to C_T for a user-defined program time between 1.25ms and 10s. The capacitor C_T should be $\geq 100\text{pF}$ nominal value in order for the PT7M3808xxx to recognize that the capacitor is present. The capacitor value for a given delay time can be calculated using the following equation: $C_T(\text{nF}) = [t_D(\text{s}) - 0.5 \times 10^{-3}(\text{s})] \times 175$. As below Figure (c) shown.

The reset delay time is determined by the time it takes an on-chip precision 220nA current source to charge the external capacitor to 1.23V. When a $\overline{\text{RESET}}$ is asserted the capacitor is discharged. When the $\overline{\text{RESET}}$ conditions are cleared, the internal current source is enabled and begins to charge the external capacitor. When the voltage on this capacitor reaches 1.23V, $\overline{\text{RESET}}$ is de-asserted. Note that a low leakage type capacitor such as a ceramic should be used and the stray capacitance around this pin may cause errors in the reset delay time.

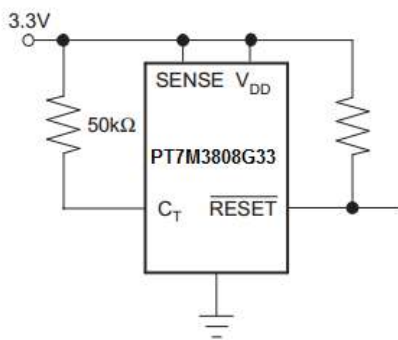

300ms Delay

(a)

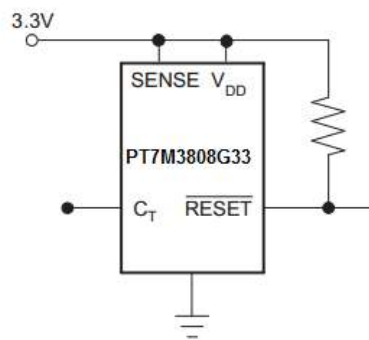

20ms Delay

(b)

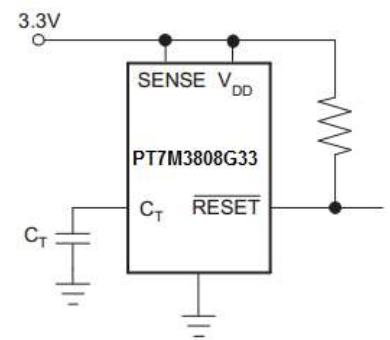

$$\text{Delay (s)} = \frac{C_T \text{ (nF)}}{175} + 0.5 \times 10^{-3} \text{ (s)}$$

(c)

Part Marking

(1) SOT23-6 (TA)

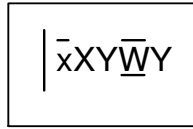

x̄X : Identification code
 1st Y : Year
 W : Date Code (Workweek)
 2nd Y : Die Rev
 Vertical line in front of top mark means Pin1
 Bar about W means Cu wire

Part Number	Package Code	Package	Identification Code	Quantity
PT7M3808G01TAE	TA	SOT23-6	tG	3000
PT7M3808G09TAE	TA	SOT23-6	uU	3000
PT7M3808G12TAE	TA	SOT23-6	uV	3000
PT7M3808G125TAE	TA	SOT23-6	uW	3000
PT7M3808G15TAE	TA	SOT23-6	uX	3000
PT7M3808G18TAE	TA	SOT23-6	uY	3000
PT7M3808G19TAE	TA	SOT23-6	uZ	3000
PT7M3808G25TAE	TA	SOT23-6	wA	3000
PT7M3808G30TAE	TA	SOT23-6	wB	3000
PT7M3808G33TAE	TA	SOT23-6	tH	3000
PT7M3808G50TAE	TA	SOT23-6	wC	3000

(2) TDFN-6 (ZC)

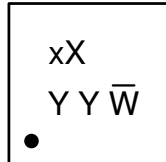

xX : Identification code
 1st Y : Die Rev
 2nd Y : Year
 W : Date Code (Workweek)
 Bar about W means Cu wire

Part Number	Package Code	Package	Identification Code	Quantity
PT7M3808G01ZCE	ZC	TDFN-6	tG	3000
PT7M3808G09ZCE	ZC	TDFN-6	uU	3000
PT7M3808G12ZCE	ZC	TDFN-6	uV	3000
PT7M3808G125ZCE	ZC	TDFN-6	uW	3000
PT7M3808G15ZCE	ZC	TDFN-6	uX	3000
PT7M3808G18ZCE	ZC	TDFN-6	uY	3000
PT7M3808G19ZCE	ZC	TDFN-6	uZ	3000
PT7M3808G25ZCE	ZC	TDFN-6	wA	3000
PT7M3808G30ZCE	ZC	TDFN-6	wB	3000
PT7M3808G33ZCE	ZC	TDFN-6	tH	3000
PT7M3808G50ZCE	ZC	TDFN-6	wC	3000

Packaging Mechanical

6-TDFN (ZC)

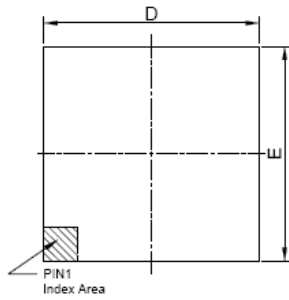

TOP VIEW

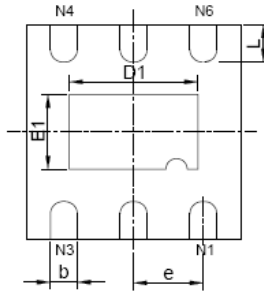

BOTTOM VIEW

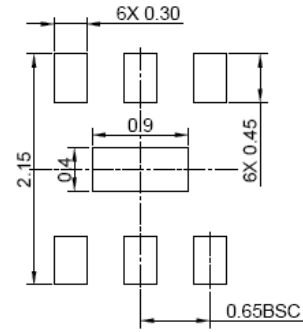

RECOMMENDED LAND PATTERN(unit:mm)

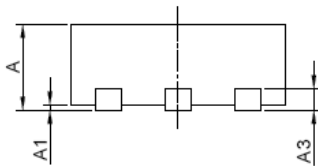

SIDE VIEW

PKG. DIMENSIONS(MM)		
SYMBOL	Min	Max
A	0.70	0.80
A1	0.00	0.05
A3	0.20 REF	
D	2.00 BSC	
E	2.00 BSC	
D1	1.10	1.30
E1	0.60	0.80
b	0.20	0.30
L	0.27	0.43
e	0.65 BSC	

Note:
1. Ref: JEDEC MO-287A



DATE: 12/09/13

DESCRIPTION: 6-Pin, TDFN, 2X2

PACKAGE CODE: ZC (ZC6)

DOCUMENT CONTROL #: PD-2178

REVISION: --

6-SOT23 (TA)

PKG. DIMENSIONS(MM)		
SYMBOL	Min	Max
A	-	1.45
A1	0.00	0.15
A2	0.90	1.30
b	0.30	0.50
c	0.08	0.22
D	2.75	3.05
E	1.45	1.75
E1	2.60	3.00
e	0.95 BSC	
L	0.30	0.60
θ	0°	8°

RECOMMENDED LAND PATTERN

0.95 0.95
1.60 3.40
0.95 0.70

Note:
1. Ref: JEDEC MO-178C/AB
2. PACKAGE OUTLINE DIMENSIONS DO NOT INCLUDE MOLD FLASH AND METAL BURR
3. LAND PATTERN REFERENCE DIODES SOT26(Type-A1) PACKAGE INFORMATION

DIODES INCORPORATED	PERICOM A PRODUCT LINE OF DIODES INCORPORATED ENABLING SERIAL CONNECTIVITY	DATE: 05/17/23
DESCRIPTION: 6-Pin, Small Outline Transistor Plastic Package (SOT23)		
PACKAGE CODE: TA (TA6)		
DOCUMENT CONTROL #: PD-2145	REVISION: B	

For latest package info.

Please check: <http://www.diodes.com/design/support/packaging/pericom-packaging/packaging-mechanicals-and-thermal-characteristics/>.

Ordering Information

Part Numbers	Package Code	Package Description
PT7M3808GxxxZCEX	ZC	6-pin, 2.0x2.0 (TDFN)
PT7M3808GxxxTAEX	TA	6-pin, Small Outline Transistor Plastic Package (SOT23)

Notes:

- No purposely added lead. Fully EU Directive 2002/95/EC (RoHS), 2011/65/EU (RoHS 2) & 2015/863/EU (RoHS 3) compliant.
- See <https://www.diodes.com/quality/lead-free/> for more information about Diodes Incorporated's definitions of Halogen- and Antimony-free, "Green" and Lead-free.
- Halogen- and Antimony-free "Green" products are defined as those which contain <900ppm bromine, <900ppm chlorine (<1500ppm total Br + Cl) and <1000ppm antimony compounds.
- E = Pb-free and Green
- X suffix = Tape/Reel

TDFN Pin 1 Location in Tape and Reel

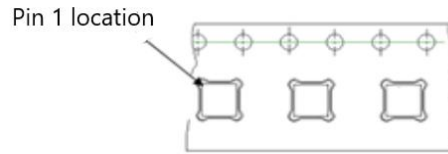

Function Comparison Table

Product	Nominal Supply Voltage	SENSE Threshold Voltage(V_{IT})
PT7M3808G01	adjustable	0.405V
PT7M3808G09	0.9V	0.84V
PT7M3808G12	1.2V	1.12V
PT7M3808G125	1.25V	1.16V
PT7M3808G15	1.5V	1.40V
PT7M3808G18	1.8V	1.67V
PT7M3808G19	1.9V	1.77V
PT7M3808G25	2.5V	2.33V
PT7M3808G30	3.0V	2.79V
PT7M3808G33	3.3V	3.07V
PT7M3808G50	5.0V	4.65V

Mechanical Data

- Moisture Sensitivity: Level 1 per J-STD-020
- Terminals: Finish – Matte Tin Plated Leads, Solderable per MIL-STD-202, Method 208 **(e3)**
- Weight: SOT23-6 0.009 grams (Approximate)
TDFN-6 0.0075g grams (Approximate)

IMPORTANT NOTICE

1. DIODES INCORPORATED (Diodes) AND ITS SUBSIDIARIES MAKE NO WARRANTY OF ANY KIND, EXPRESS OR IMPLIED, WITH REGARDS TO ANY INFORMATION CONTAINED IN THIS DOCUMENT, INCLUDING, BUT NOT LIMITED TO, THE IMPLIED WARRANTIES OF MERCHANTABILITY, FITNESS FOR A PARTICULAR PURPOSE OR NON-INFRINGEMENT OF THIRD PARTY INTELLECTUAL PROPERTY RIGHTS (AND THEIR EQUIVALENTS UNDER THE LAWS OF ANY JURISDICTION).
2. The Information contained herein is for informational purpose only and is provided only to illustrate the operation of Diodes' products described herein and application examples. Diodes does not assume any liability arising out of the application or use of this document or any product described herein. This document is intended for skilled and technically trained engineering customers and users who design with Diodes' products. Diodes' products may be used to facilitate safety-related applications; however, in all instances customers and users are responsible for (a) selecting the appropriate Diodes products for their applications, (b) evaluating the suitability of Diodes' products for their intended applications, (c) ensuring their applications, which incorporate Diodes' products, comply the applicable legal and regulatory requirements as well as safety and functional-safety related standards, and (d) ensuring they design with appropriate safeguards (including testing, validation, quality control techniques, redundancy, malfunction prevention, and appropriate treatment for aging degradation) to minimize the risks associated with their applications.
3. Diodes assumes no liability for any application-related information, support, assistance or feedback that may be provided by Diodes from time to time. Any customer or user of this document or products described herein will assume all risks and liabilities associated with such use, and will hold Diodes and all companies whose products are represented herein or on Diodes' websites, harmless against all damages and liabilities.
4. Products described herein may be covered by one or more United States, international or foreign patents and pending patent applications. Product names and markings noted herein may also be covered by one or more United States, international or foreign trademarks and trademark applications. Diodes does not convey any license under any of its intellectual property rights or the rights of any third parties (including third parties whose products and services may be described in this document or on Diodes' website) under this document.
5. Diodes' products are provided subject to Diodes' Standard Terms and Conditions of Sale (<https://www.diodes.com/about/company/terms-and-conditions/terms-and-conditions-of-sales/>) or other applicable terms. This document does not alter or expand the applicable warranties provided by Diodes. Diodes does not warrant or accept any liability whatsoever in respect of any products purchased through unauthorized sales channel.
6. Diodes' products and technology may not be used for or incorporated into any products or systems whose manufacture, use or sale is prohibited under any applicable laws and regulations. Should customers or users use Diodes' products in contravention of any applicable laws or regulations, or for any unintended or unauthorized application, customers and users will (a) be solely responsible for any damages, losses or penalties arising in connection therewith or as a result thereof, and (b) indemnify and hold Diodes and its representatives and agents harmless against any and all claims, damages, expenses, and attorney fees arising out of, directly or indirectly, any claim relating to any noncompliance with the applicable laws and regulations, as well as any unintended or unauthorized application.
7. While efforts have been made to ensure the information contained in this document is accurate, complete and current, it may contain technical inaccuracies, omissions and typographical errors. Diodes does not warrant that information contained in this document is error-free and Diodes is under no obligation to update or otherwise correct this information. Notwithstanding the foregoing, Diodes reserves the right to make modifications, enhancements, improvements, corrections or other changes without further notice to this document and any product described herein. This document is written in English but may be translated into multiple languages for reference. Only the English version of this document is the final and determinative format released by Diodes.
8. Any unauthorized copying, modification, distribution, transmission, display or other use of this document (or any portion hereof) is prohibited. Diodes assumes no responsibility for any losses incurred by the customers or users or any third parties arising from any such unauthorized use.
9. This Notice may be periodically updated with the most recent version available at <https://www.diodes.com/about/company/terms-and-conditions/important-notice>

The Diodes logo is a registered trademark of Diodes Incorporated in the United States and other countries.
All other trademarks are the property of their respective owners.
© 2023 Diodes Incorporated. All Rights Reserved.

www.diodes.com