

THIS DRAWING IS UNPUBLISHED. RELEASED FOR PUBLICATION
 © COPYRIGHT BY TYCO ELECTRONICS CORPORATION. ALL RIGHTS RESERVED.

DESIGNED FOR USE WITH
 .141 DIA S/R CABLE
 CABLE ENTRY DIAMETER
 MINIMUM

HOUSING	.144
CONTACT	.037

LOC	DIST	REVISIONS			
P	LTR	DESCRIPTION	DATE	DWN	APVD
AJ	00	B	REV PER ECO 07-004710	3-2-2007	DW KW

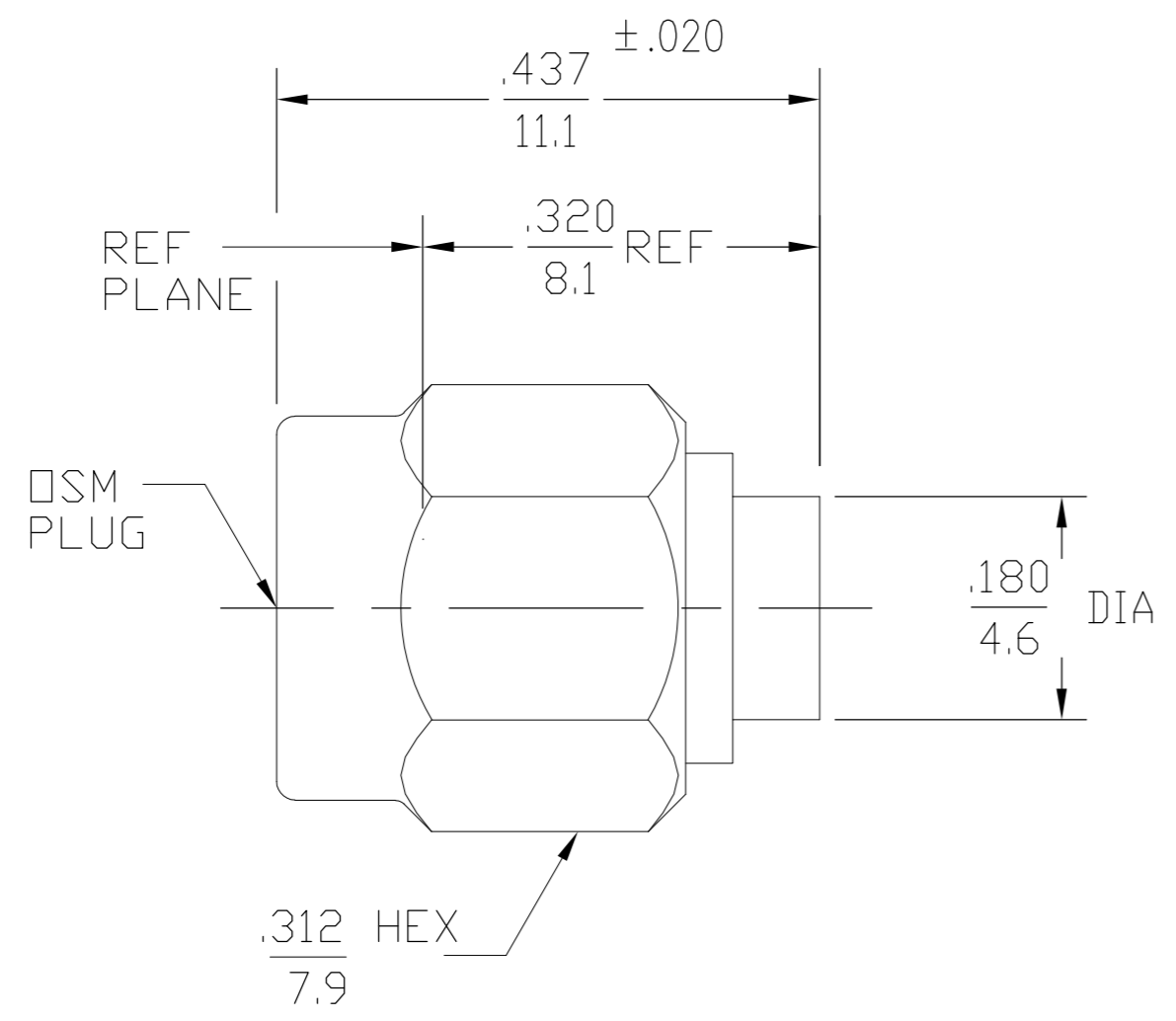

1056227-1
 PART NUMBER

ELECTRICAL	MECHANICAL	ENVIRONMENTAL
Nominal Impedance (Ohms) <u>50</u>	Interface Dimensions MIL-STD-348, Fig. 310.1	TEMPERATURE RATING <u>-65°C TO 125°C</u>
Frequency Range (GHz) DC to <u>27.0</u>	Recommended Mating Torque <u>7-10 Inch Pounds</u>	Vibration MIL-STD-202, Method 204, Condition D
Volt Rating (VRMS MAX) @ Sea Level <u>500</u>	Mating Characteristics: Insertion (MAX Lbs) <u>3.0</u>	Shock MIL-STD-202, Method 213, Condition I
VSWR <u>1.05 + .01 f(GHz)</u>	Withdrawal (MIN Oz) <u>1.0</u>	Thermal Shock MIL-STD-202, Method 107, Condition B, EXCEPT HIGH TEMP SHALL BE 115°C
Insertion Loss (dB MAX) <u>.03 √f(GHz)</u>	Force to Engage and Disengage (In/Lbs MAX) <u>2.0</u>	Moisture Resistance MIL-STD-202, Method 106, Except Vibration
RF Leakage (dB MIN) <u>-90 @ 2-3 GHz</u>	Cable Retention (lbs MIN) <u>60.0</u>	Shall Be Omitted
Corona, 70,000 Ft (VRMS MIN) <u>375</u>	Torque (in-oz) <u>55.0</u>	Corrosion - MIL-STD-202, Method 101, Condition B, 5% salt spray
Dielectric Withstanding Voltage (VRMS MIN) @ Sea Level <u>1,500</u>	Weight (Grams) <u>2.6</u>	
Contact Resistance (Milliohms MAX) Center Contact <u>3.0</u>		
Outer Contact <u>2.0</u>		
RF High Potential @ Sea Level (VRMS MIN @ 5 MHz) <u>1,000</u>		
I.R.(Megohms MIN) <u>5,000</u>		

COMPONENT	MATERIAL	FINISH
HOUSING COUPLING NUT	STAINLESS STEEL PER ASTM-A484 AND ASTM-A582, TYPE 303	GOLD PLATE PER MIL-G-45204
DIELECTRIC	PTFE FLUOROCARBON PER ASTM-D-1457	N/A
CENTER CONTACT	BERYLLIUM COPPER PER ASTM B 196, ALLOY C17300, CONDITION H OR BRASS PER ASTM-B-16	GOLD PLATE PER MIL-G-45204
RETAINING RING	BERYLLIUM COPPER PER ASTM B 194, ALLOY C17200, CONDITION HT	N/A
GASKET	SILICONE RUBBER PER ZZ-R-765	N/A

.XXX = in
 XX.X = mm

THIS DRAWING IS A CONTROLLED DOCUMENT.		DWN SK 4-12-78	Tyco Electronics Corporation Harrisburg, PA 17105-3608
DIMENSIONS: INCHES		CHK KWW 4/13/78	
TOLERANCES UNLESS OTHERWISE SPECIFIED:		APVD RMF 4-19-78	NAME OSM STRAIGHT CABLE PLUG DIRECT SOLDER ATTACHMENT
0 PLC ± -		PRODUCT SPEC -	
1 PLC ± -		APPLICATION SPEC -	SIZE A2
2 PLC ± -		WEIGHT -	CAGE CODE 00779
3 PLC ± .005		SCALE 5:1	DRAWING NO C=1056227
4 PLC ± -		SHEET 1 of 1	RESTRICTED TO -
ANGLES ± 1°		REV B	
MATERIAL -		CUSTOMER DRAWING	