

PART NO.	CARD THICKNESS
RCP-86	1/16 (1.6)
RCP-89	3/32 (2.4)

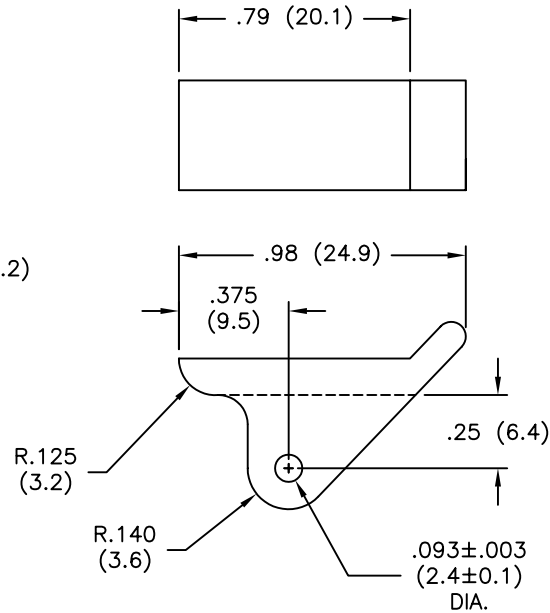
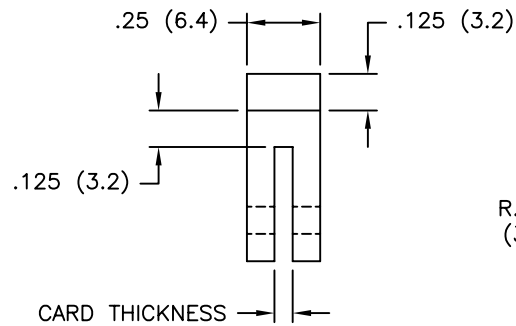
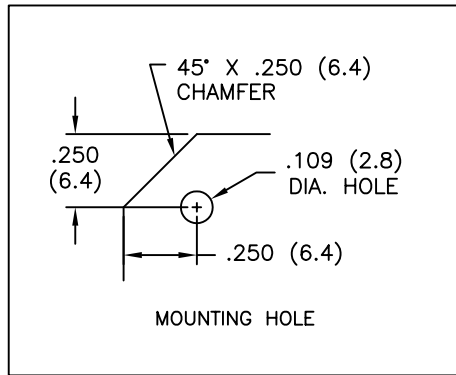

NOTES:

1. MATERIAL: NYLON 6/6 (RMS-48).
2. COLOR: WHITE.
3. INSTALLATION ROLL PIN NO. RRP-250, MATERIAL: PASSIVATED STAINLESS STEEL PER MIL-P-10971. COLOR: SILVER. 3/32 (2.4) DIA. X 1/4 (6.4) LONG, FURNISHED WITH EJECTORS.

TITLE: CARD EJECTORS			DWG IN IN (MM)		FINAL		
D	ADDED MOUNTING HOLE DETAIL, ECN #659	SM 07.02.03	FILE # RCP	DWN: P.B.	APP:	PART # SEE TABLE	PRINT TYPE CA
C	ADDED NOTE 3 (ECN #472)	SM 09.26.02	MAT'L: SEE NOTES	DT: 04-07-94	DT:		
B	CHANGED FILE NUMBER	SM 05.15.01	RE: RICHCO, INC.	RICHCO INC. PO BOX 804238, CHICAGO, 60680 (773) 539-4060			
A	MAT'L COLOR WHITE WAS NATURAL	J.L. 3.17.99	TOLERANCES UNLESS NOTED .XX=±.010 .XXX=±.005 FRAC=±1/64 ANG=±1°				
REV	DESCRIPTION	ENGR DATE					