

PART NAME

TABLET ENCLOSURE

PART No.

TB-32612-B & TB-32612-W

REV. DATE

2-23-13

MATERIAL:
ABS UL94-HB BLACK (SUFFIX -B)
ABS UL94-V0 WHITE (SUFFIX -W)

Ø0.098
[2.5] (8X)
HOLE ACCEPTS M3
SELF-TAPPING SCREW
(NOT SUPPLIED)
TYP. IN BOTTOM

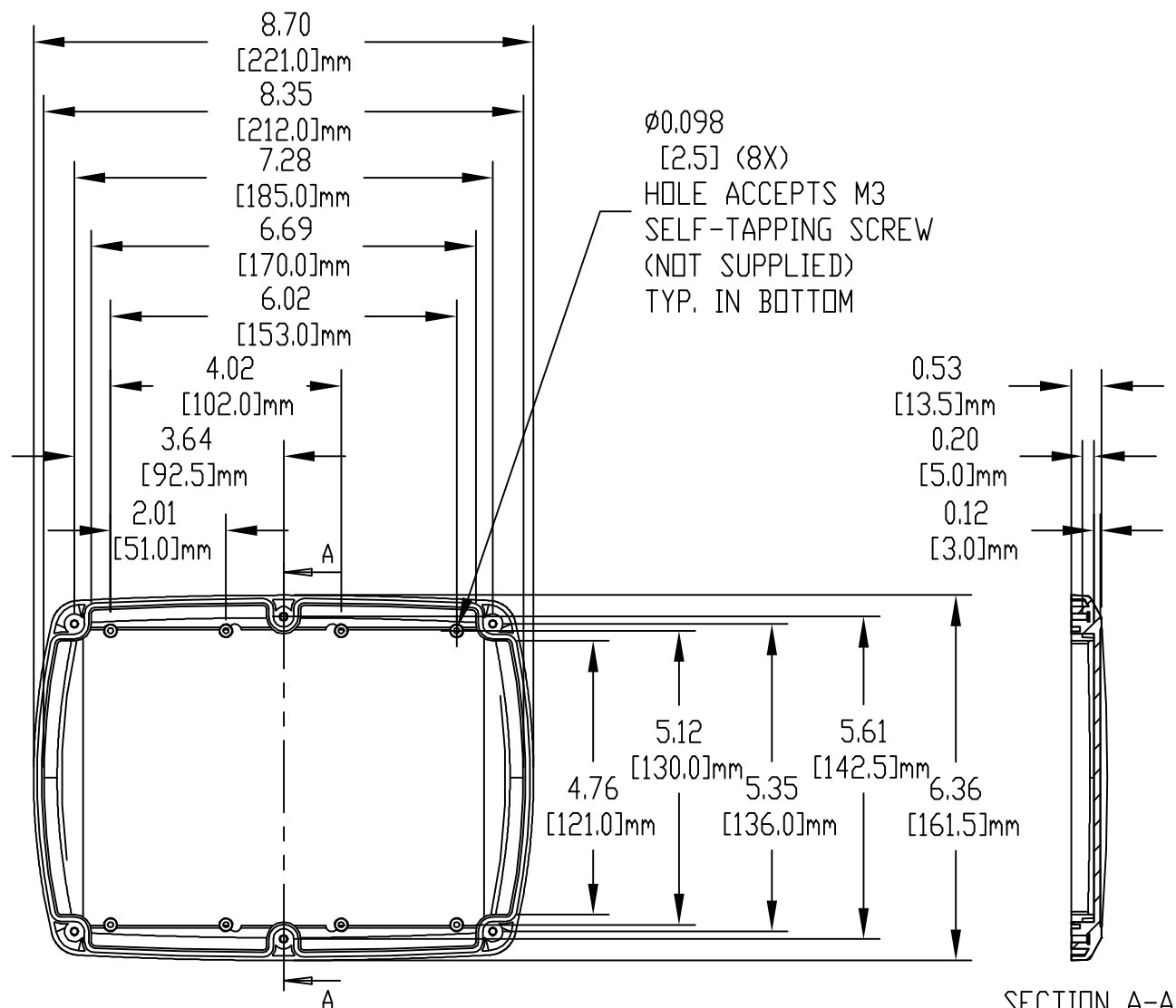

SECTION A-A

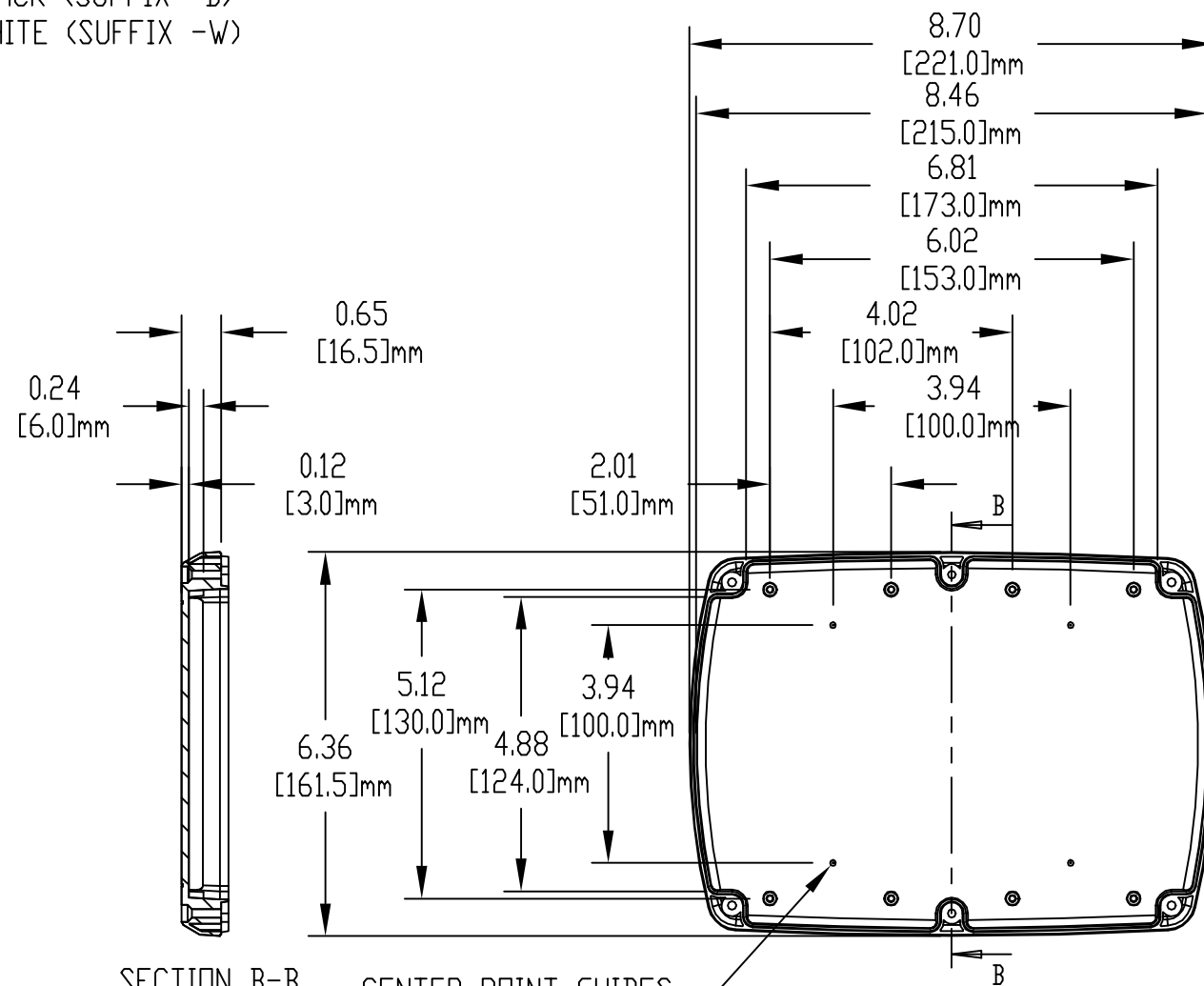

SECTION B-B

CENTER POINT GUIDES
FOR DRILLING WALL
MOUNTING HOLES (4X)

RECESSED AREA ACCEPTS 7.00[177.8]
LCD MODULE OR TOUCH SCREEN

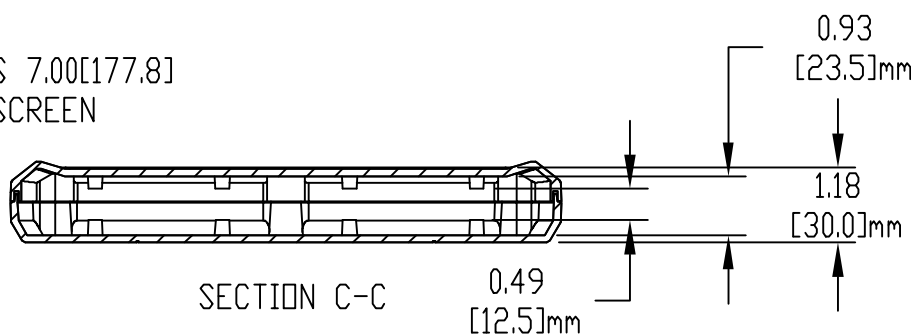
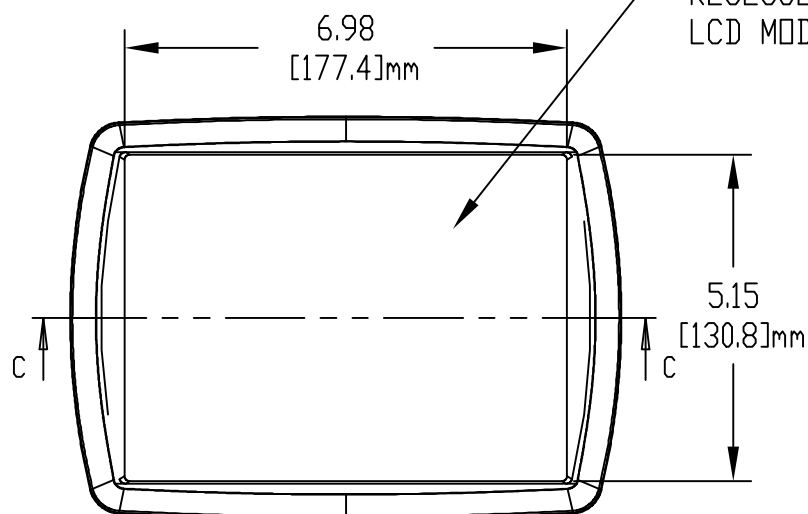

SECTION C-C

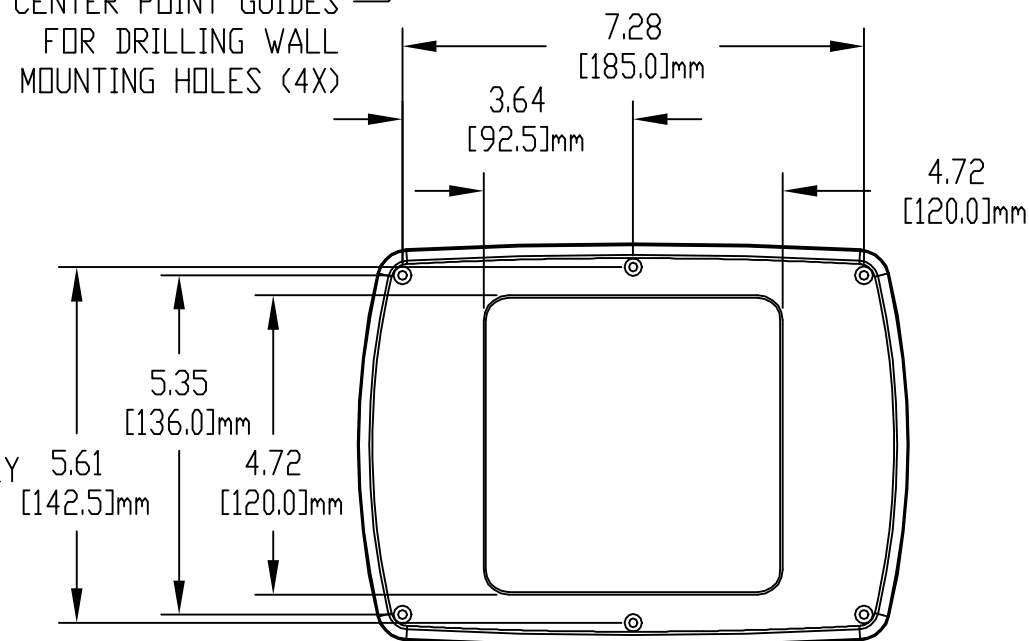

NOTES:

- 1.) SIX (6) M3 x 0.63[16] LG. SELF-TAPPING SCREWS SUPPLIED FOR ASSEMBLY
- 2.) FOUR (4) ADD-ON RUBBER FEET SUPPLIED
- 3.) ALL HOLE DIAMETERS HAVE ±0.005[0.13] TOLERANCE
ALL OTHER DIMENSIONS HAVE ±0.015[0.38] TOLERANCE
- 4.) DIMENSIONS ARE INCH[MILLIMETER] - THIRD ANGLE PROJECTION
- 5.) OPTIONAL SILICONE SPONGE GASKET #TB-32612-GSK AVAILABLE