

Optical Evaluation for LTC6560 Single Channel Transimpedance Amplifier with Output Multiplexing

DESCRIPTION

Demonstration circuit 2803A features the [LTC®6560](#) single channel transimpedance amplifier (TIA) with output multiplexing. The LTC6560, which features 74kΩ transimpedance gain and 30μA linear input current range, is ideal for LIDAR receivers using Avalanche Photodiodes (APD). The LTC6560 operates from 5V single supply and consumes only 90mW. Utilizing the LTC6560's output MUX, multiple LTC6560 devices can be combined to a single output. The LTC6560's fast overload recovery makes it well suited for LIDAR receivers. The LTC6560's single-ended output can swing 2V_{P-P} on a 100Ω load.

The LTC6560 is packaged in a compact 3mm × 3mm 16-pin leadless QFN package with an exposed pad for thermal management and low inductance.

The DC2803A utilizes a single channel 400nm to 1100nm wavelength sensitive APD sensor feeding an LTC6560 for current to voltage conversion and amplification. The APD is DC coupled to the TIA to facilitate fast output multiplexing. The DC2803A is intended to demonstrate time domain measurements into 50Ω systems.

[Design files for this circuit board are available.](#)

All registered trademarks and trademarks are the property of their respective owners.

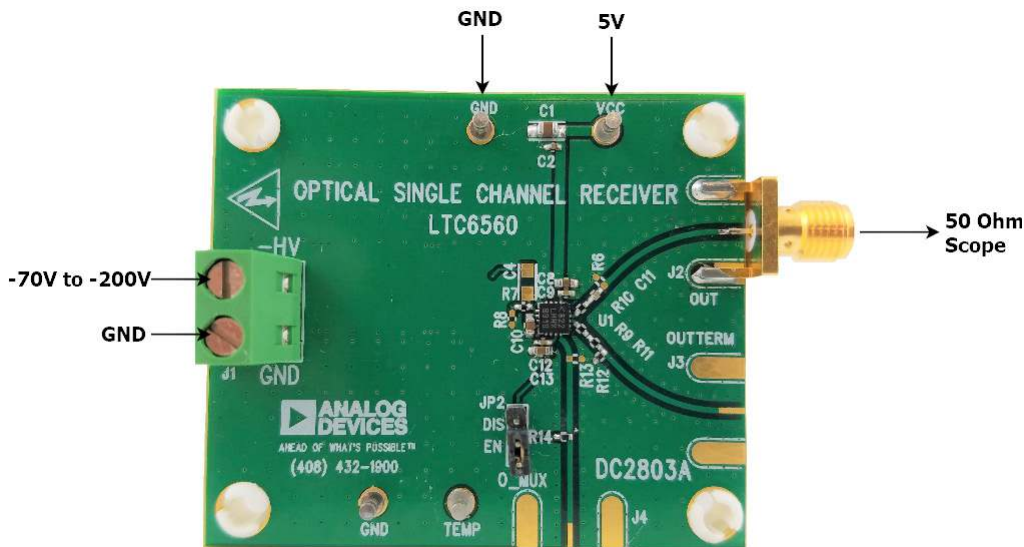

Figure 1. Connection Diagram

QUICK START PROCEDURE

1. Connect J2 to an oscilloscope that is 50- Ω terminated. The output is AC-coupled. J2 is AC-coupled with a 1000pF capacitor.
2. Connect a 5V low noise power supply as shown in Figure 1.
3. Apply -70V to -200V to J1 according to the desired APD gain. The connector and passives are rated up to 300V, but the APD is not rated up to these levels.

WARNING! LETHAL VOLTAGES ARE PRESENT ON THE DC2803A CIRCUIT BOARD. AVOID CONTACT WITH THE HIGH VOLTAGE PATH TO PREVENT PERSONAL INJURY.

4. Apply a 400nm to 1100nm wavelength pulsed laser to the APD which is located on the bottom of the DC2803A shown in Figure 2. The maximum repetition rate of the pulsed laser should be 100kHz. The DC2803A repetition rate is limited by the output AC-coupling capacitor and assumes a pulse width of 5ns.

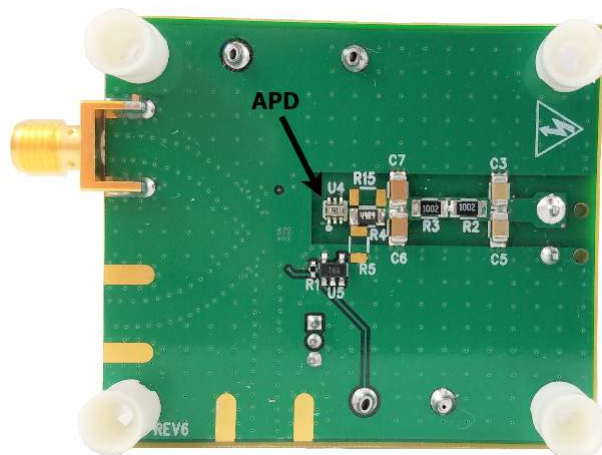
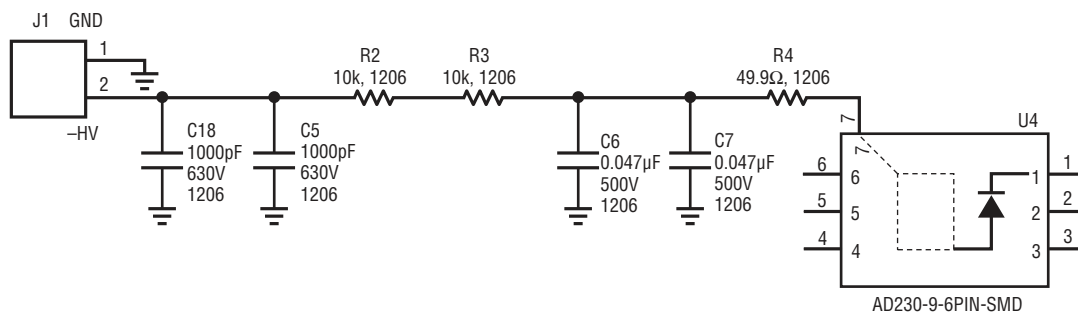

Figure 2. Backside of the DC2803A

INPUT CIRCUIT DESCRIPTION

The APD is DC-coupled to the TIA and is in the common anode configuration. The APD is sensitive from 400nm to

1100nm. The DC2803A implements a simple RC quenching circuit to protect the APD from overload conditions.



DC2803A F03

Figure 3. Input Circuit for DC2803A

OUTPUT CIRCUIT DESCRIPTION

For convenience, the LTC6560 offers two outputs: OUT-TERM pin has an internal series 50Ω source resistor, and OUT pin has a direct connection. The schematic is shown in Figure 4. Only one output can be used to monitor at a time. The DC2803A output stage is AC-coupled 50Ω source to allow for interfacing to 50Ω systems. J2 is

populated by default; this configuration connects to OUT pin on the LTC6560. J3 and its passives can be populated to use OUTTERM pin. The LTC6560 implements a class B output stage, a 1k pull-down resistor on OUTTERM provides a DC path to ground. This helps the LTC6560 output pull to ground when the LTC6560 output is AC-coupled.

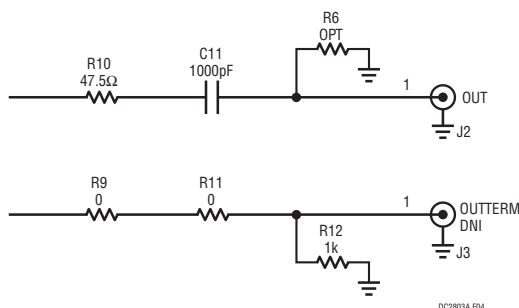

DC2803A F04

Figure 4. Output Circuit for DC2803A

CONNECTING MULTIPLE LTC6560S FOR OUTPUT MUXING

The outputs of the LTC6560 can be wired ORed together to combine multiple inputs. When the O_MUX pin is high, the LTC6560s output goes to a high impedance state. When the O_MUX pin is low, the LTC6560 is enabled. Only one LTC6560 can be enabled at a time. Source resistors are necessary to avoid reflections from the paths that are inactive. Be sure to keep the output lengths as short as possible to mitigate the effects of transmission line stubs. Figure 5 shows how multiple LTC6560 are connected. Both J2 (Out Pin) or J3 (OUTTERM Pin) can be used to implement output MUXing. By replacing C11 with a 0Ω 0402 resistor and removing R12, the output can be DC-coupled to connect multiple DC2803A boards. A DC block can then be used to interface with 50Ω systems.

OMUX SWITCHING

By default, the DC2803A implements a jumper (JP2) to enable (EN) or disable (DIS) the LTC6560. To exercise the full speed of the LTC6560 O_MUX switching, J4 labeled O_MUX can be used to drive the O_MUX pin. R13 will need to be stuffed with a 50Ω 0402 resistor, R14 will need to be removed, and an SMA end connector will need to be soldered to the board.

MEASURING TEMPERATURE

DC2803A includes the option to measure temperature using the TMP36. A turret labeled TMP is connected to the TMP36 output. At 25°C, the TMP36 provides 750mV output and has a scale factor of 10mV/°C. This feature is useful to temperature compensate the APD.

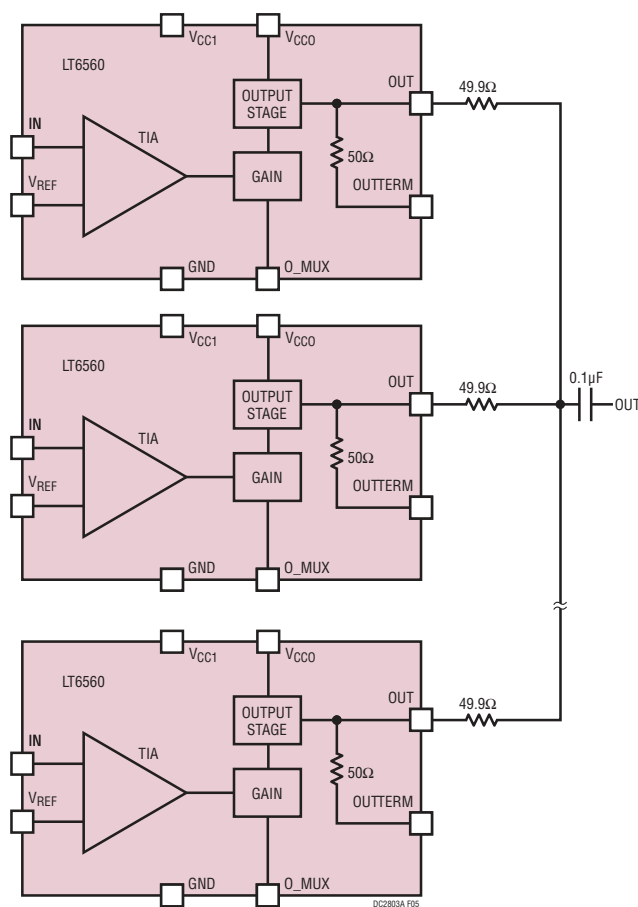
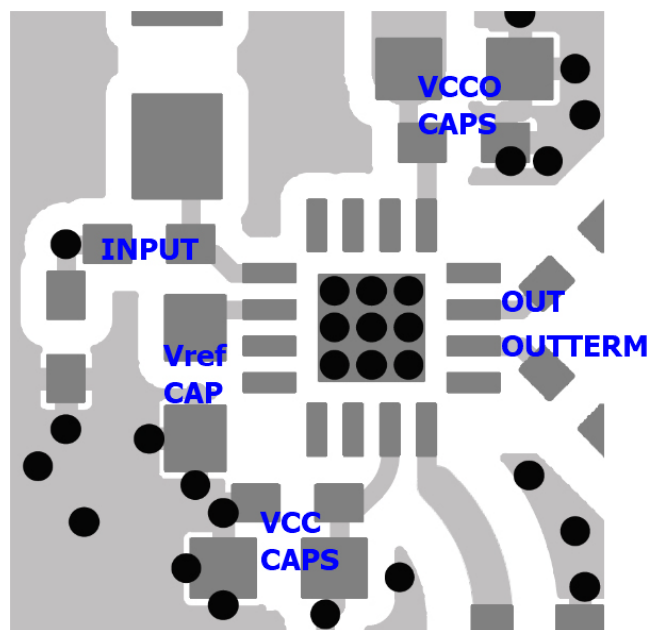

Figure 5. Diagram of Wire ORed Outputs of Multiple LTC6560s

CONNECTING MULTIPLE LTC6560S FOR OUTPUT MUXING

LAYOUT CONSIDERATIONS

The DC2803A layout is optimized to not affect the LTC6560's performance. The V_{REF} capacitor should be orthogonal to the input trace. This orientation helps to reduce coupling from the input to V_{REF} . Local bypass for V_{CCO} and V_{CC} should be as close as possible to the LTC6560. The ground pad in the center of the LTC6560 is important for dissipating the heat from the die. Maximizing the number of vias and employing multiple ground plane layers will most effectively heat sink the LTC6560. Figure 6 shows the DC2803A layout.



DC2803A F06

Figure 6. Recommended Layout

EXTERNAL CONNECTIONS

Connections

J1: 2-pin terminal block. Negative high voltage input for the APD. A maximum of $-200V$ can be applied.

J2: OUT – The analog output of the LTC6560.

J3: OUTTERM – The analog output of the LTC6560 with the internal 50Ω series resistor.

J4: O_MUX – SMA input for the O_MUX PIN. This input is by default not populated. Refer to the OMUX Switching section for proper operation.

Turrets

E1: TMP – TMP36 analog out.

E3: V_{CC} – LTC6560 V_{CC} analog input.

E4–E6: GND

Jumpers

JP2: O_MUX – Enables (EN) or disables (DIS) the LTC6560. The output goes high impedance when the LTC6560 is disabled.



ESD Caution

ESD (electrostatic discharge) sensitive device. Charged devices and circuit boards can discharge without detection. Although this product features patented or proprietary protection circuitry, damage may occur on devices subjected to high energy ESD. Therefore, proper ESD precautions should be taken to avoid performance degradation or loss of functionality.

Legal Terms and Conditions

By using the evaluation board discussed herein (together with any tools, components documentation or support materials, the "Evaluation Board"), you are agreeing to be bound by the terms and conditions set forth below ("Agreement") unless you have purchased the Evaluation Board, in which case the Analog Devices Standard Terms and Conditions of Sale shall govern. Do not use the Evaluation Board until you have read and agreed to the Agreement. Your use of the Evaluation Board shall signify your acceptance of the Agreement. This Agreement is made by and between you ("Customer") and Analog Devices, Inc. ("ADI"), with its principal place of business at One Technology Way, Norwood, MA 02062, USA. Subject to the terms and conditions of the Agreement, ADI hereby grants to Customer a free, limited, personal, temporary, non-exclusive, non-sublicensable, non-transferable license to use the Evaluation Board FOR EVALUATION PURPOSES ONLY. Customer understands and agrees that the Evaluation Board is provided for the sole and exclusive purpose referenced above, and agrees not to use the Evaluation Board for any other purpose. Furthermore, the license granted is expressly made subject to the following additional limitations: Customer shall not (i) rent, lease, display, sell, transfer, assign, sublicense, or distribute the Evaluation Board; and (ii) permit any Third Party to access the Evaluation Board. As used herein, the term "Third Party" includes any entity other than ADI, Customer, their employees, affiliates and in-house consultants. The Evaluation Board is NOT sold to Customer; all rights not expressly granted herein, including ownership of the Evaluation Board, are reserved by ADI. CONFIDENTIALITY. This Agreement and the Evaluation Board shall all be considered the confidential and proprietary information of ADI. Customer may not disclose or transfer any portion of the Evaluation Board to any other party for any reason. Upon discontinuation of use of the Evaluation Board or termination of this Agreement, Customer agrees to promptly return the Evaluation Board to ADI. ADDITIONAL RESTRICTIONS. Customer may not disassemble, decompile or reverse engineer chips on the Evaluation Board. Customer shall inform ADI of any occurred damages or any modifications or alterations it makes to the Evaluation Board, including but not limited to soldering or any other activity that affects the material content of the Evaluation Board. Modifications to the Evaluation Board must comply with applicable law, including but not limited to the RoHS Directive. TERMINATION. ADI may terminate this Agreement at any time upon giving written notice to Customer. Customer agrees to return to ADI the Evaluation Board at that time. LIMITATION OF LIABILITY. THE EVALUATION BOARD PROVIDED HEREUNDER IS PROVIDED "AS IS" AND ADI MAKES NO WARRANTIES OR REPRESENTATIONS OF ANY KIND WITH RESPECT TO IT. ADI SPECIFICALLY DISCLAIMS ANY REPRESENTATIONS, ENDORSEMENTS, GUARANTEES, OR WARRANTIES, EXPRESS OR IMPLIED, RELATED TO THE EVALUATION BOARD INCLUDING, BUT NOT LIMITED TO, THE IMPLIED WARRANTY OF MERCHANTABILITY, TITLE, FITNESS FOR A PARTICULAR PURPOSE OR NON-INFRINGEMENT OF INTELLECTUAL PROPERTY RIGHTS. IN NO EVENT WILL ADI AND ITS LICENSORS BE LIABLE FOR ANY INCIDENTAL, SPECIAL, INDIRECT, OR CONSEQUENTIAL DAMAGES RESULTING FROM CUSTOMER'S POSSESSION OR USE OF THE EVALUATION BOARD, INCLUDING BUT NOT LIMITED TO LOST PROFITS, DELAY COSTS, LABOR COSTS OR LOSS OF GOODWILL. ADI'S TOTAL LIABILITY FROM ANY AND ALL CAUSES SHALL BE LIMITED TO THE AMOUNT OF ONE HUNDRED US DOLLARS (\$100.00). EXPORT. Customer agrees that it will not directly or indirectly export the Evaluation Board to another country, and that it will comply with all applicable United States federal laws and regulations relating to exports. GOVERNING LAW. This Agreement shall be governed by and construed in accordance with the substantive laws of the Commonwealth of Massachusetts (excluding conflict of law rules). Any legal action regarding this Agreement will be heard in the state or federal courts having jurisdiction in Suffolk County, Massachusetts, and Customer hereby submits to the personal jurisdiction and venue of such courts. The United Nations Convention on Contracts for the International Sale of Goods shall not apply to this Agreement and is expressly disclaimed.