

FEATURES

- Eight Low-Side Drivers With Internal Clamp for Inductive Loads and Current Limiting for Self Protection
 - Seven Outputs Rated at 150 mA and Controlled Through Serial Interface
 - One Output Rated at 150 mA and Controlled Through Serial Interface and Dedicated Enable Pin
- 5-V \pm 5% Regulated Power Supply With 200-mA Load Capability at V_{IN} Max of 18 V
- Internal Voltage Supervisory for Regulated Output
- Serial Communications for Control of Eight Low-Side Drivers
- Enable/Disable Input for OUT1
- 5-V or 3.3-V I/O Tolerant for Interface to Microcontroller
- Programmable Power-On Reset Delay Before \overline{RST} Asserted High, Once 5 V Is Within Specified Range (6 ms Typ)
- Programmable Deglitch Timer Before \overline{RST} Asserted Low (40 μ s Typ)
- Zero-Voltage Detection Signal
- Thermal Shutdown for Self Protection

APPLICATIONS

- Electrical Appliances
 - Air Conditioning Units
 - Ranges
 - Dishwashers
 - Refrigerators
 - Microwaves
 - Washing Machines
- General-Purpose Interface Circuits, Allowing Microcontroller Interface to Relays, Electric Motors, LEDs, and Buzzers

N OR PWP PACKAGE
(TOP VIEW)

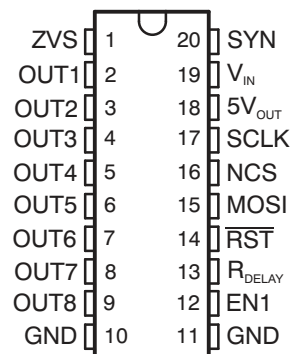

DESCRIPTION/ORDERING INFORMATION

The power supply provides regulated 5-V output to power the system microcontroller and drive eight low-side switches. The ac zero-detect circuitry is monitoring the crossover voltage of the mains ac supply. The resultant signal is a low-frequency clock output on the ZVS terminal, based on the ac-line cycle. This information allows the microcontroller to reduce in-rush current by powering loads on the ac-line peak voltage.

A serial communications interface controls the eight low-side outputs; each output has an internal snubber circuit to absorb the energy in the inductor at turn OFF. Alternatively, the system can use a fly-back diode to V_{IN} to help recirculate the energy in an inductive load at turn OFF.

ORDERING INFORMATION⁽¹⁾

T_A	PACKAGE ⁽²⁾		ORDERABLE PART NUMBER	TOP-SIDE MARKING
–40°C to 125°C	PDIP – N	Tube of 20	TPL9201N	TPL9201N
	PowerPAD™ – PWP	Reel of 2000	TPL9201PWPR	PL201
		Tube of 70	TPL9201PWP	

(1) For the most current package and ordering information, see the Package Option Addendum at the end of this document, or see the TI web site at www.ti.com.

(2) Package drawings, thermal data, and symbolization are available at www.ti.com/packaging.



Please be aware that an important notice concerning availability, standard warranty, and use in critical applications of Texas Instruments semiconductor products and disclaimers thereto appears at the end of this data sheet.

PowerPAD is a trademark of Texas Instruments.

TPL9201

8-CHANNEL RELAY DRIVER WITH INTEGRATED 5-V LDO AND ZERO-VOLT DETECTION

SLIS123D–JUNE 2006–REVISED FEBRUARY 2008

PINOUT CONFIGURATION

NO.	NAME	I/O	DESCRIPTION
1	ZVS	O	Zero-voltage synchronization
2	OUT1	O	Low-side output 1
3	OUT2	O	Low-side output 2
4	OUT3	O	Low-side output 3
5	OUT4	O	Low-side output 4
6	OUT5	O	Low-side output 5
7	OUT6	O	Low-side output 6
8	OUT7	O	Low-side output 7
9	OUT8	O	Low-side output 8
10 ⁽¹⁾	GND	I	Ground
11 ⁽¹⁾	GND	I	Ground
12	EN1	I	Enable/disable for OUT1
13	R _{DELAY}	O	Power-up reset delay
14 ⁽²⁾	$\overline{\text{RST}}$	I/O	Power-on reset output (open drain, active low)
15	MOSI	I	Serial data input
16	NCS	I	Chip select
17	SCLK	I	Serial clock for data synchronization
18	5V _{OUT}	O	Regulated output
19	V _{IN}	I	Unregulated input voltage source
20	SYN	I	AC zero detect input

(1) Terminals 10 and 11 are fused internally in the lead frame for the 20-pin PDIP package.

(2) Terminal 14 can be used as an input or an output.

FUNCTIONAL BLOCK DIAGRAM

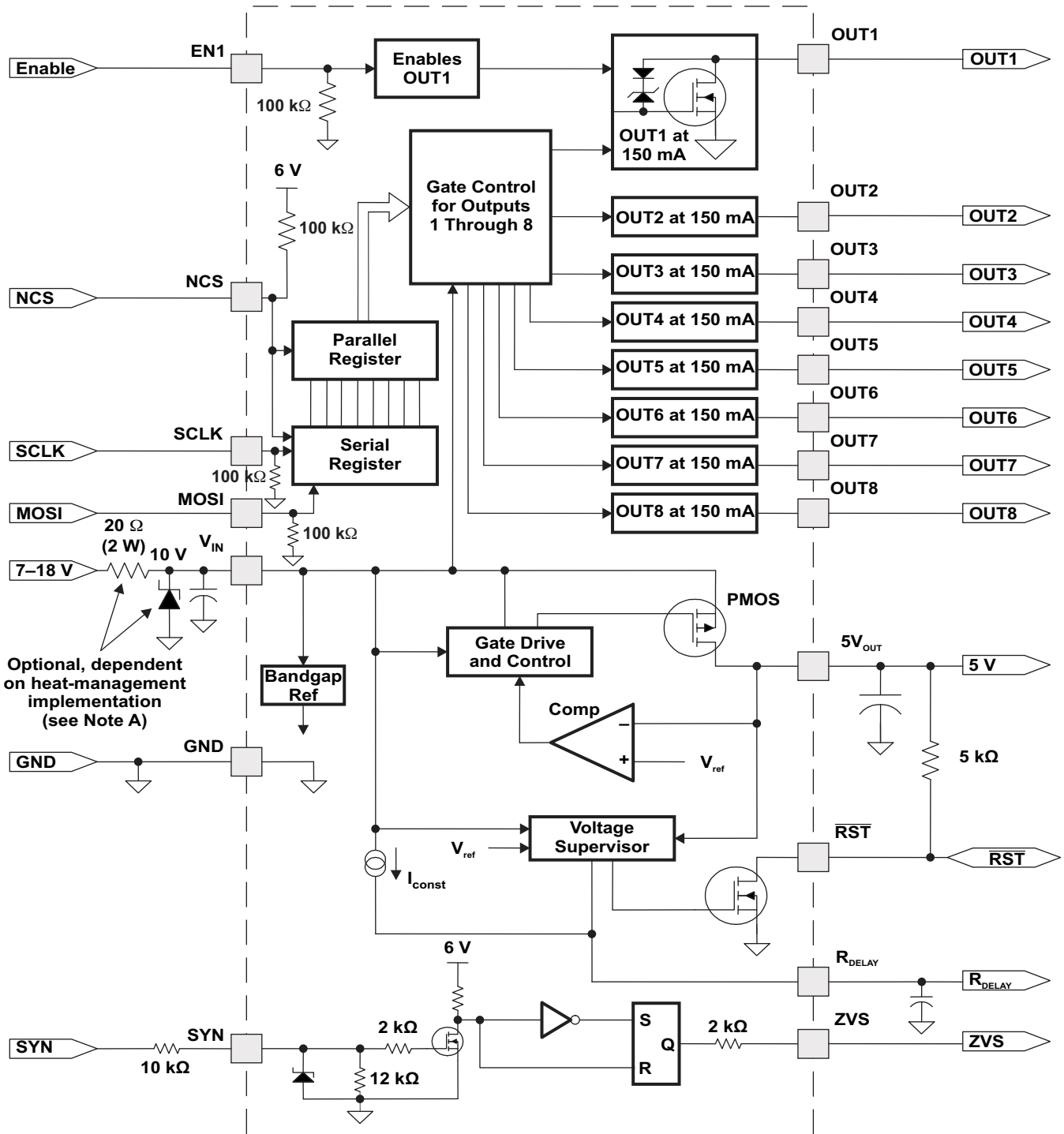

A. The resistor and Zener diode are required if there is insufficient thermal-management allocation.

TPL9201

8-CHANNEL RELAY DRIVER WITH INTEGRATED 5-V LDO AND ZERO-VOLT DETECTION

SLIS123D–JUNE 2006–REVISED FEBRUARY 2008

DETAILED DESCRIPTION

The 5-V regulator is powered from V_{IN} , and the regulated output is within $5\text{ V} \pm 5\%$ over the operating conditions. The open-drain power-on reset (\overline{RST}) pin remains low until the regulator exceeds the set threshold, and the timer value set by the capacitor on the reset delay (R_{DELAY}) pin expires. If both of these conditions are satisfied, \overline{RST} is asserted high. This signifies to the microcontroller that serial communications can be initiated to the TPL9201.

The serial communications is an 8-bit format, with data transfer synchronized using a serial clock from the microcontroller. A single register controls all the outputs (one bit per output). The default value is zero (OFF). If an output requires pulse width modulation (PWM) function, the register must be updated at a rate faster than the desired PWM frequency. OUT1 can be controlled by serial input from the microcontroller or with the dedicated enable (EN1) pin. If EN1 is pulled low or left open, the serial input through the shift register controls OUT1. If EN1 is pulled high, OUT1 always is turned on, and the serial input for OUT1 is ignored.

The SYN input translates the image of the mains voltage through the secondary of the transformer. The SYN input has a resistor to protect from high currents into the IC. The zero-voltage synchronization output translates the ac-line cycle frequency into a low-frequency clock, which can be used for a timing reference and to help power loads on the ac-line peak voltage (to reduce in-rush currents).

If \overline{RST} is asserted, all outputs are turned OFF internally, and the input register is reset to all zeroes. The microcontroller must write to the register to turn the outputs ON again.

Absolute Maximum Ratings⁽¹⁾

			MIN	MAX	UNIT
V _{I(unreg)}	Unregulated input voltage ⁽²⁾ ⁽³⁾	V _{IN}		24	V
		SYN		24	
V _{I(logic)}	Logic input voltage ⁽²⁾ ⁽³⁾	EN1, MOSI, SCLK, and NCS		7	V
		RST and R _{DELAY}		7	
V _O	Low-side output voltage	OUT1–OUT8		16.5	V
I _{LIMIT}	Output current limit ⁽⁴⁾	OUTn = ON and shorted to V _{IN} with low impedance		350	mA
θ _{JA}	Thermal impedance, junction to ambient ⁽⁵⁾	N package		69	°C/W
		PWP package		33	
θ _{JC}	Thermal impedance, junction to case ⁽⁵⁾	N package		54	°C/W
		PWP package		20	
θ _{JP}	Thermal impedance, junction to thermal pad ⁽⁵⁾	PWP package		1.4	°C/W
P _D	Continuous power dissipation ⁽⁶⁾	N package		1.8	W
		PWP package		3.7	
ESD	Electrostatic discharge ⁽⁷⁾			2	kV
T _A	Operating ambient temperature range		–40	125	°C
T _{stg}	Storage temperature range		–65	125	°C
T _{lead}	Lead temperature	Soldering, 10 s		260	°C

- (1) Stresses beyond those listed under "absolute maximum ratings" may cause permanent damage to the device. These are stress ratings only and functional operation of the device at these or any other conditions beyond those indicated under "recommended operating conditions" is not implied. Exposure to absolute-maximum-rated conditions for extended periods may affect device reliability.
- (2) All voltage values are with respect to GND.
- (3) Absolute negative voltage on these pins must not go below –0.5 V.
- (4) Not more than one output should be shorted at a time, and duration of the short circuit should not exceed 1 ms.
- (5) The thermal data is based on using 1-oz copper trace with JEDEC 51-5 test board for PWP and JEDEC 51-7 test board for N.
- (6) The data is based on ambient temperature of 25°C max.
- (7) The Human-Body Model is a 100-pF capacitor discharged through a 1.5-kΩ resistor into each pin.

Dissipation Ratings

PACKAGE	T _A ≤ 25°C POWER RATING	DERATING FACTOR ABOVE T _A = 25°C	T _A = 125°C POWER RATING
N	1812 mW	14.5 mW/°C	362 mW
PWP	3787 mW	30.3 mW/°C	757 mW

Recommended Operating Conditions

			MIN	MAX	UNIT
V _{I(unreg)}	Unregulated input voltage	V _{IN}	7	18	V
		SYN	0	18	
V _{I(logic)}	Logic input voltage	EN1, MOSI, SCLK, NCS, RST, and R _{DELAY}	0	5.25	V
T _A	Operating ambient temperature		–40	125	°C

TPL9201

8-CHANNEL RELAY DRIVER

WITH INTEGRATED 5-V LDO AND ZERO-VOLT DETECTION

SLIS123D–JUNE 2006–REVISED FEBRUARY 2008

Electrical Characteristics

$T_A = -40^\circ\text{C}$ to 125°C , $V_{IN} = 7\text{ V}$ to 18 V (unless otherwise noted)

PARAMETER	TEST CONDITIONS	MIN	TYP ⁽¹⁾	MAX	UNIT		
Supply Voltage and Current							
V_{IN} ⁽²⁾	Input voltage	7		18	V		
I_{VIN}	Input supply current	Enable = ON, OUT1–OUT8 = Off		3	mA		
		Enable = ON, OUT1–OUT8 = On		5			
Logic Inputs (MOSI, NCS, SCLK, and EN1)							
V_{IL}	Logic input low level	$I_{IL} = 100\ \mu\text{A}$		0.8	V		
V_{IH}	Logic input high level	$I_{IL} = 100\ \mu\text{A}$		2.4			
Reset (RST)							
V_{OL}	Low-level logic output	$I_{OL} = 1.6\ \text{mA}$		0.4	V		
V_{OH} ⁽³⁾	High-level logic output	5-k Ω pullup to V_{CC}		$V_{CC} - 0.8$	V		
V_H	Disabling reset threshold	5-V regulator ramps up		4.25	4.5	V	
V_L	Enabling reset threshold	5-V regulator ramps down		3.3	3.75	V	
V_{HYS}	Threshold hysteresis			0.12	0.5	V	
Reset Delay (R_{DELAY})							
I_{OUT}	Output current			18	28	48	μA
T_{DW}	Reset delay timer	$C = 47\ \text{nF}$		3	6		ms
T_{UP}	Reset capacitor to low level	$C = 47\ \text{nF}$		45			μs
Output (OUT1–OUT8)							
V_{OL}	Output ON	$I_{OUTn} = 150\ \text{mA}$		0.4	0.7		V
I_{OH}	Output leakage	$V_{OH} = \text{Max of } 16.5\ \text{V}$		2			μA
Regulator Output (5V_{OUT})							
5V _{OUT}	Output supply	$I_{5VOUT} = 5\ \text{mA}$ to $200\ \text{mA}$, $V_{IN} = 7\ \text{V}$ to $18\ \text{V}$, $C_{5VOUT} = 1\ \mu\text{F}$		4.75	5	5.25	V
I_{5VOUT} limit	Output short-circuit current	$5V_{OUT} = 0\ \text{V}$		200			mA
Thermal Shutdown							
T_{SD}	Thermal shutdown			150			$^\circ\text{C}$
T_{HYS}	Hysteresis			20			$^\circ\text{C}$
Zero Voltage Synchronization (ZVS)							
V_{SYNTH}	Transition threshold			0.4	0.75	1.1	V
I_{SYN}	Input activating current	$R_{ZV} = 10\ \text{k}\Omega$, $V_{SYN} = 24\ \text{V}$		2			mA
t_D	Transition time	Rising and falling		10			μs

(1) All typical values are at $T_A = 25^\circ\text{C}$.

(2) There are external high-frequency noise-suppression capacitors and filter capacitors on V_{IN} .

(3) V_{CC} is the pullup resistor voltage.

Output Control Register

MSB						LSB	
IN8	IN7	IN6	IN5	IN4	IN3	IN2	IN1
0	0	0	0	0	0	0	0

INn = 0: Output OFF

INn = 1: Output ON

To operate the output in PWM mode, the output control register must be updated at a rate twice the desired PWM frequency of the output. Maximum PWM frequency is 5 kHz. The register is updated every 100 μ s.

ENABLE TRUTH TABLE

EN1	SERIAL INPUT FOR OUT1	OUT1
Open	H	On
Open	L	Off
L	H	On
L	L	Off
H	H	On
H	L	On

TPL9201

8-CHANNEL RELAY DRIVER

WITH INTEGRATED 5-V LDO AND ZERO-VOLT DETECTION

SLIS123D–JUNE 2006–REVISED FEBRUARY 2008

Serial Communications Interface

The serial communications is an 8-bit format, with data transfer synchronized using a serial clock from the microcontroller (see [Figure 1](#)). A single register controls all the outputs. The signal gives the instruction to control the output of TPL9201.

The NCS signal enables the SCLK and MOSI data when it is low. After NCS is set low for T_1 , synchronization clock and data begin to transmit and, after the 8-bit data has been transmitted, NCS is set high again to disable SCLK and MOSI and transfer the serial data to the control register. SCLK must be held low when NCS is in the high state.

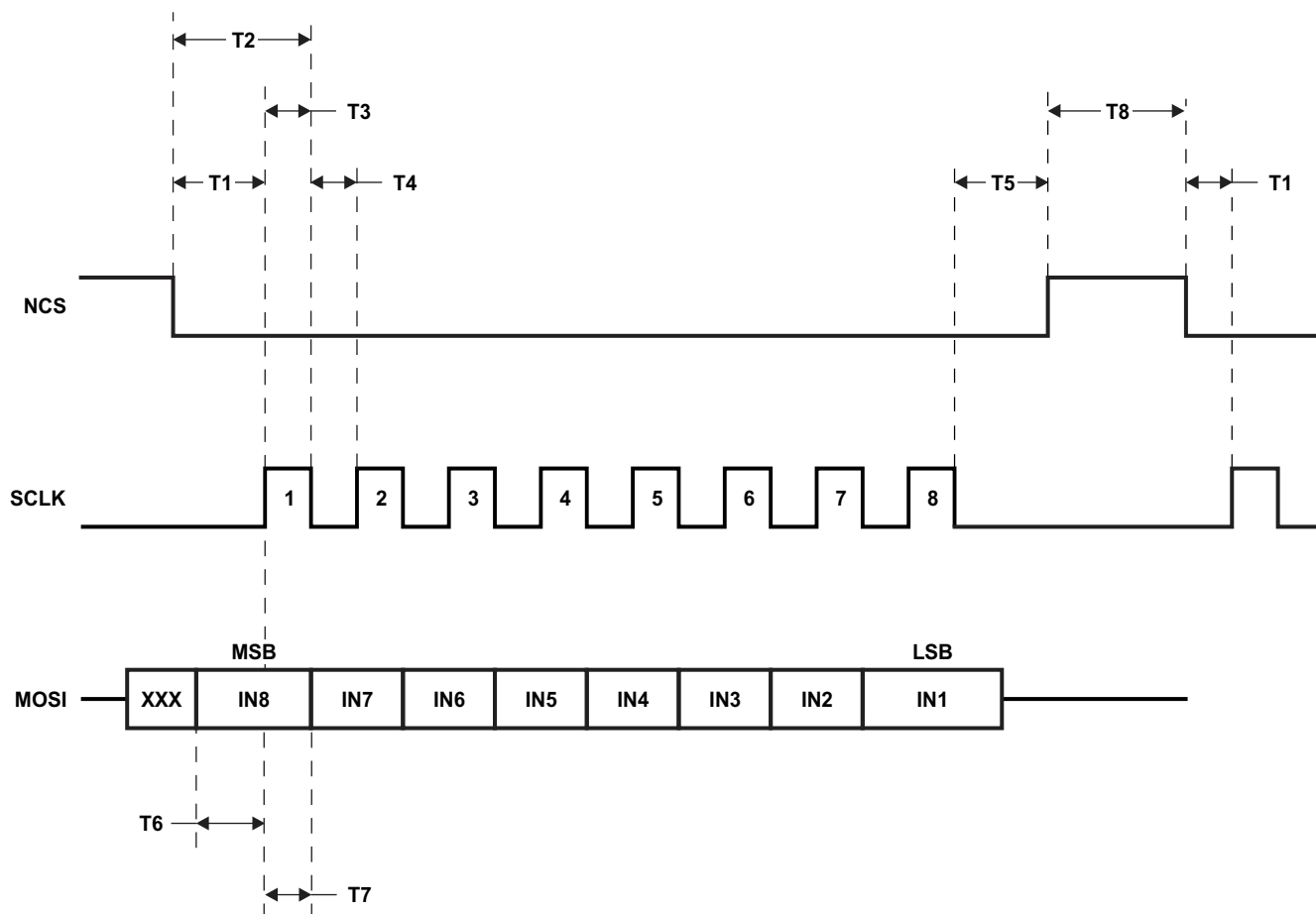

Figure 1. Serial Communications

Timing Requirements

$T_A = -40^\circ\text{C}$ to 125°C , $V_{IN} = 7\text{ V}$ to 18 V (unless otherwise noted)

		MIN	TYP	MAX	UNIT
f_{SPI}	SPI frequency		4		MHz
T1	Delay time, NCS falling edge to SCLK rising edge	10			ns
T2	Delay time, NCS falling edge to SCLK falling edge	80			ns
T3	Pulse duration, SCLK high	60			ns
T4	Pulse duration, SCLK low	60			ns
T5	Delay time, last SCLK falling edge to NCS rising edge	80			ns
T6	Setup time, MOSI valid before SCLK edge	10			ns
T7	Hold time, MOSI valid after SCLK edge	10			ns
T8	Time between two words for transmitting	170			ns

Reset Delay (R_{DELAY})

The R_{DELAY} output provides a constant current source to charge an external capacitor to approximately 6.5 V. The external capacitor is selected to provide a delay time, based on the current equation for a capacitor, $I = C(\Delta v/\Delta t)$ and a 28- μA typical output current.

Therefore, the user should select a 47-nF capacitor to provide a 6-ms delay at 3.55 V.

$$I = C(\Delta v/\Delta t)$$

$$28\ \mu\text{A} = C \times (3.55\ \text{V}/6\ \text{ms})$$

$$C = 47\ \text{nF}$$

TPL9201 8-CHANNEL RELAY DRIVER WITH INTEGRATED 5-V LDO AND ZERO-VOLT DETECTION

SLIS123D—JUNE 2006—REVISED FEBRUARY 2008

APPLICATION INFORMATION

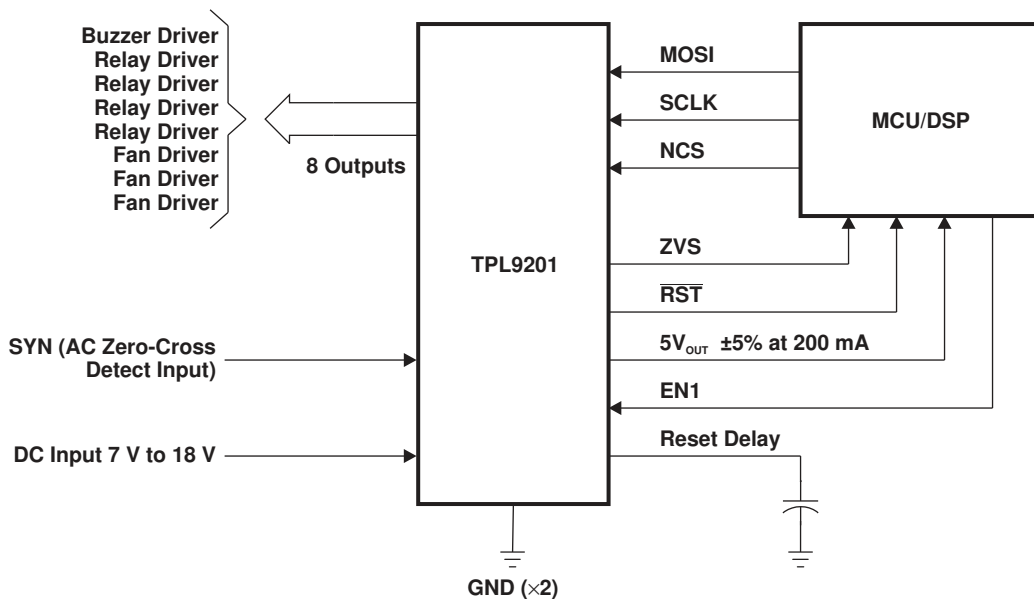

Figure 2. Typical Application

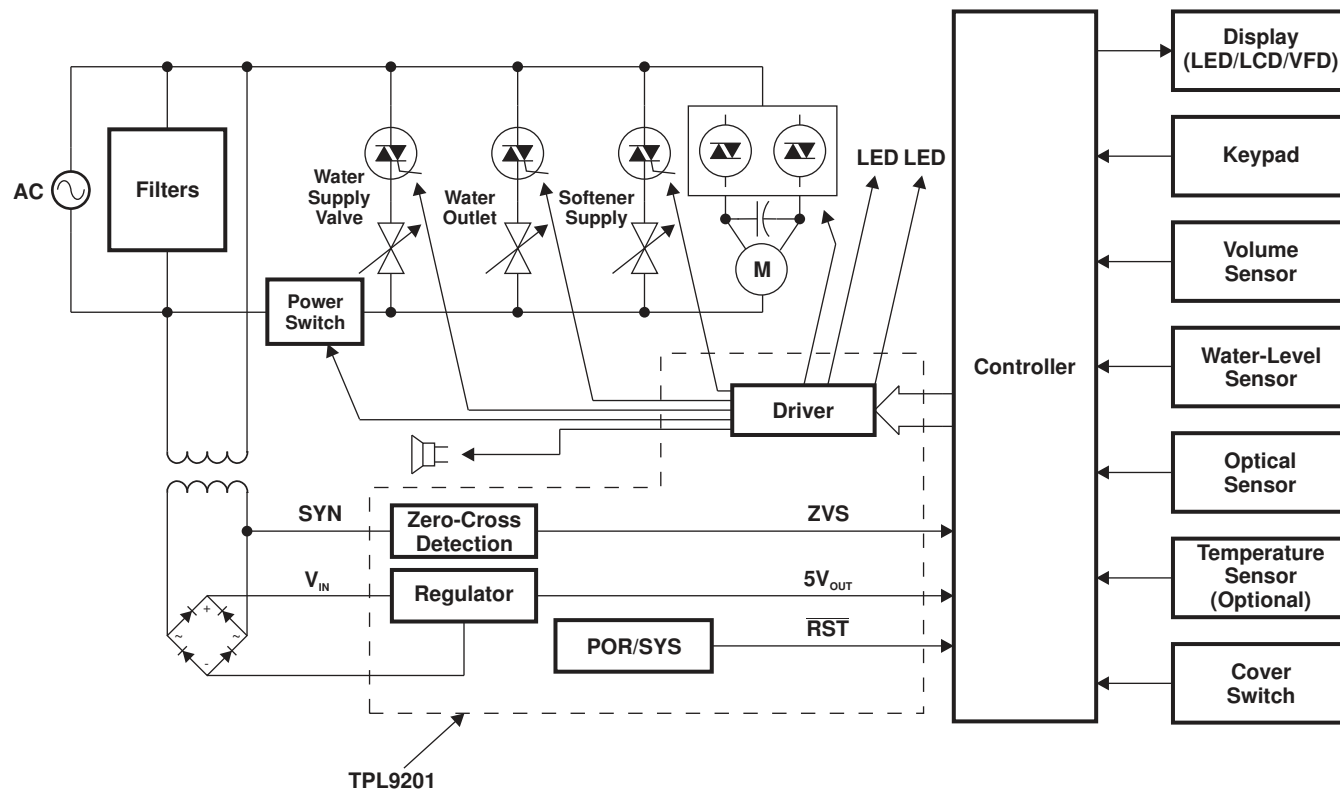

Figure 3. Washing-Machine Application

PCB Layout

To maximize the efficiency of this package for application on a single-layer or multilayer PCB, certain guidelines must be followed when laying out this part on the PCB.

The following information is to be used as a guideline only.

For further information, see the PowerPAD concept implementation document.

Application Using a Multilayer PCB

In a multilayer board application, the thermal vias are the primary method of heat transfer from the package thermal pad to the internal ground plane (see [Figure 4](#) and [Figure 5](#)).

The efficiency of this method depends on several factors: die area, number of thermal vias, thickness of copper, etc. (see the *PowerPAD™ Thermally Enhanced Package Technical Brief*, literature number [SLMA002](#)).

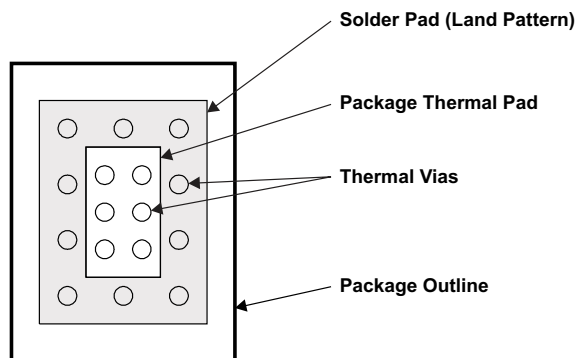

Figure 4. Package and PCB Land Configuration for a Multilayer PCB

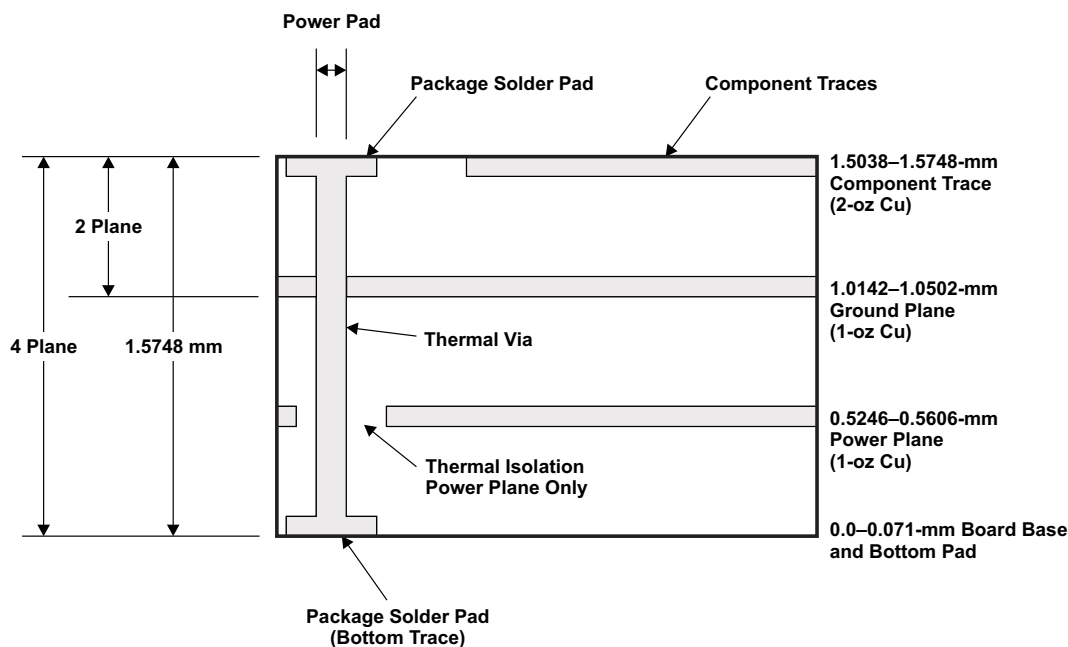

Figure 5. Multilayer Board (Side View)

Application Using a Single-Layer PCB

In a single-layer board application, the thermal pad is attached to a heat spreader (copper area) by using the low thermal-impedance attachment method (solder paste or thermal-conductive epoxy). With either method, it is advisable to use as much copper trace area as possible to dissipate the heat.

TPL9201
8-CHANNEL RELAY DRIVER
WITH INTEGRATED 5-V LDO AND ZERO-VOLT DETECTION

SLIS123D–JUNE 2006–REVISED FEBRUARY 2008

CAUTION:

If the attachment method is not implemented correctly, the functionality of the product cannot be ensured. Power-dissipation capability is adversely affected if the device is incorrectly mounted onto the circuit board.

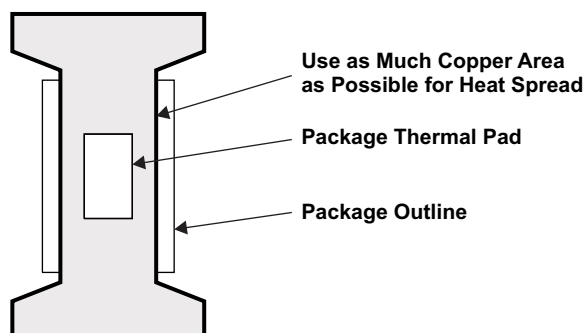

Figure 6. Layout Recommendations for a Single-Layer PCB

Recommended Board Layout

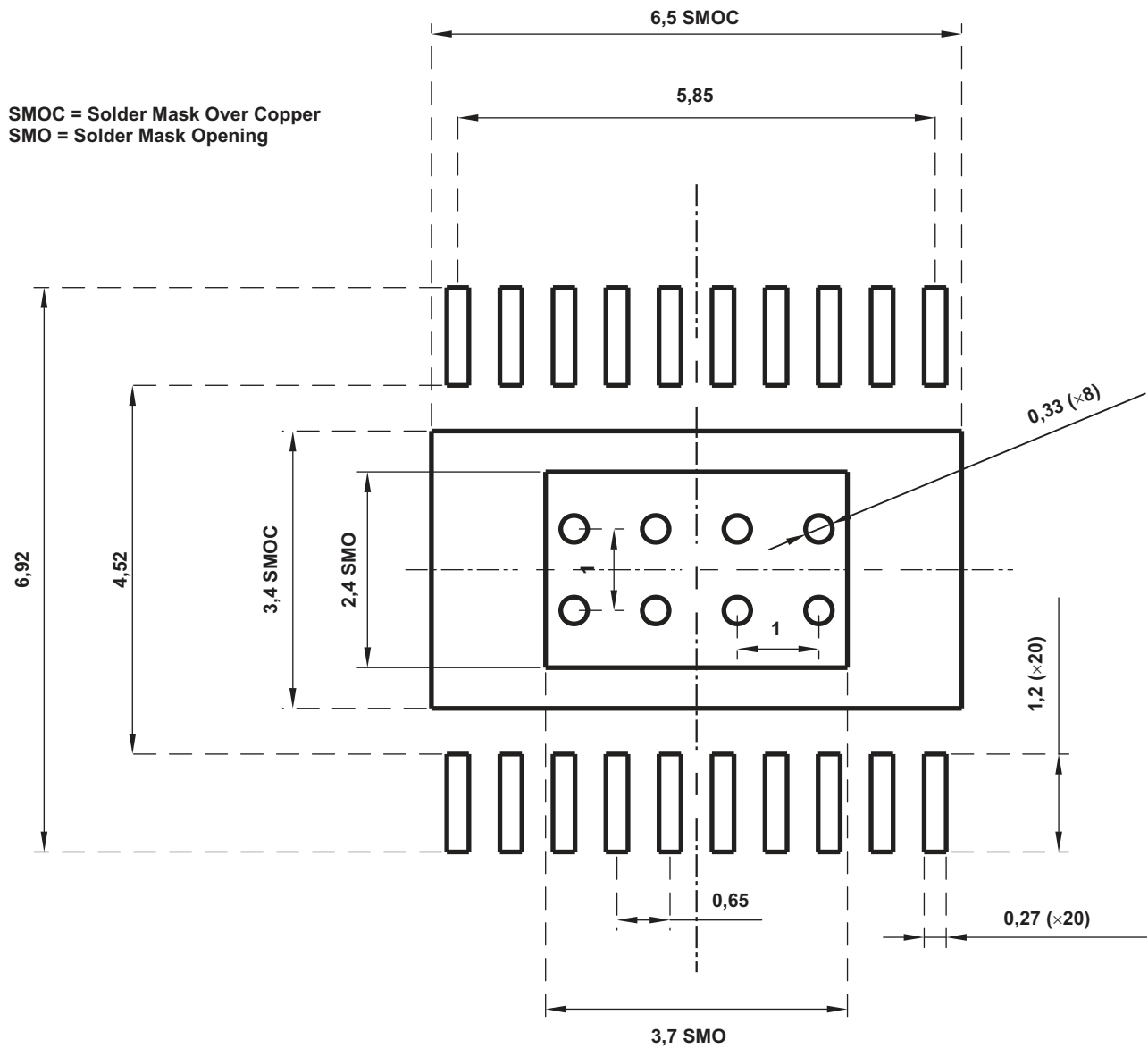

Figure 7. Recommended Board Layout for PWP

PACKAGING INFORMATION

Orderable Device	Status (1)	Package Type	Package Drawing	Pins	Package Qty	Eco Plan (2)	Lead finish/ Ball material (6)	MSL Peak Temp (3)	Op Temp (°C)	Device Marking (4/5)	Samples
TPL9201PWP	ACTIVE	HTSSOP	PWP	20	70	RoHS & Green	NIPDAU	Level-2-260C-1 YEAR	-40 to 125	PL201	Samples
TPL9201PWPR	ACTIVE	HTSSOP	PWP	20	2000	RoHS & Green	NIPDAU	Level-2-260C-1 YEAR	-40 to 125	PL201	Samples

(1) The marketing status values are defined as follows:

ACTIVE: Product device recommended for new designs.

LIFEBUY: TI has announced that the device will be discontinued, and a lifetime-buy period is in effect.

NRND: Not recommended for new designs. Device is in production to support existing customers, but TI does not recommend using this part in a new design.

PREVIEW: Device has been announced but is not in production. Samples may or may not be available.

OBSOLETE: TI has discontinued the production of the device.

(2) **RoHS:** TI defines "RoHS" to mean semiconductor products that are compliant with the current EU RoHS requirements for all 10 RoHS substances, including the requirement that RoHS substance do not exceed 0.1% by weight in homogeneous materials. Where designed to be soldered at high temperatures, "RoHS" products are suitable for use in specified lead-free processes. TI may reference these types of products as "Pb-Free".

RoHS Exempt: TI defines "RoHS Exempt" to mean products that contain lead but are compliant with EU RoHS pursuant to a specific EU RoHS exemption.

Green: TI defines "Green" to mean the content of Chlorine (Cl) and Bromine (Br) based flame retardants meet JS709B low halogen requirements of <=1000ppm threshold. Antimony trioxide based flame retardants must also meet the <=1000ppm threshold requirement.

(3) MSL, Peak Temp. - The Moisture Sensitivity Level rating according to the JEDEC industry standard classifications, and peak solder temperature.

(4) There may be additional marking, which relates to the logo, the lot trace code information, or the environmental category on the device.

(5) Multiple Device Markings will be inside parentheses. Only one Device Marking contained in parentheses and separated by a "~" will appear on a device. If a line is indented then it is a continuation of the previous line and the two combined represent the entire Device Marking for that device.

(6) Lead finish/Ball material - Orderable Devices may have multiple material finish options. Finish options are separated by a vertical ruled line. Lead finish/Ball material values may wrap to two lines if the finish value exceeds the maximum column width.

Important Information and Disclaimer:The information provided on this page represents TI's knowledge and belief as of the date that it is provided. TI bases its knowledge and belief on information provided by third parties, and makes no representation or warranty as to the accuracy of such information. Efforts are underway to better integrate information from third parties. TI has taken and continues to take reasonable steps to provide representative and accurate information but may not have conducted destructive testing or chemical analysis on incoming materials and chemicals. TI and TI suppliers consider certain information to be proprietary, and thus CAS numbers and other limited information may not be available for release.

In no event shall TI's liability arising out of such information exceed the total purchase price of the TI part(s) at issue in this document sold by TI to Customer on an annual basis.

TAPE AND REEL INFORMATION

QUADRANT ASSIGNMENTS FOR PIN 1 ORIENTATION IN TAPE

*All dimensions are nominal

Device	Package Type	Package Drawing	Pins	SPQ	Reel Diameter (mm)	Reel Width W1 (mm)	A0 (mm)	B0 (mm)	K0 (mm)	P1 (mm)	W (mm)	Pin1 Quadrant
TPL9201PWPR	HTSSOP	PWP	20	2000	330.0	16.4	6.95	7.1	1.6	8.0	16.0	Q1

TAPE AND REEL BOX DIMENSIONS

*All dimensions are nominal

Device	Package Type	Package Drawing	Pins	SPQ	Length (mm)	Width (mm)	Height (mm)
TPL9201PWPR	HTSSOP	PWP	20	2000	350.0	350.0	43.0

TUBE



*All dimensions are nominal

Device	Package Name	Package Type	Pins	SPQ	L (mm)	W (mm)	T (μm)	B (mm)
TPL9201PWP	PWP	HTSSOP	20	70	530	10.2	3600	3.5

MECHANICAL DATA

PWP (R-PDSO-G20)

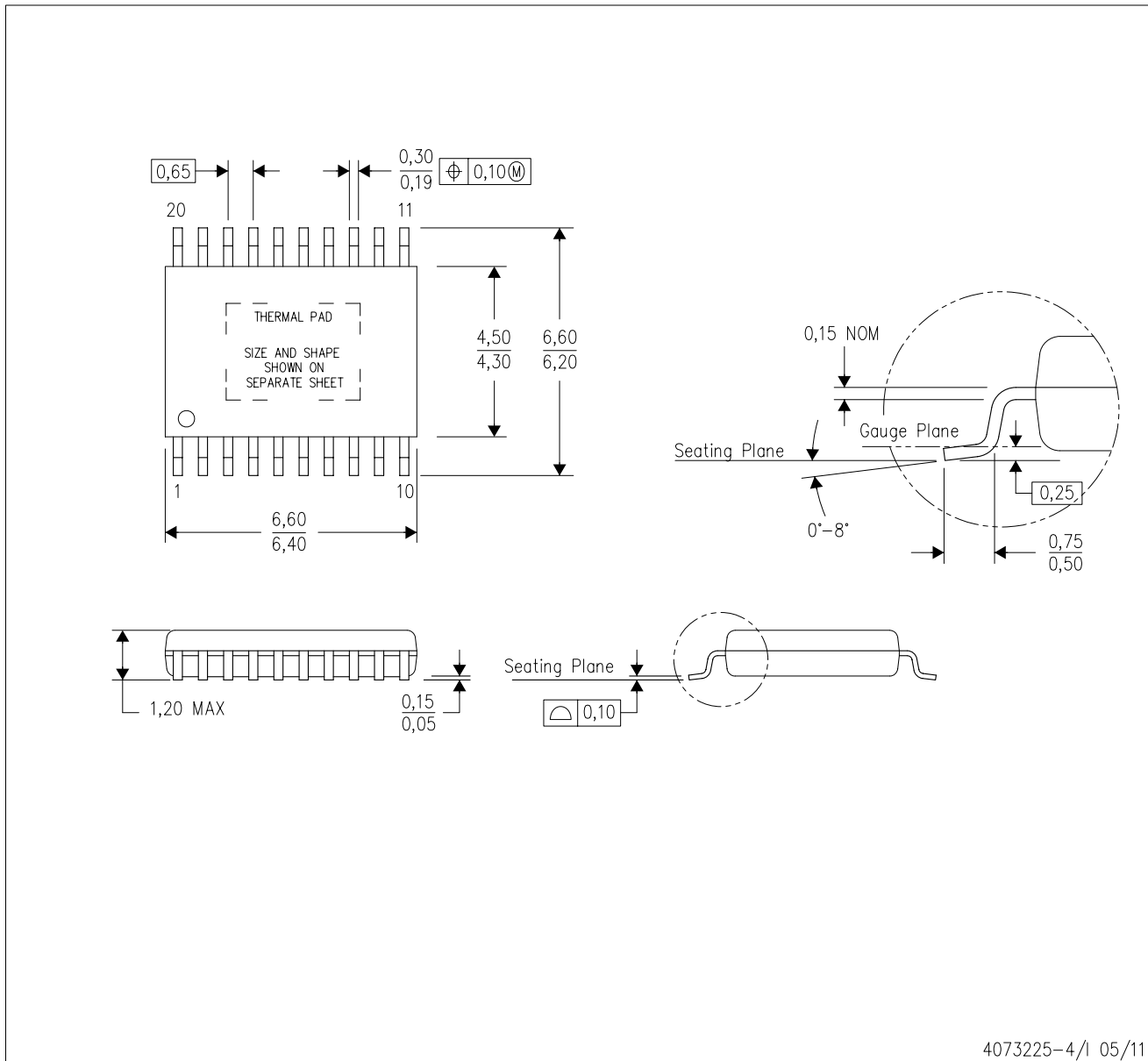
PowerPAD™ PLASTIC SMALL OUTLINE



4073225-4/1 05/11

- NOTES:
- All linear dimensions are in millimeters.
 - This drawing is subject to change without notice.
 - Body dimensions do not include mold flash or protrusions. Mold flash and protrusion shall not exceed 0.15 per side.
 - This package is designed to be soldered to a thermal pad on the board. Refer to Technical Brief, PowerPad Thermally Enhanced Package, Texas Instruments Literature No. SLMA002 for information regarding recommended board layout. This document is available at www.ti.com <<http://www.ti.com>>.
 - See the additional figure in the Product Data Sheet for details regarding the exposed thermal pad features and dimensions.
 - Falls within JEDEC MO-153

PowerPAD is a trademark of Texas Instruments.

THERMAL PAD MECHANICAL DATA

PWP (R-PDSO-G20) PowerPAD™ SMALL PLASTIC OUTLINE

THERMAL INFORMATION

This PowerPAD™ package incorporates an exposed thermal pad that is designed to be attached to a printed circuit board (PCB). The thermal pad must be soldered directly to the PCB. After soldering, the PCB can be used as a heatsink. In addition, through the use of thermal vias, the thermal pad can be attached directly to the appropriate copper plane shown in the electrical schematic for the device, or alternatively, can be attached to a special heatsink structure designed into the PCB. This design optimizes the heat transfer from the integrated circuit (IC).

For additional information on the PowerPAD package and how to take advantage of its heat dissipating abilities, refer to Technical Brief, PowerPAD Thermally Enhanced Package, Texas Instruments Literature No. SLMA002 and Application Brief, PowerPAD Made Easy, Texas Instruments Literature No. SLMA004. Both documents are available at www.ti.com.

The exposed thermal pad dimensions for this package are shown in the following illustration.

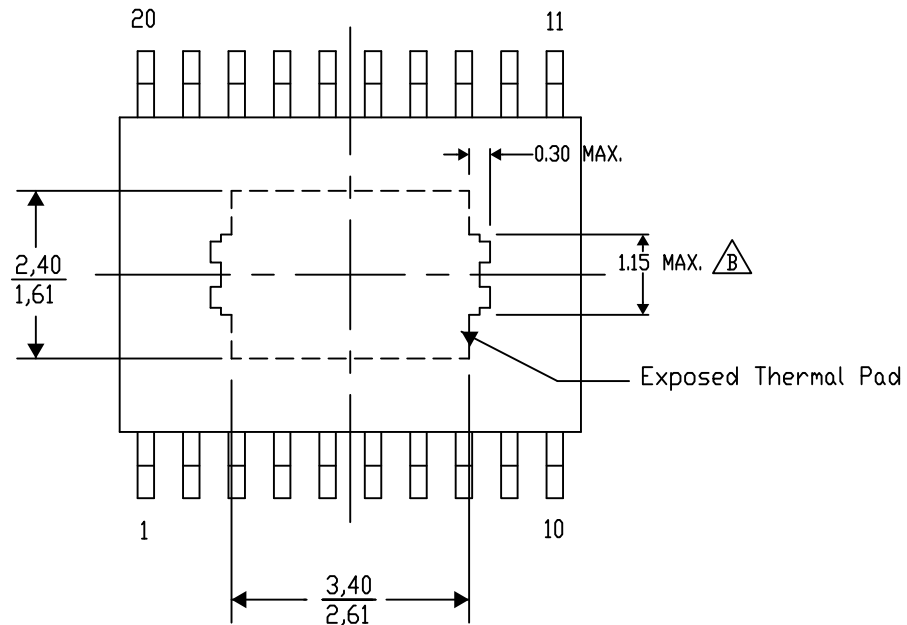

Top View

Exposed Thermal Pad Dimensions

4206332-15/AO 01/16

NOTE: A. All linear dimensions are in millimeters

 Exposed tie strap features may not be present.

PowerPAD is a trademark of Texas Instruments

PWP (R-PDSO-G20)

PowerPAD™ PLASTIC SMALL OUTLINE

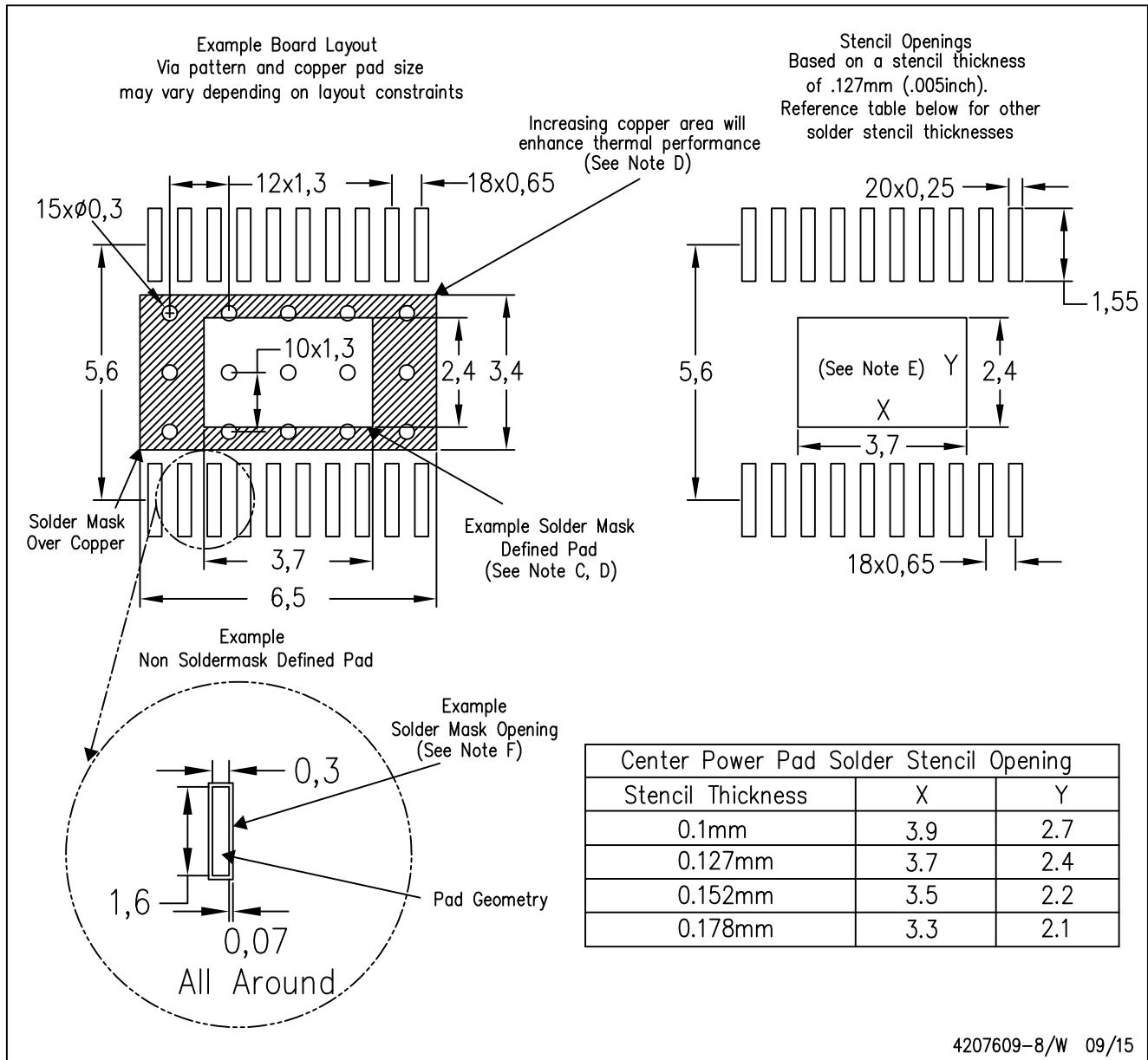

- NOTES:
- A. All linear dimensions are in millimeters.
 - B. This drawing is subject to change without notice.
 - C. Customers should place a note on the circuit board fabrication drawing not to alter the center solder mask defined pad.
 - D. This package is designed to be soldered to a thermal pad on the board. Refer to Technical Brief, PowerPad Thermally Enhanced Package, Texas Instruments Literature No. SLMA002, SLMA004, and also the Product Data Sheets for specific thermal information, via requirements, and recommended board layout. These documents are available at www.ti.com <<http://www.ti.com>>. Publication IPC-7351 is recommended for alternate designs.
 - E. Laser cutting apertures with trapezoidal walls and also rounding corners will offer better paste release. Customers should contact their board assembly site for stencil design recommendations. Example stencil design based on a 50% volumetric metal load solder paste. Refer to IPC-7525 for other stencil recommendations.
 - F. Customers should contact their board fabrication site for solder mask tolerances between and around signal pads.

IMPORTANT NOTICE AND DISCLAIMER

TI PROVIDES TECHNICAL AND RELIABILITY DATA (INCLUDING DATA SHEETS), DESIGN RESOURCES (INCLUDING REFERENCE DESIGNS), APPLICATION OR OTHER DESIGN ADVICE, WEB TOOLS, SAFETY INFORMATION, AND OTHER RESOURCES "AS IS" AND WITH ALL FAULTS, AND DISCLAIMS ALL WARRANTIES, EXPRESS AND IMPLIED, INCLUDING WITHOUT LIMITATION ANY IMPLIED WARRANTIES OF MERCHANTABILITY, FITNESS FOR A PARTICULAR PURPOSE OR NON-INFRINGEMENT OF THIRD PARTY INTELLECTUAL PROPERTY RIGHTS.

These resources are intended for skilled developers designing with TI products. You are solely responsible for (1) selecting the appropriate TI products for your application, (2) designing, validating and testing your application, and (3) ensuring your application meets applicable standards, and any other safety, security, regulatory or other requirements.

These resources are subject to change without notice. TI grants you permission to use these resources only for development of an application that uses the TI products described in the resource. Other reproduction and display of these resources is prohibited. No license is granted to any other TI intellectual property right or to any third party intellectual property right. TI disclaims responsibility for, and you will fully indemnify TI and its representatives against, any claims, damages, costs, losses, and liabilities arising out of your use of these resources.

TI's products are provided subject to [TI's Terms of Sale](#) or other applicable terms available either on ti.com or provided in conjunction with such TI products. TI's provision of these resources does not expand or otherwise alter TI's applicable warranties or warranty disclaimers for TI products.

TI objects to and rejects any additional or different terms you may have proposed.

Mailing Address: Texas Instruments, Post Office Box 655303, Dallas, Texas 75265
Copyright © 2022, Texas Instruments Incorporated