

NOTES:

1. THIS PROTECTIVE COVER IS DESIGNED TO PROTECT THE INTERFACE OF MTC100 PLUG CONNECTORS. THE PARTS ALSO OFFER ELECTROMAGNETIC EMISSION PROTECTION.

2. MATING TORQUE

FOR PROPER MATING CONDITION, SCREWS MUST BE EQUALLY TIGHTENED AND LOOSENED BY ONE HALF TURN A TIME TO PREVENT ANY DAMAGES TO THE MATING GASKET. RETENTION SCREWS ARE TO BE TORQUED TO 7±0.5 in-lbs.

3. MATERIAL:

- a. HOUSING ALUMINUM ALLOY PER QQ-A-601 OR QQ-A-225
- b. ADAPTER SCREW STAINLESS STEEL PER QQ-S-763
- c. GASKET CONDUCTIVE FLUOROSILICONE ELASTOMER
- d. FLAT WASHER STAINLESS STEEL PER QQ-S-766
- e. ADAPTER NUT STAINLESS STEEL PER QQ-S-766
- f. PANEL WASHER STAINLESS STEEL PER QQ-S-766
- g. LANYARD STAINLESS STEEL PER QQ-S-766

4. FINISH:

- a. HOUSING CADMIUM PLATE PER QQ-P-416 OVER NICKEL UNDERPLATE
- b. ADAPTER SCREW CADMIUM PLATE PER QQ-P-416
- c. FLAT WASHER CADMIUM PLATE PER QQ-P-416
- d. ADAPTER NUT CADMIUM PLATE PER QQ-P-416
- e. PANEL WASHER CADMIUM PLATE PER QQ-P-416
- f. LANYARD CADMIUM PLATE PER QQ-P-416

5. "RAYCHEM", PART NUMBER AND DATE CODE STAMPED APPROXIMATELY AS SHOWN. SEE TABULATION FOR APPROPRIATE PART NUMBER.

REVISIONS			
LTR	DESCRIPTION	DATE	APPROVED
A	REVISED PER ECN T-30358	12/4/2001	M.HIGGY

**If this document is printed it becomes uncontrolled.
Check with the web for latest revision.**

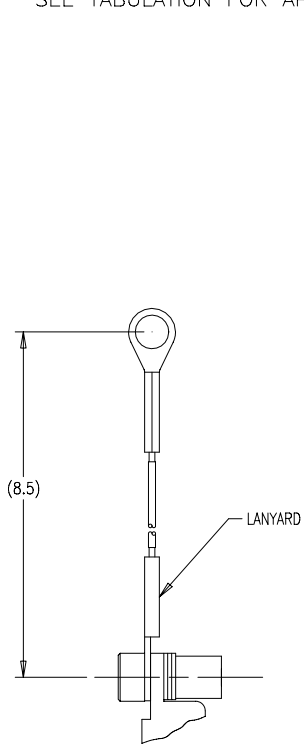

DETAIL A
FOR CHA-0157-009 PART ONLY

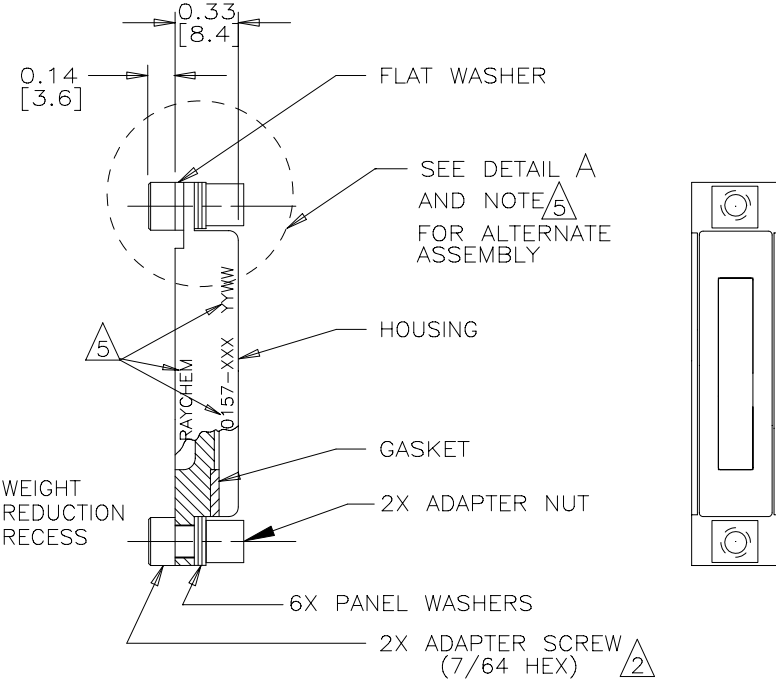
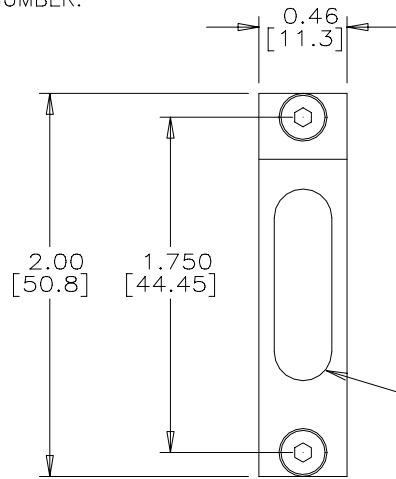

5 PART NUMBER	DESCRIPTION	WEIGHT (MAXIMUM)
CHA-0157	WITHOUT LANYARD	.068 LBS. [30.7 gr.]
CHA-0157-009	WITH LANYARD PER DETAIL A	.073 LBS. [33.0 gr.]

SPECIFICATION CONTROL DRAWING

UNLESS OTHERWISE SPECIFIED DIMENSIONS ARE IN INCHES. METRIC DIMENSIONS ARE IN BRACKETS. DECIMALS .XXX ±.010 { .25 mm } .XX ±.02 { .5 mm } ANGLES .X ± WEIGHT SEE TABULATION	DRAWN	ZS.ORBAN	11/16/2001	tyco /Electronics/Raychem	WIRE AND HARNESSING PRODUCTS 307 CONSTITUTION DRIVE MENLO PARK, CALIFORNIA 94025			
	CHECKED				TITLE	COVER, PROTECTIVE, RECEPTACLE TYPE, 1", EME COMPATIBLE MTC100 SERIES		
	APPROVED				SIZE	CODE IDENT. NO.	DWG. NO.	REV
	APPROVED	M.HIGGY	11/16/2001	CAD NAME	A	06090	CHA-0157-XXX	A
	THIRD ANGLE PROJECTION	T30358.DWG		DO NOT SCALE THIS DRAWING		SHEET 1 OF 1		

DWG NO. CHA-0157-XXX SHEET