

## Airborne™ Enterprise Class Wireless Device Server

### Serial to 802.11b/g & Ethernet to 802.11b/g

WLANG-XX-DP501 Series



Airborne™ is a line of highly integrated 802.11 radios and device servers, designed to address the demands of complex machine-to-machine (M2M) applications. Utilizing the latest 802.11, microprocessor and network technologies, the Airborne family of products provide a broad encompassing solution for wireless applications requiring performance, reliability and advanced security.

The Airborne Wireless Device Server family includes hardware and software necessary to connect a serial or Ethernet device to a high performance 802.11 network. The WLANG-XX-DP501 series includes a full featured 802.11b/g radio and a high performance 32bit ARM9 processor running an embedded RTOS. The module also incorporates Quatech's exclusive Airborne Device Server firmware, which can network-enable virtually any OEM product.

#### Enterprise Class Security

WPA2 Enterprise (AES-CCMP + EAP) is the emerging standard for leading edge enterprise networks. The Airborne Enterprise Device Server supports the latest security standards and is fully compliant to the WPA2 Enterprise specification. A wide range of EAP supplicants and legacy security standards such as WPA, WEP and LEAP are also supported. The new 802.11b/g module supports 802.11i, 802.1x, WPA2-PSK, WPA2-Enterprise with Certificates, WPA-PSK, WPA-LEAP and WEP.

#### Reliability

Designed by Quatech specifically to meet the demands of the industrial, automotive and medical markets, the Airborne device server has the widest operating temperature range and highest level of reliability available, all backed by a five year limited warranty. Quatech also provides FCC Modular certification, minimizing requirements for further regulatory testing by original equipment manufacturers.

#### Markets

Previous generations of Airborne device servers have been integrated and deployed into a wide range of applications across various industries including:

- Medical equipment
- Vehicle telematics & diagnostics
- Material handling & logistics
- Industrial Automation
- Test & measurement
- Security & access control

Quatech's Airborne Enterprise Device Server Module extends the reputation of the family further by drawing on experience of Quatech application engineers across hundreds of wireless M2M deployments. The advanced technologies implemented in the Quatech Enterprise 802.11 Device Server family provide an industry-leading solution with breakthrough performance and security for M2M applications and drop in replacements for existing 802.11b and 802.11g networking modules.

### KEY FEATURES

- 802.11b/g WiFi Radio with 32bit ARM9 CPU
- Enterprise Class wireless security (WPA2-Enterprise, WPA2-PSK, WPA-PSK, WEP, EAP) with Certificates
- Extended Operating Temperature Range (-40°C to +85°C) and environmental specifications
- Fully integrated serial bridge and network stack
- Available UART, Ethernet, SPI and RS232/422/485 interfaces
- Integrated 10/100 Ethernet PHY
- Configurable wireless and wired interfaces
- Removes need for RF, networking and communications expertise
- Quick time to market and reduced integration costs
- FCC Part 15 Class B Sub C Modular Approval minimizes regulatory requirements
- Upgradable Airborne Device Server Firmware
- 5 year limited warranty

### Model Selection Guide

Model #	Description	WiFi		Interface					Security			
		802.11b/g	UART	RS232	RS422/485	SPI	Ethernet	GPIO	WEP	WPA	WPA2	EAP
WLANG-SE-DP501	802.11b/g, UART with RS-232/422/485 driver control	■	■	■	■			■	■	■	■	■
WLANG-SP-DP501	802.11b/g, SPI interface	■				■		■	■	■	■	■
WLANG-AN-DP501	UART interface	■	■	■	■			■	■	■	■	■
WLANG-ET-DP501	802.11b/g, 10/100 Ethernet interface	■					■	■	■	■	■	■
<i>To evaluate all available features and receive evaluation tools, order below.</i>												
WLANG-EK-DP501 <sup>1</sup>	802.11b/g Enterprise Class Device Server Module Eval Kit											

<sup>1</sup>Evaluation kit supports all models of the WLANG-XX-DP500 series

# Block Diagram

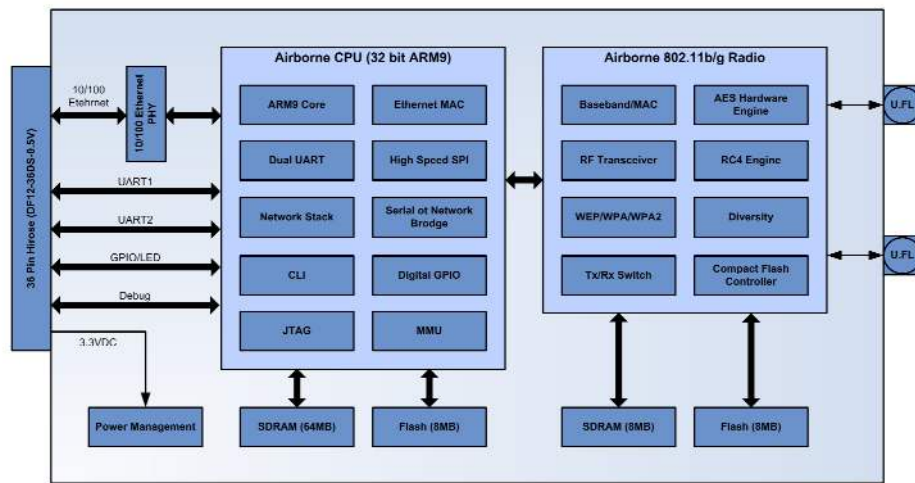

# Mechanical Outline

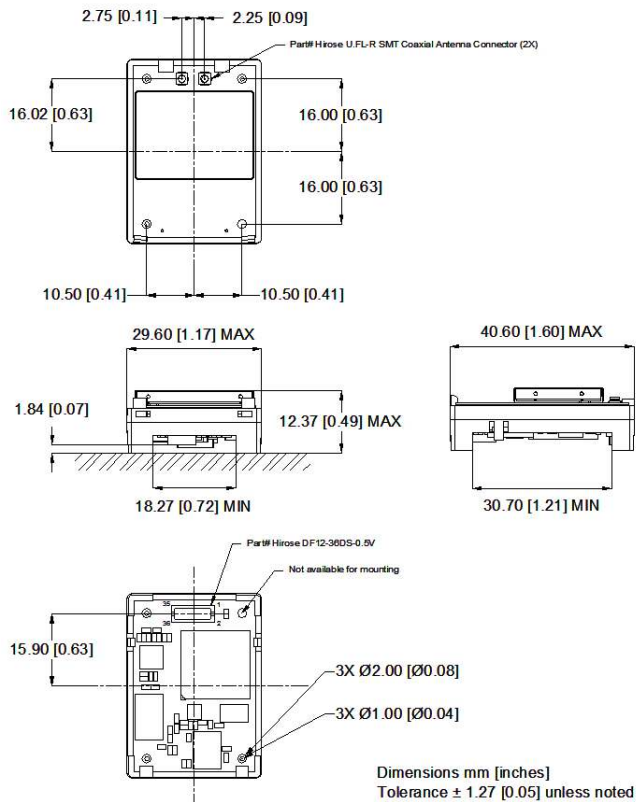

# Specifications

Technology	IEEE 802.11b/g, WiFi compliant
Frequency	2.4 ~ 2.4835 GHz (US/Canada/Europe) 2.4 ~ 2.497 GHz (Japan)
Modulation Technology	DSSS, CCK, OFDM
Modulation Type	DBPSK, DQPSK, CCK, BPSK, QPSK, 16QAM, 64QAM
Network Access Modes	Infrastructure, Ad Hoc
Channels	USA/Canada: 11 channels Europe: 13 channels France: 4 channels Japan: 14 channels (13 channels for 802.11g)
Wireless Data Rate	802.11b = 11, 5.5, 2, 1 Mbps 802.11g = 54, 48, 36, 24, 18, 12, 9, 6 Mbps
MAC	CSMA/CA with ACK, RTS, CTS
Network Protocols	TCP/IP, ARP, ICMP, DHCP, DNS, UDAP, TFTP, UDP, PING
Receive Sensitivity	54Mb/s = -71dBm 36Mb/s = -77dBm 18Mb/s = -83dBm 11Mb/s = -85dBm 5.5Mb/s = -86dBm 1Mb/s = -87dBm
Security Protocols	Disabled, WEP 64 & 128bit, WPA (TKIP), WPA (AES), WPA2 (AES), 802.1x (EAP) Suppliant Supports WPA & WPA2 Enterprise supplicants (EAP-TLS, EAP-TTLS(MSCHAPv2), EAP-TTLS(MD5), EAP-PEAPv0(MSCHAPv2, LEAP) Supports Certificates
Antenna	Two (2) U.FL coaxial connectors, 50 ohms, supports diversity
Supply	3.3VDC +/-5%, 850mA (MAX)
Supply In-rush Current	3000mA (MAX) for 20ms
DC Characteristics	Operating Current (Tx, 802.11g) = 620mA Typ. Operating Current (Rx, 802.11g) = 420mA Typ. Power Save (Doze) = 10mA Typ. Power Down (Sleep) = 1mA Typ.
Environmental	Operating Temperature: -40°C - +85°C, Storage: -55°C - +150°C Relative humidity: 5% - 95% (non-condensing) Vibration: 20G peak-to-peak, 20Hz-2KHz swept Shock: 1500G peak-to-peak, 0.5mS duration
Interfaces	UART (960KBAUD), RS232, RS422, RS485, SPI (1bit/20MHz), 10/100 Ethernet
Digital I/O	8 GPIO
LED Indicators	4 indicator LED signals (RF_ACT, POST, CONNECT, RF_LINK)
Connector	36 pin High Density SMT connector from Hirose (DF12-36DS-0.5V), 4mm Height
Agency Approvals	North America: FCC Title 47 Part 15 Class B Sub C Intentional Radiator, IOC RSS210 Europe: CE ETSI EN300 328 RoHS & WEEE compliant



5675 Hudson Industrial Parkway Hudson, OH 44236