

SPEC Pak®

5 Pole Mid Power

- IP68 • Compact Sealed Connector • 3 Phase AC Power Distribution
- Motors & Controls • Industrial Equipment • 60 Amps



SPECIFICATIONS

Mechanical

Environmental Seal

IEC 60529	IP 68
UL 50E	UL Approved

Wire Size	10 to 8 AWG	6.0 to 8.4 mm ²
------------------	-------------	----------------------------

Operating Temperature

UL 1977	-40 to 105°C	-40 to 221°F
---------	--------------	--------------

Mating Cycles (no load)	250 min
--------------------------------	---------

Mating Force (nominal)	28 lbf	125 N
-------------------------------	--------	-------

Unmating Force	12 lbf	53 N
-----------------------	--------	------

Contact Retention Force (min)	50 lbf	222 N
--------------------------------------	--------	-------

Touch Safe (IEC 60529)	IP 20 (female socket side only)
-------------------------------	---------------------------------

Enclosure Ratings	UL 50 E 4 x 4 *
--------------------------	-----------------

* Need stainless hardware- type 304 or 316

Electrical

Current Rating (Amperes)	UL 1977	CSA
10 AWG	45A	30A
8 AWG	60A	40A

Voltage Rating

UL 1977 (AC/DC)	600
-----------------	-----

Grounding

UL 2238, Sec 37.8	Impedance
-------------------	-----------

Contact Resistance (average)	.300 Milliohms
-------------------------------------	----------------



File No. E26226

Materials

Shell, Housing & Sealing Nut	PC / PBT
---	----------

Lanyard	Nylon / Polyester
----------------	-------------------

Contact Holders	PBT- GF
------------------------	---------

Contact Retention Clip	Be-Cu
-------------------------------	-------

Latch	Stainless Steel
--------------	-----------------

Panel Gasket	NBR
---------------------	-----

Sealing Gland	EPDM
----------------------	------

Flammability	UL94 V-0
---------------------	----------

Glowwire	960°C (GWFI)
-----------------	--------------

	825°F (GWIT)
--	--------------

Weatherability	UL 746C F1
-----------------------	------------

Sockets	Copper
----------------	--------

SC08-GH	Ag plating over Ni
---------	--------------------

SC08-SN	Ag plating over Ni
---------	--------------------

Pins	Copper
-------------	--------

PP08SGH	Ag plating over Ni
---------	--------------------

PC08SSN	Ag plating over Ni
---------	--------------------

Silver = Ag Nickel = Ni

IEC 61984

Attributes

AMP Rating AC	60A
----------------------	-----

Voltage Rating AC	800V AC (operational)
--------------------------	-----------------------

Finger Safety **	IEC 60529
-------------------------	-----------

Protection Degree	IP20 Unmated, IP68 Mated
--------------------------	--------------------------

Wire Size Tested	8 AWG
-------------------------	-------

Contact Series Tested	PC08SSN, PP08SGH SC08-SN, SC08-GH
------------------------------	-----------------------------------

Climatic Testing (Cold, Heat & MFG)	IEC 60512 Test -11j, 11i & 11g
--	--------------------------------

Cycle Life	IEC 60512 Test 9A- 5000 Cycles
-------------------	--------------------------------

Mechanical Strength Impact	IEC 60512 @ 29.5 Inches- dropped 8 times
-----------------------------------	---

Temperature Range	-40 to 105°C, -40 to 221°F
--------------------------	----------------------------

Protection

Touch Safety with Finger Proof Housings & Wire Contacts

IEC 60529	IP20 unmated, IP68 mated
------------------	--------------------------

* In mated and unmated condition, for standard 8 AWG wire contacts (only)

** Female side unmated

IEC 60950-1

Creepage / Clearance per IEC 60950-1	9.55 (mated or unmated)
---	-------------------------

Material Group	IIIa
-----------------------	------

* In mated and unmated condition, for standard 8 AWG wire contacts (only)

** Female side unmated

ORDERING INFORMATION

SPEC Pak® is a highly configurable environmentally sealed connector. For convenience, follow the steps below to determine component part numbers.

Step 1: Select Shell

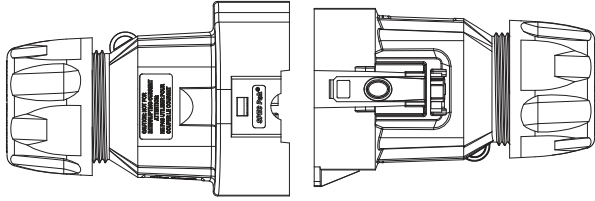

SK1-076D05
Inline Receptacle

SK6-076D05
Plug

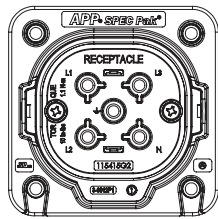

SK2-076D05
Panel Mount Receptacle & Gasket

Description	Part Numbers
Minimum Quantity	25
Inline Receptacle Shell	SK1-076D05
Plug Shell	SK6-076D05
Panel Mount Receptacle	SK2-076D05
Receptacle Cover	SK9-076 (shown on back page)
Plug Cover	SK9P-076 (shown on back page)

- Contact holders are available with multiple keys, please inquire.

Step 2: Select Sealing Gland

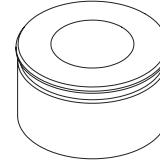

* Define:

	<u>Number of Wires</u>	<u>Wire OD</u>
Wires		
- Discrete	_____	_____
- Bundled	_____	_____

* Select wire protection that will accommodate the number of wires and outer diameter (OD) of the wire used in your application.

* Wire protection is required for use with inline receptacles (SK1-076D05) and plugs (SK6-076D05) to obtain IP68 seal.

Number of Holes	Cable Range Wire Outer Diameter mm (in)	Sealing Grommet Part Number Only
Minimum Quantity		10
1	20.0 mm- 24.0 mm (0.79" - 0.85")	B02130P7

* For other wire configurations contact manufacturer

Torque Requirements

Hand tighten. Using a 44 mm wrench or strap wrench, tighten an additional 3/4—1 turn (approximately 7.9 Nm (70 in- lb)).

Step 3: Select Contacts

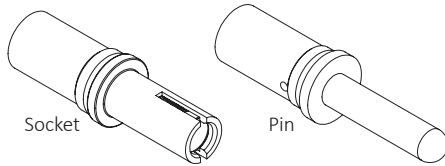

* Define:

	<u>Number of Circuits</u>	<u>Wire Gauge</u>
Contacts	_____	_____
- Power	_____	_____
- Other	_____	_____

Amps (continuous): _____ Max amps at _____ Volts

* Select power and/or ground contacts appropriate for your wire size (AWG or mm²).

- Sockets are used in the receptacles (part numbers SK1-076D05 & SK2-076D05)
- Pins are used in the plug (part number SK6-076D05)
- Solid wires not recommended

TEMPERATURE CHART

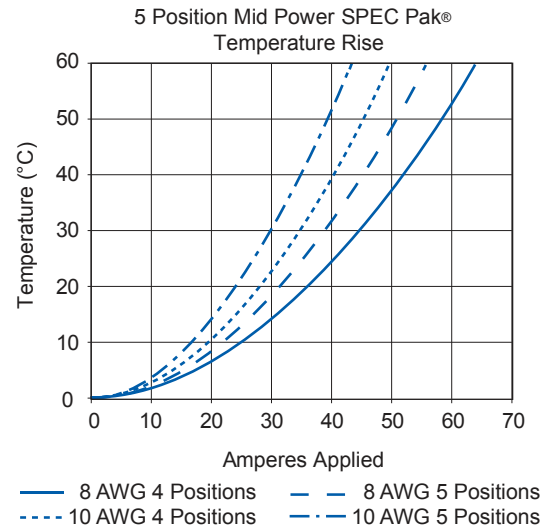

Description	Part Numbers
Minimum Quantity	10
Power Drawer® #8 socket crimp, hot plug/ground	SC08-GH
Power Drawer® #8 socket crimp, standard mate	SC08-SN
Power Drawer® #8 pin crimp, hot plug/ground	PP08SGH
Power Drawer® #8 pin crimp, standard mate	PC08SSN

TOOLING INFORMATION

Wire Size		Part Number	Crimp Tools									
AWG	MM ²	Power Contacts	Description	Pneumatic Bench Tool	+	Die	+	Locator	OR	Daniels Manufacturing Tool		
										Tool	Die	Locator
#8/10	8.4/6.0	SC08-GH	POWER DRAWER CONTACT, #8 SOCKET CRIMP, FIRST MATE GROUND							M22520/23-01	M22520/23-2	M22520/23-9
#8/10	8.4/6.0	SC08-SN	POWER DRAWER CONTACT, #8 SOCKET CRIMP, STANDARD MATE	1387G1		1388G6		1389G19		M22520/23-01	M22520/23-2	M22520/23-9
#8/10	8.4/6.0	PP08SGH	POWER DRAWER CONTACT, #8 PIN, CRIMP, STANDARD MATE, FIRST MATE GROUND							M22520/23-01	M22520/23-2	M22520/23-9
#8/10	8.4/6.0	PC08SSN	POWER DRAWER CONTACT, 8.4/6.0 #8, PIN, CRIMP, STANDARD MATE							M22520/23-01	M22520/23-2	M22520/23-9
#8/10	8.4/6.0	M81969/14-06	INSERT AND EXTRACT TOOL									

* Must contact Daniels directly for this tooling option, www.dmctools.com



Pneumatic Bench Tool - **1387G1**

Locator - **1389G19**



Die - **1388G6**



Insert & Extract Tool - **M81969/14-06**

Dimensions

Plug Mid Power | SK6-076D05

Front View

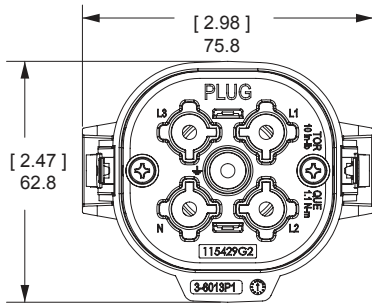

Side View

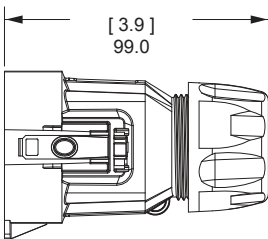

Mated View

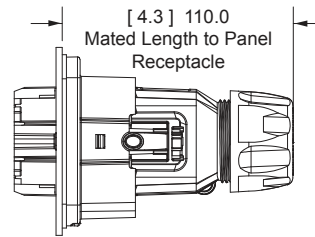

Panel Mount Receptacle Mid-Power | SK2-076D05

Panel Cut Out

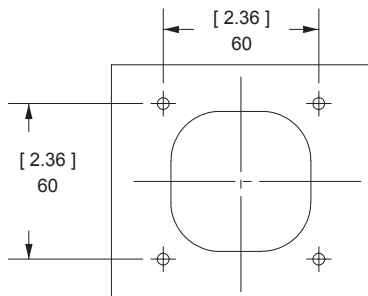

Front View

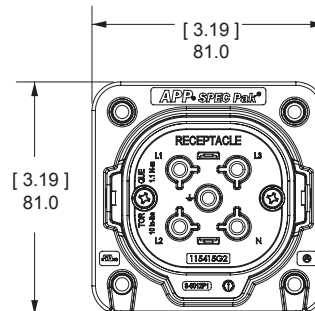

Side View

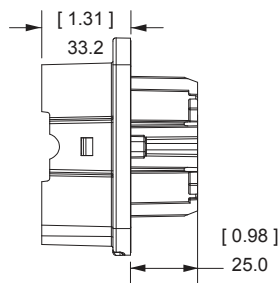

Mated View

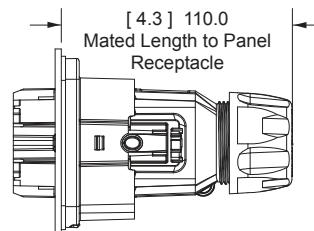

Inline Receptacle Mid-Power | SK1-076D05

Front View

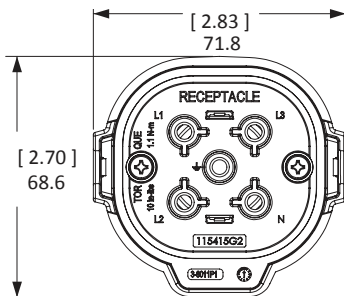

Side View

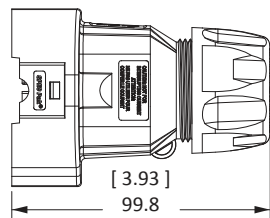

Mated View

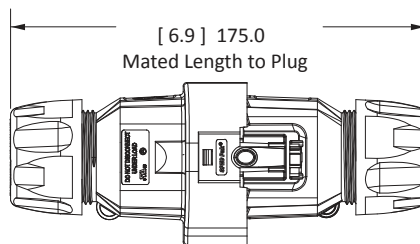

Plug Cover Kit | SK9P-076

Front View

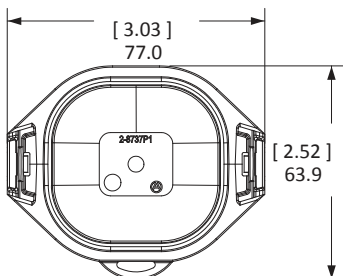

Side View



Receptacle Cover Kit | SK9-076

Front View

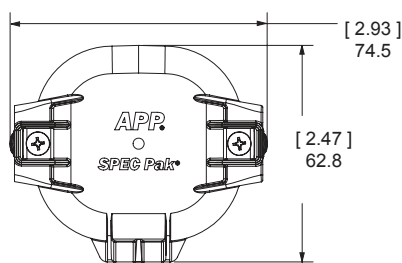

Side View

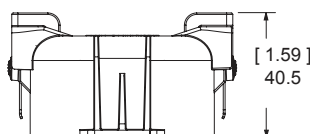

All Data Subject To Change Without Notice 2019-0161 DS-MPSPAK5P REV 2

Anderson will use reasonable efforts to include accurate and up-to-date content in the data sheet. All product information contained in the data sheet including ordering information, illustrations, specifications, and dimensions, are believed to be reliable as of the date of publishing, but is subject to change without notice. Anderson makes no warranty or representation as to its accuracy. Content in the data sheet may contain technical inaccuracies, typographical errors and may be changed or updated without notice. Anderson™ may also make improvements and/or changes to the products and/or to the programs described in the content at any time without notice. Current sales drawings and specifications are available upon request.

© 2019 Anderson Power Products, Inc. All rights reserved. SPEC Pak®, Power Drawer®, APP®, A®, Anderson Power Products® and the APP logo are registered trademarks of Anderson Power Products, Inc.



HEADQUARTERS: Anderson Power Products®, 13 Pratts Junction Road, Sterling, MA 01564-2305 USA T:978-422-3600 F:978-422-0128 • **EUROPE:** Anderson Power Products® Ltd., Unit 3, Europa Court, Europa Boulevard, Westbrook, Warrington, Cheshire, WA5 7TN United Kingdom T: +44 (0) 1925 428390 F: +44 (0) 1925 520203 • **ASIA / PACIFIC:** IDEAL Anderson Asia Pacific Ltd., Unit 922-928 Topsail Plaza, 11 On Sum Street, Shatin N.T., Hong Kong T: +(852) 2636 0836 F: +(852) 2635 9036 • **CHINA:** IDEAL Anderson Technologies (Shenzhen) Ltd., Block A8 Tantou Western Industrial Park, Songgang Baoan District, Shenzhen, PR. China 518105 T: +(86) 755 2768 2118 F: +(86) 755 2768 2218 • **TAIWAN:** IDEAL Anderson Asia Pacific Ltd., Taiwan Branch, 4F.-2, No.116, Dadun 20th St., Situn District, Taichung City 407, Taiwan (R.O.C.) T: +(886) 4 2310 6451 F: +(886) 4 2310 6460 • www.andersonpower.com