



ON Semiconductor®

<http://onsemi.com>

LB1947VC

Monolithic Digital IC PWM Current Control Type Forward/Reverse Motor Driver

Overview

The LB1947VC is a PWM current control type forward/reverse motor driver IC. The IC is optimal for use in driving brushed DC motors for printers.

Features

- PWM current control (fixed OFF time)
- Selectable current decay pattern (FAST, SLOW, and MIX DECAY modes)
- Simultaneous ON prevention function (feed-through current prevention)
- Built-in thermal shutdown circuit
- Built-in noise canceler

Specifications

Absolute Maximum Ratings at $T_a = 25^\circ\text{C}$

Parameter	Symbol	Conditions	Ratings	Unit
Maximum motor supply voltage	V_{BB} max		50	V
Output peak current	I_O peak	$t_w \leq 20\mu\text{s}$	2.25	A
Output continuous current	I_O max		2.0	A
Logic supply voltage	V_{CC} max		7.0	V
Logic input voltage range	V_{IN}		-0.3 to V_{CC}	V
Emitter output voltage	V_E max		1.1	V
Reference voltage	V_{REF}		-0.3 to V_{CC}	V
Allowable power dissipation	P_d max	Independent IC	1.3	W
Operating temperature	T_{opr}		-20 to +85	$^\circ\text{C}$
Storage temperature	T_{stg}		-55 to +150	$^\circ\text{C}$

Caution 1) Absolute maximum ratings represent the value which cannot be exceeded for any length of time.

Caution 2) Even when the device is used within the range of absolute maximum ratings, as a result of continuous usage under high temperature, high current, high voltage, or drastic temperature change, the reliability of the IC may be degraded. Please contact us for the further details.

Stresses exceeding Maximum Ratings may damage the device. Maximum Ratings are stress ratings only. Functional operation above the Recommended Operating Conditions is not implied. Extended exposure to stresses above the Recommended Operating Conditions may affect device reliability.

LB1947VC

Allowable Operating Ranges at $T_a = 25^\circ\text{C}$

Parameter	Symbol	Conditions	Ratings	Unit
Motor supply voltage	V_{BB}		10 to 45	V
Logic supply voltage	V_{CC}		4.75 to 5.25	V
Reference voltage	V_{REF}		0 to $V_{CC}-2$	V

Electrical Characteristics at $T_a = 25^\circ\text{C}$, $V_{CC} = 5\text{V}$

Parameter	Symbol	Conditions	Ratings			Unit
			min	typ	max	
Output Block						
Output stage supply current	$I_{BB\ ON}$	No-load state, Forward	0.4	0.6	1.0	mA
	$I_{BB\ BR}$	No-load state, Brake	0.2	0.4	0.8	mA
	$I_{BB\ OFF}$	No-load state, Output off	0.2	0.4	0.8	mA
	$I_{BB\ wt}$	No-load state, Standby mode			0.1	mA
Output saturation voltage	V_{Osat1}	$I_O = +1.0\text{A}$, Sink		1.2	1.5	V
	V_{Osat2}	$I_O = +2.0\text{A}$, Sink		1.6	1.9	V
	V_{Osat3}	$I_O = -1.0\text{A}$, Source		1.8	2.2	V
	V_{Osat4}	$I_O = -2.0\text{A}$, Source		2.1	2.4	V
Output leak current	$I_{O1(Leak)}$	$V_O = V_{BB}$, Sink			50	μA
	$I_{O2(Leak)}$	$V_O = 0\text{V}$, Source	-50			μA
Output sustain voltage	V_{SUS}	$L = 3.9\text{mH}$, $I_O = 2.0\text{A}$, Design guarantee value*	50			V
Logic Block						
Logic supply current	$I_{CC\ ON}$	IN1: High, IN2: Low, ST: High	11	16	21	mA
	$I_{CC\ BR}$	IN1: Low, IN2: High, ST: High	11	16	21	mA
	$I_{CC\ OFF}$	IN1: Low, IN2: Low, ST: High	11	16	21	mA
	$I_{CC\ wt}$	ST: Low	1.0	2	3.0	mA
Logic pin input voltage (ST, IN1, IN2, VI)	V_{INH}	High level voltage	2			V
	V_{INL}	Low level voltage			0.8	V
Logic pin input current (ST, IN1, IN2, VI)	I_{INH}	$V_{IN} = 5\text{V}$	60	90	120	μA
	I_{INL}	$V_{IN} = 0.8\text{V}$	6	10	13	μA
Sensing voltage	V_E		0		1.1	V
Sensing voltage 25H	V_{EH25}	VI = High, $V_{REF} = 2.5\text{V}$	0.970	1.0	1.030	V
Sensing voltage 25L	V_{EL25}	VI = Low, $V_{REF} = 2.5\text{V}$	0.483	0.5	0.513	V
Sensing voltage 15H	V_{EH15}	VI = High, $V_{REF} = 1.5\text{V}$	0.385	0.4	0.410	V
Sensing voltage 15L	V_{EL15}	VI = Low, $V_{REF} = 1.5\text{V}$	0.190	0.2	0.210	V
Sensing voltage 05H	V_{EH05}	VI = High, $V_{REF} = 0.5\text{V}$	0.190	0.2	0.210	V
Sensing voltage 05L	V_{EL05}	VI = Low, $V_{REF} = 0.5\text{V}$	0.092	0.1	0.108	V
Reference current	I_{ref}	$V_{REF} = 1.0\text{V}$	-0.5		+0.5	μA
CR pin current	I_{CR}	CR = 1.0V	-1.56	-1.3	-1.04	mA
MD pin input voltage	V_{MDH}	High level voltage	$V_{CC}-0.3$			V
	V_{MDM}	Middle level voltage	$0.3V_{CC}$		$V_{CC}-1.0$	V
	V_{MDL}	Low level voltage			.04	V
MD pin input current	I_{MDH}	MD = $V_{CC}-0.5\text{V}$, CR = 1.0V	-1.0		+1.0	μA
	I_{MDL}	MD = 0.4V, CR = 2.0V	-5.0			μA
Thermal shutdown temperature	TSD	Design guarantee value*		170		$^\circ\text{C}$

* Design guarantee value, Do not measurement.

LB1947VC

Package Dimensions

unit : mm (typ)

3336

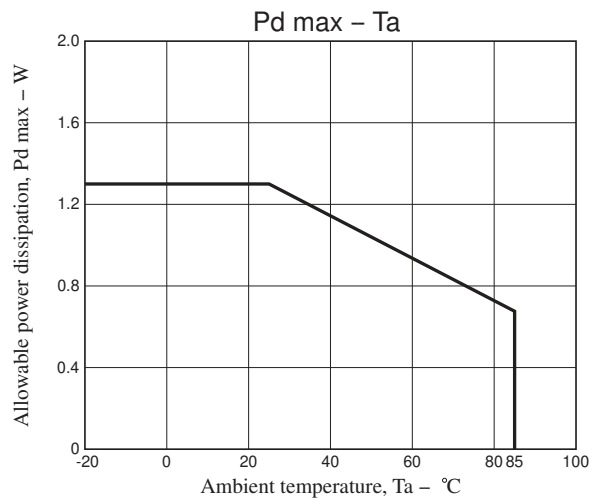
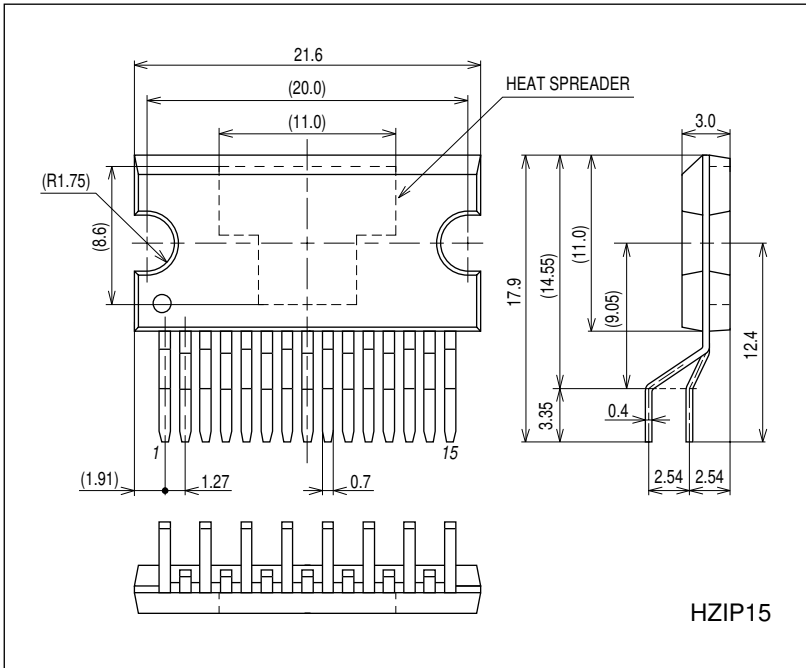

Pin Assignment

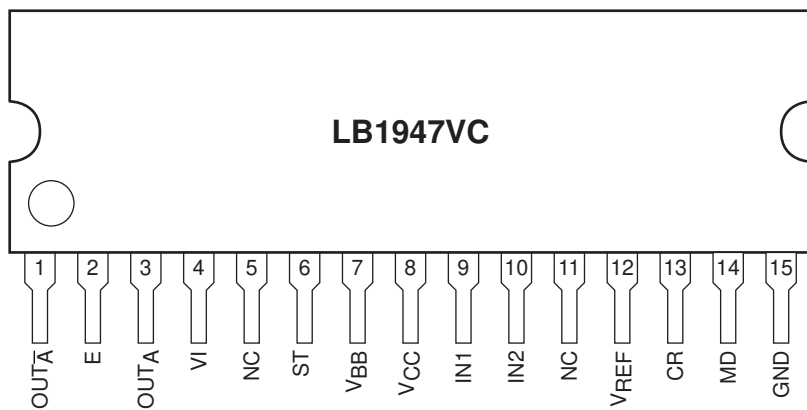

Top view

LB1947VC

Block Diagram

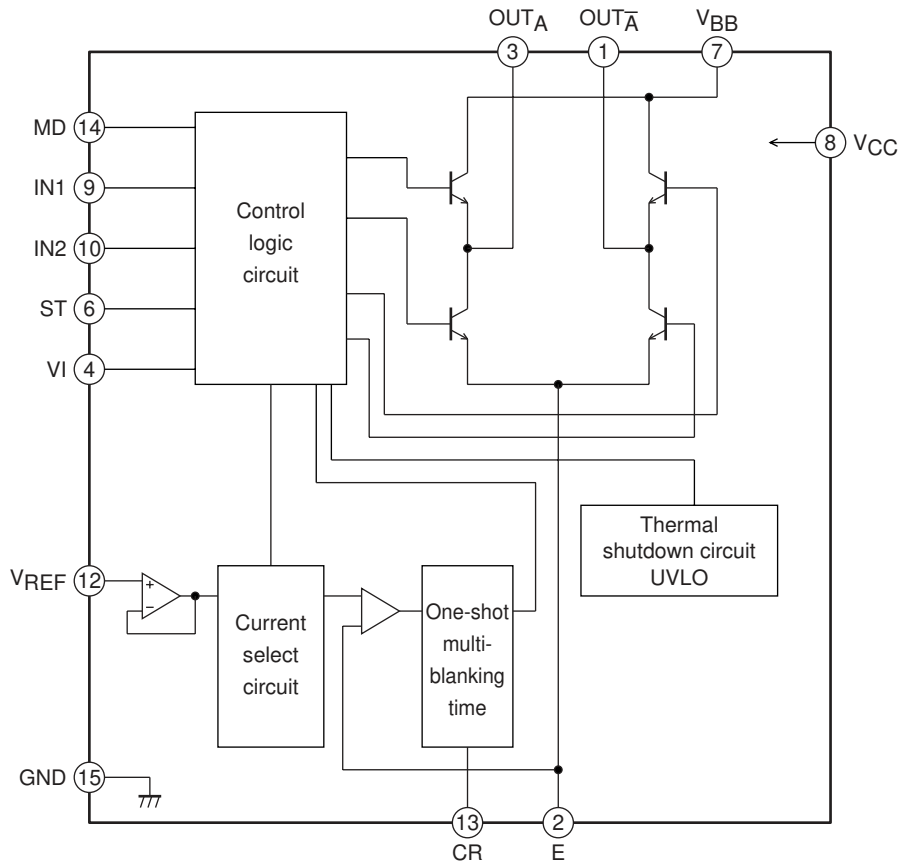

Truth Table

IN1	IN2	ST	VI	MD	OUT _A	OUT _A [̄]	Operating mode
H	L	H	H	L	H	L	Forward, 2/5 times, FAST
H	L	H	H	M	H	L	Forward, 2/5 times, MIX
H	L	H	H	H	H	L	Forward, 2/5 times, SLOW
H	L	H	L	L	H	L	Forward, 1/5 times, FAST
H	L	H	L	M	H	L	Forward, 1/5 times, MIX
H	L	H	L	H	H	L	Forward, 1/5 times, SLOW
H	H	H	H	L	L	H	Reverse, 2/5 times, FAST
H	H	H	H	M	L	H	Reverse, 2/5 times, MIX
H	H	H	H	H	L	H	Reverse, 2/5 times, SLOW
H	H	H	L	L	L	H	Reverse, 1/5 times, FAST
H	H	H	L	M	L	H	Reverse, 1/5 times, MIX
H	H	H	L	H	L	H	Reverse, 1/5 times, SLOW
L	H	H	H	L	L	L	Brake, 2/5 times, FAST
L	H	H	H	M	L	L	Brake, 2/5 times, MIX
L	H	H	L	L	L	L	Brake, 1/5 times, FAST
L	H	H	L	M	L	L	Brake, 1/5 times, MIX
L	H	H	X	H	L	L	Brake, no current limiting
L	L	H	X	X	OFF	OFF	Output OFF
X	X	L or OPEN	X	X	OFF	OFF	Standby mode (circuit OFF)

Except for MD pin, Low at input OPEN.

MD M: determined by external voltage.

LB1947VC

Pin Function

Pin No.	Pin name	Function	Equivalent circuit
1 3	OUT _A OUT _A	Output pin.	
2	E	Sense voltage control pin.	
4	VI	High: sense voltage is 2/5 of V _{REF} Low: sense voltage is 1/5 of V _{REF}	
6	ST	High: circuit operation ON Low: standby mode	
9	IN1	High: rotation mode Low: brake mode	
10	IN2	High: reverse mode Low: forward mode	
7	V _{BB}	Motor power supply voltage.	
8	V _{CC}	Logic power supply voltage.	
12	V _{REF}	Output current setting reference pin. Setting range: 0 to (V _{CC} -2V)	
13	CR	Oscillator with self-excitation.	
14	MD	Current attenuation switching pin. Low : FAST DECAY High: SLOW DECAY M : MIX DECAY M is set by external power supply voltage. Range : 1.1 to 4.0V	
15	GND	Ground pin	
5, 11	NC	No connect	

LB1947VC

Sample Application Circuits

1. Forward/reverse motor with current limiter

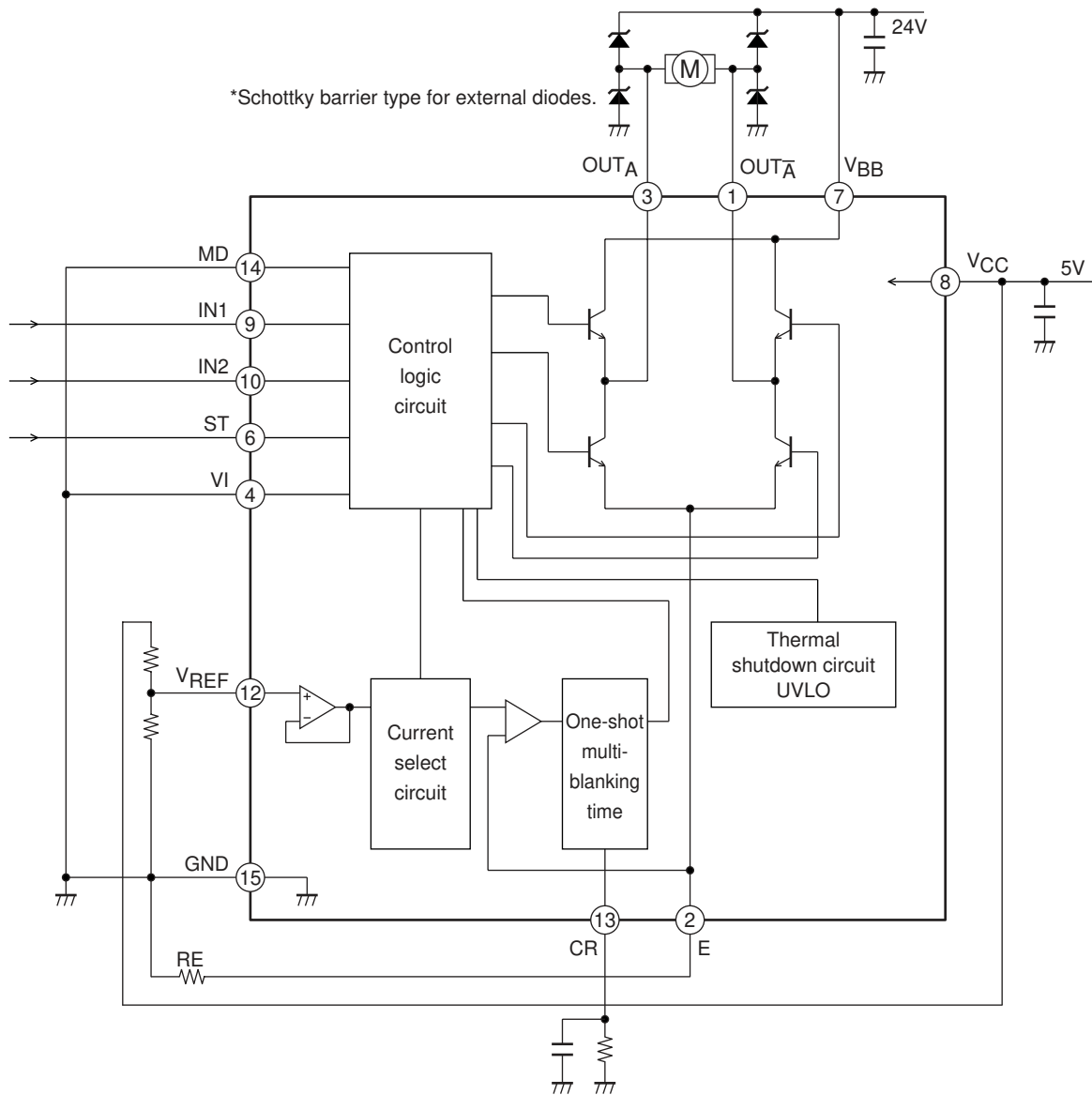

Limiter current setting method

$$I = V_{REF} / (5 \times RE)$$

IN1	IN2	ST	OUT _A	OUT _A [̄]	Mode
H	L	H	H	L	Forward
H	H	H	L	H	Reverse
L	H	H	L	L	Brake
L	L	H	OFF	OFF	Output OFF
-	-	L	OFF	OFF	Standby mode

LB1947VC

2. Forward/reverse motor

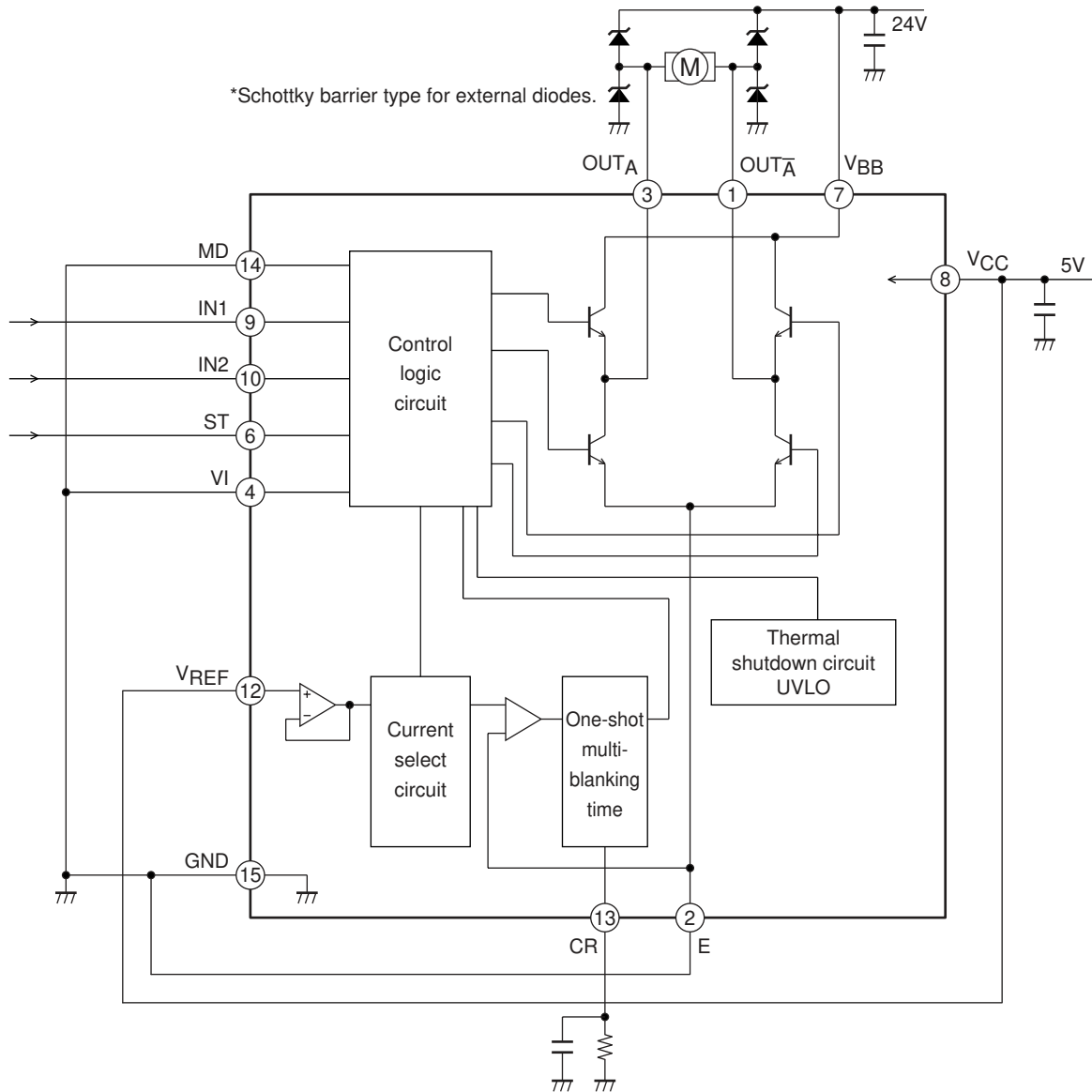

IN1	IN2	ST	OUT _A	OUT _A [̄]	Mode
H	L	H	H	L	Forward
H	H	H	L	H	Reverse
L	H	H	L	L	Brake
L	L	H	OFF	OFF	Output OFF
-	-	L	OFF	OFF	Standby mode

LB1947VC

3. PWM current control forward/reverse motor (MIX DECAy)

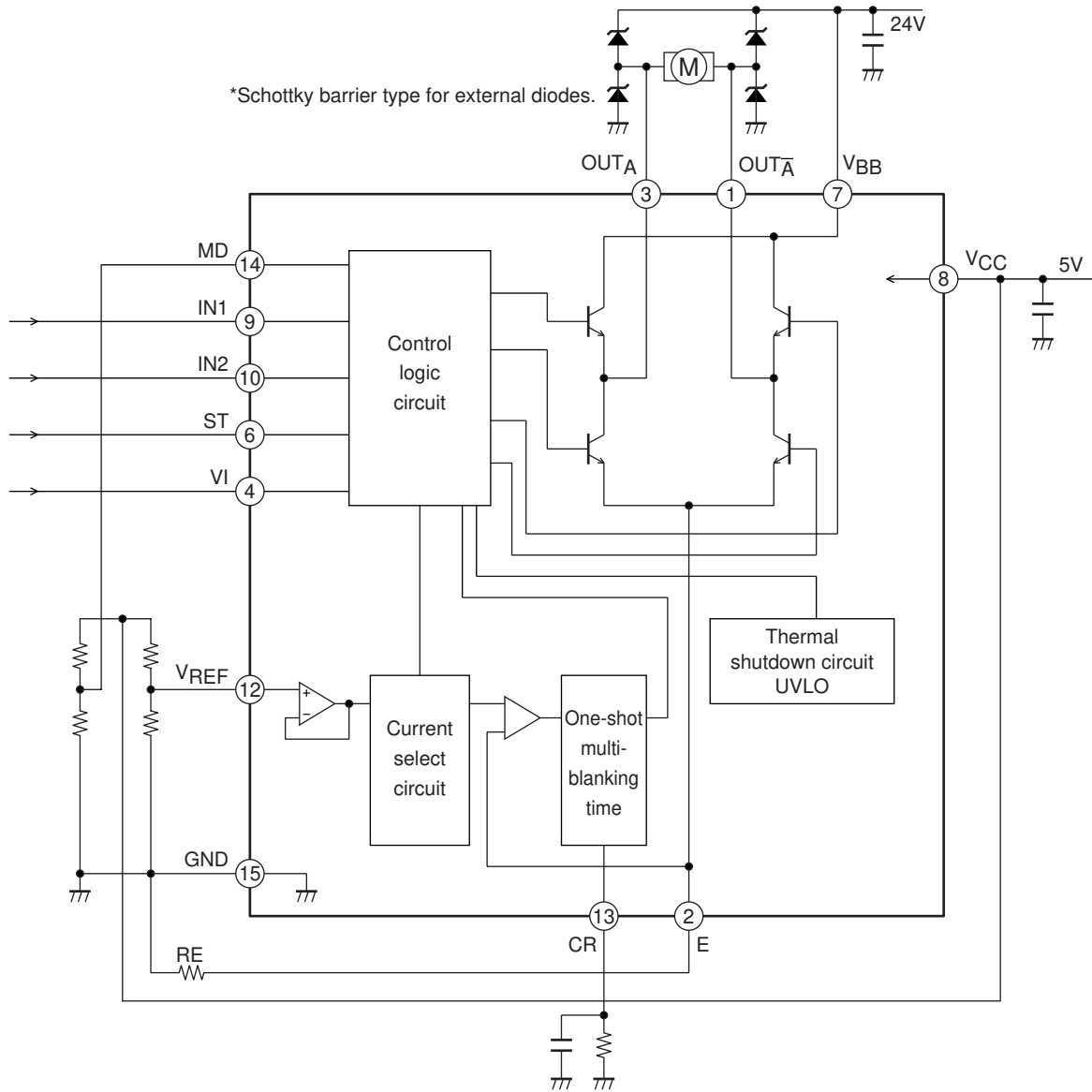

Notes on Usage

1. VREF pin

Because the VREF pin serves for input of the set current reference voltage, precautions against noise must be taken.

2. GND pin

The ground circuit for this IC must be designed so as to allow for high-current switching. Blocks where high current flows must use low-impedance patterns and must be removed from small-signal lines. Especially the ground connection for the sensing resistor RE at pin E, and the ground connection for the Schottky barrier diodes should be in close proximity to the IC ground.

The capacitors between VCC and ground, and VBB and ground should be placed close to the VCC and VBB pins, respectively.

3. CR pin setting (Switching off time, Noise cancel time)

The noise cancel time (Tn) and the switching off time (Toff) are set by the following expressions:

$$\text{Noise cancel time: } T_n \approx C \times R \times \ln \left\{ \frac{(1.0 - RI)}{(4.0 - RI)} \right\} [\text{sec}]$$

CR charge current: 1.3mA

$$\text{Switching off time: } T_{\text{off}} \approx -C \times R \times \ln (1.0 / 4.8) [\text{sec}]$$

Internal configuration at CR pin

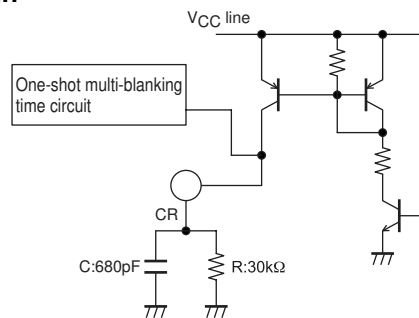

CR constant range: R = 4.7k to 100kΩ

C = 330pF to 2200pF

Heat sink attachment

Heat sinks are used to lower the semiconductor device junction temperature by leading the heat generated by the device to the outer environment and dissipating that heat.

- a. Unless otherwise specified, for power ICs with tabs and power ICs with attached heat sinks, solder must not be applied to the heat sink or tabs.

b. Heat sink attachment

- Use flat-head screws to attach heat sinks.
- Use also washer to protect the package.
- Use tightening torques in the ranges 39-59Ncm(4-6kgcm) .
- If tapping screws are used, do not use screws with a diameter larger than the holes in the semiconductor device itself.
- Do not make gap, dust, or other contaminants to get between the semiconductor device and the tab or heat sink.
- Take care a position of via hole .
- Do not allow dirt, dust, or other contaminants to get between the semiconductor device and the tab or heat sink.
- Verify that there are no press burrs or screw-hole burrs on the heat sink.
- Warping in heat sinks and printed circuit boards must be no more than 0.05 mm between screw holes, for either concave or convex warping.
- Twisting must be limited to under 0.05 mm.
- Heat sink and semiconductor device are mounted in parallel.
Take care of electric or compressed air drivers
- The speed of these torque wrenches should never exceed 700 rpm, and should typically be about 400 rpm.

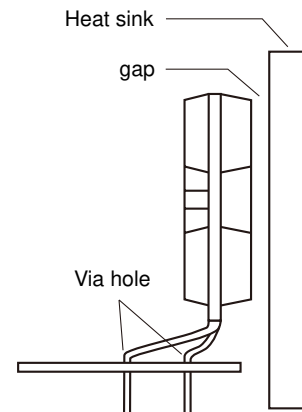
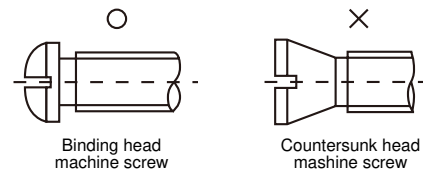

c. Silicone grease

- Spread the silicone grease evenly when mounting heat sinks.
- Our recommends YG-6260 (Momentive Performance Materials Japan LLC)

d. Mount

- First mount the heat sink on the semiconductor device, and then mount that assembly on the printed circuit board.
- When attaching a heat sink after mounting a semiconductor device into the printed circuit board, when tightening up a heat sink with the screw, the mechanical stress which is impossible to the semiconductor device and the pin doesn't hang.

e. When mounting the semiconductor device to the heat sink using jigs, etc.,

- Take care not to allow the device to ride onto the jig or positioning dowel.
- Design the jig so that no unreasonable mechanical stress is not applied to the semiconductor device.

f. Heat sink screw holes

- Be sure that chamfering and shear drop of heat sinks must not be larger than the diameter of screw head used.
- When using nuts, do not make the heat sink hole diameters larger than the diameter of the head of the screws used. A hole diameter about 15% larger than the diameter of the screw is desirable.
- When tap screws are used, be sure that the diameter of the holes in the heat sink are not too small. A diameter about 15% smaller than the diameter of the screw is desirable.

- g. There is a method to mount the semiconductor device to the heat sink by using a spring band. But this method is not recommended because of possible displacement due to fluctuation of the spring force with time or vibration.

ON Semiconductor and the ON logo are registered trademarks of Semiconductor Components Industries, LLC (SCILLC). SCILLC owns the rights to a number of patents, trademarks, copyrights, trade secrets, and other intellectual property. A listing of SCILLC's product/patent coverage may be accessed at www.onsemi.com/site/pdf/Patent-Marking.pdf. SCILLC reserves the right to make changes without further notice to any products herein. SCILLC makes no warranty, representation or guarantee regarding the suitability of its products for any particular purpose, nor does SCILLC assume any liability arising out of the application or use of any product or circuit, and specifically disclaims any and all liability, including without limitation special, consequential or incidental damages. "Typical" parameters which may be provided in SCILLC data sheets and/or specifications can and do vary in different applications and actual performance may vary over time. All operating parameters, including "Typicals" must be validated for each customer application by customer's technical experts. SCILLC does not convey any license under its patent rights nor the rights of others. SCILLC products are not designed, intended, or authorized for use as components in systems intended for surgical implant into the body, or other applications intended to support or sustain life, or for any other application in which the failure of the SCILLC product could create a situation where personal injury or death may occur. Should Buyer purchase or use SCILLC products for any such unintended or unauthorized application, Buyer shall indemnify and hold SCILLC and its officers, employees, subsidiaries, affiliates, and distributors harmless against all claims, costs, damages, and expenses, and reasonable attorney fees arising out of, directly or indirectly, any claim of personal injury or death associated with such unintended or unauthorized use, even if such claim alleges that SCILLC was negligent regarding the design or manufacture of the part. SCILLC is an Equal Opportunity/Affirmative Action Employer. This literature is subject to all applicable copyright laws and is not for resale in any manner.