

FEATURES:

- One high precision N and SSC programmable PLL for CPU
- One high precision N and SSC programmable PLL for SRC[2:1]
- One high precision N and SSC programmable PLL for SRC[7:3] SRC0 (PCI Express) and PCI
- One high precision PLL for 48MHz
- Band-gap circuit for differential outputs
- Support multiple spread spectrum modulation, down and center
- Support SMBus block read/write, index read/write
- Selectable output strength for REF, PCI, 48MHz
- Available in TSSOP package

KEY SPECIFICATION:

- CPU CLK cycle to cycle jitter < 85ps
- SRC CLK cycle to cycle jitter < 125ps

DESCRIPTION:

IDTCV136 is a 56 pin clock device for Intel P4 processors. The CPU output buffer is designed to support up to 400MHz processor. This device also implements Band-gap referenced I_{REF} to reduce the impact of V_{DD} variation on differential outputs, which can provide more robust system performance.

Each CPU/SRC clock has its own Spread Spectrum selection, which allows for isolated changes instead of affecting other clock groups.

FUNCTIONAL BLOCK DIAGRAM

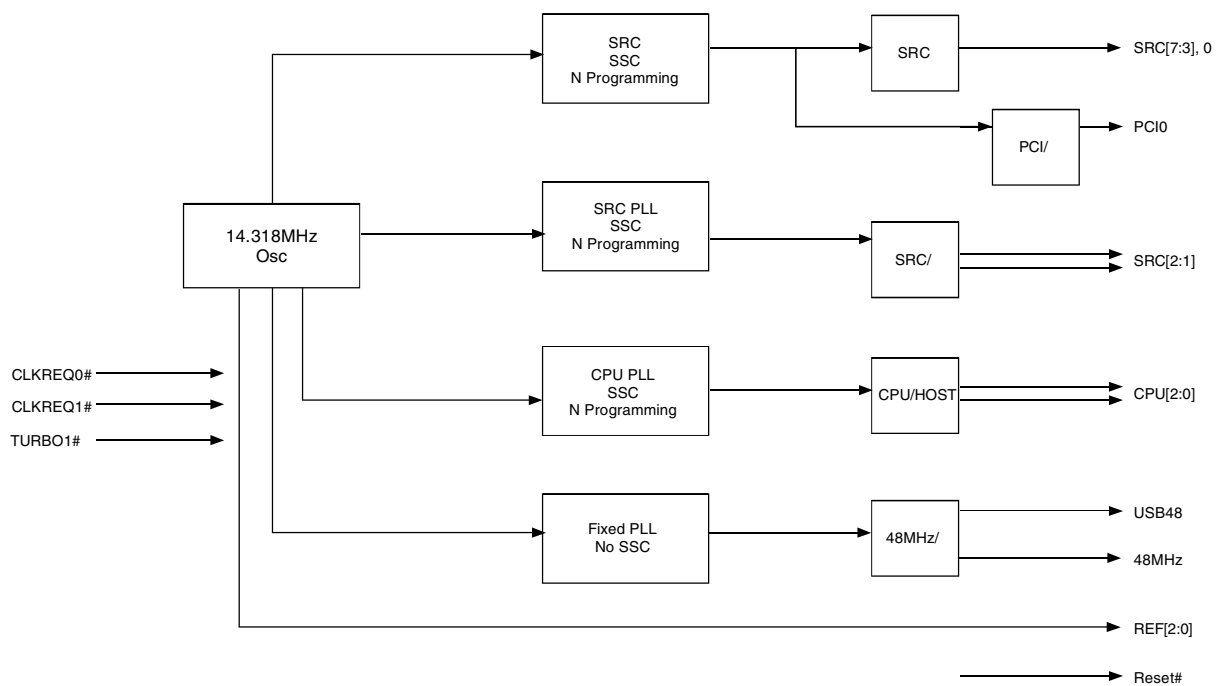

OUTPUT TABLE

CPU	CLKREQ	SRC	PCI	TURBO	USB48	48MHz	REF	RESET#
3	2	8	1	1	1	1	3	1

PIN CONFIGURATION

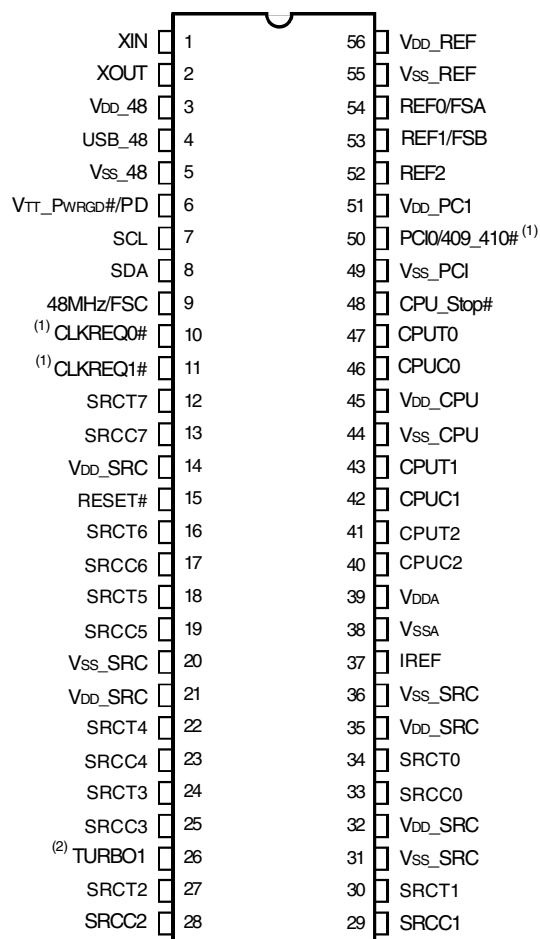

NOTES:

1. Internal 130KΩ pull-down resistor.
2. Power On Tristate.

**SSOP/ TSSOP
TOP VIEW**

FREQUENCY SELECTION

409_410#, FSC, B, A	CPU	SRC
0000	266	100
0001	133	100
0010	200	100
0011	166	100
0100	333	100
0101	100	100
0110	400	100
0111		100
1x00	100	100
1x01	133.3	100
1x10	200	100
1x11	166.67	100
1x00		
1x01		
1x10		
1x11		

CPU AND SRC SPREAD SPECTRUM MAGNITUDE CONTROL

SMC[2:0]	%
000	OFF
001	-0.25
010	-0.5
011	-0.75
100	±0.125
101	±0.25
110	±0.375
111	±0.5

PIN DESCRIPTION

Pin Name	Type	Pin #	Description
XIN	IN	1	XTAL in
XOUT	OUT	2	XTAL out
PCI0/409_410#	I/O	50	PCI clock/ CPU type select, see Frequency Selection Table.
USB48	OUT	4	48MHz
CPUC[2:0] CPUT[2:0]	OUT	40, 41, 42, 43, 46, 47	Differential clock
SRCC[7:0] SRCT[7:0]	OUT	12, 13, 16, 17, 18, 19 22, 23, 24, 25, 27, 28, 29, 30, 33, 34	Differential clock
IREF	OUT	37	Differential output reference current
REF0/FSA	I/O	54	HW frequency select, sampled at V _{TT_PWRGD#} assertion. 14.318MHz afterward.
REF1/FSB	I/O	53	HW frequency select, sampled on V _{TT_PWRGD#} assertion. 14.318MHz afterward.
REF2	OUT	52	14.318MHz
48MHz/ FSC	IN	9	Frequency Select at V _{TT_PWRGD#} assertion. 48 MHz is tri-state at power on.
V _{TT_PWRGD#} /PD	IN	6	3.3V LVTTTL input is a level-sensitive strobe used to latch the FS_A, FS_B, FS_C inputs. After V _{TT_PWRGD#} assertion, becomes a real-time input for asserting power down (active HIGH).
CPU_STP#	IN	48	CPU clock stop, low active
CLKREQ0#	IN	10	SRC OE control, see byte 3 and 4, low active
CLKREQ1#	IN	11	SRC OE control, see byte 3 and 4, low active
SDA	I/O	8	SMBus data
SCL	IN	7	SMBus clock
Turbo1	IN	26	Turbo frequency switch
RESET#	OUT, OD	15	Reset output signal, Open Drain

SE SIGNAL STRENGTH SELECTION

Str[1:0]	Strength
00	0.6x
01	0.8x
10	1x
11	1.2x

PCI (BASED ON SRC = 100MHz)

PCIS[1:0]	PCI
00	33.33
01	36.36
10	40.00
11	30.77

RESOLUTION

Parameter	N Resolution (MHz)	%
CPU = 100MHz mode	0.666667	0.67%
CPU = 133MHz mode	0.666667	0.50%
CPU = 166MHz mode	1.333333	0.80%
CPU = 200MHz mode	1.333333	0.67%
CPU = 266MHz mode	1.333333	0.50%
CPU = 333MHz mode	2.666667	0.80%
CPU = 400MHz mode	2.666667	0.67%
SRC (PCI Express)	0.666667	0.67%

SM PROTOCOL

INDEX BLOCK WRITE PROTOCOL

Bit	# of bits	From	Description
1	1	Master	Start
2-9	8	Master	D2h
10	1	Slave	Ack (Acknowledge)
11-18	8	Master	Register offset byte (starting byte)
19	1	Slave	Ack (Acknowledge)
20-27	8	Master	Byte count, N (0 is not valid)
28	1	Slave	Ack (Acknowledge)
29-36	8	Master	first data byte (Offset data byte)
37	1	Slave	Ack (Acknowledge)
38-45	8	Master	2nd data byte
46	1	Slave	Ack (Acknowledge)
			:
		Master	Nth data byte
		Slave	Acknowledge
		Master	Stop

INDEX BLOCK READ PROTOCOL

Master can stop reading any time by issuing the stop bit without waiting until Nth byte (byte count bit30-37).

Bit	# of bits	From	Description
1	1	Master	Start
2-9	8	Master	D2h
10	1	Slave	Ack (Acknowledge)
11-18	8	Master	Register offset byte (starting byte)
19	1	Slave	Ack (Acknowledge)
20	1	Master	Repeated Start
21-28	8	Master	D3h
29	1	Slave	Ack (Acknowledge)
30-37	8	Slave	Byte count, N (block read back of N bytes).
38	1	Master	Ack (Acknowledge)
39-46	8	Slave	first data byte (Offset data byte)
47	1	Master	Ack (Acknowledge)
48-55	8	Slave	2nd data byte
			Ack (Acknowledge)
			:
		Master	Ack (Acknowledge)
		Slave	Nth data byte
			Not acknowledge
		Master	Stop

RANDOM BYTE WRITE

Setting bit[11]=1, bit[12:18]=starting address, the following is the first write data. After writing it, master issues stop bit.

RANDOM BYTE READ

Setting bit[11]=1, bit[12:18]=starting address, the following is the first read data. After reading back the first data byte, master issues Stop bit.

BYTE 0

Bit	Output(s) Affected	Description/Function	0	1	Type	Power On
7	SRCT7, SRCC7	Output enable	Tristate	Enable	RW	1
6	SRCT6, SRCC6	Output enable	Tristate	Enable	RW	1
5	SRCT5, SRCC5	Output enable	Tristate	Enable	RW	1
4	SRCT4, SRCC4	Output enable	Tristate	Enable	RW	1
3	SRCT3, SRCC3	Output enable	Tristate	Enable	RW	1
2	SRCT2, SRCC2	Output enable	Tristate	Enable	RW	1
1	SRCT1, SRCC1	Output enable	Tristate	Enable	RW	1
0	SRCT0, SRCT0	Output enable	Tristate	Enable	RW	1

BYTE 1

Bit	Output(s) Affected	Description/Function	0	1	Type	Power On
7	USB48	Output Enable	Tristate	Enable	RW	1
6	REF2	Output Enable	Tristate	Enable	RW	1
5	REF1	Output Enable	Tristate	Enable	RW	1
4	REF0	Output Enable	Tristate	Enable	RW	1
3	48MHz	Output Enable	Tristate	Enable	RW	0
2	CPUT2, CPUC2	Output Enable	Tristate	Enable	RW	1
1	CPUT1, CPUC1	Output Enable	Tristate	Enable	RW	1
0	CPUT0, CPUC0	Output Enable	Tristate	Enable	RW	1

BYTE 2

Bit	Output(s) Affected	Description / Function	0	1	Type	Power On
7	PCI0	Output Enable	Tristate	Enable	RW	1
6	Reserved				RW	0
5	PCI SEL1	See PCI select table			RW	0
4	PCI SEL0				RW	0
3	CPUTs	CPUT0 CPU_STOP drive mode	Driven in CPU_STOP#	Tristate when stoped	RW	0
2	CPUT2, CPUC2	Allow control of CPU2 with assertion of CPU_STOP#	Free running, not stopped by CPU_STOP#	Stopped with CPU_STOP#	RW	1
1	CPUT1, CPUC1	Allow control of CPU1 with assertion of CPU_STOP#	Free running, not stopped by CPU_STOP#	Stopped with CPU_STOP#	RW	1
0	CPUT0, CPUC0	Allow control of CPU0 with assertion of CPU_STOP#	Free running, not stopped by CPU_STOP#	Stopped with CPU_STOP#	RW	1

BYTE 3

Bit	Output(s) Affected	Description / Function	0	1	Type	Power On
7	SRC7	Controlled by CLKREQ0# or CLKREQ1#	CLKREQ0#	CLKREQ1#	RW	0
6	SRC6		CLKREQ0#	CLKREQ1#	RW	0
5	SRC5		CLKREQ0#	CLKREQ1#	RW	0
4	SRC4		CLKREQ0#	CLKREQ1#	RW	0
3	SRC3		CLKREQ0#	CLKREQ1#	RW	0
2	Reserved				RW	0
1	Reserved				RW	0
0	SRC0	Controlled by CLKREQB# or CLKREQA#	CLKREQ0#	CLKREQ1#	RW	0

BYTE 4

Bit	Output(s) Affected	Description / Function	0	1	Type	Power On
7	SRC7	When CLKREQ is HIGH, Output is Hi-Z	Not Controlled	Controlled	RW	0
6	SRC6		Not Controlled	Controlled	RW	0
5	SRC5		Not Controlled	Controlled	RW	0
4	SRC4		Not Controlled	Controlled	RW	0
3	SRC3		Not Controlled	Controlled	RW	0
2	Reserved				RW	0
1	Reserved				RW	0
0	SRC0	When CLKREQ is HIGH, Output is Hi-Z	Not Controlled	Controlled	RW	0

BYTE 5

Bit	Output(s) Affected	Description / Function	0	1	Type	Power On
7	SRCs	SRCT Pwrdown drive mode	Driven in power down	Tristate in power down	RW	0
6	CPUs	CPUT0 Pwrdown drive mode	Driven in power down	Tristate in power down	RW	0
5	PCIStrC1	PCI strength selection			RW	1
4	PCIStrC0				RW	0
3	REFStr1	REF strength selection			RW	1
2	REFStr0				RW	0
1	48MHzStr1	USB48MHz strength selection			RW	1
0	48MHzStr0				RW	0

BYTE 6

Bit	Output(s) Affected	Description / Function	0	1	Type	Power On
7	Reserve				RW	0
6	SRC0, SR[7:3], SMC2	SRC0, SRC[7:3] SSC control (see SMC table)			RW	0
5	SRC0, SR[7:3], SMC1				RW	0
4	SRC0, SR[7:3], SMC0				RW	0
3	Reserved				RW	0
2	SRC[2:1], SMC2	SRC[2:1] control (see SMC table)			RW	0
1	SRC[2:1], SMC1				RW	0
0	SRC[2:1], SMC0				RW	0

BYTE 7

Bit	Output(s) Affected	Description / Function	0	1	Type	Power On
7		Revision ID			R	0
6		Revision ID			R	0
5		Revision ID			R	0
4		Revision ID			R	0
3		Vendor ID			R	0
2		Vendor ID			R	1
1		Vendor ID			R	0
0		Vendor ID			R	1

BYTE 8 (INDEX BLOCK READ BYTE COUNT)

Bit	Output(s) Affected	Description / Function	0	1	Type	Power On
7					RW	0
6					RW	0
5					RW	0
4					RW	1
3					RW	0
2					RW	1
1					RW	0
0					RW	0

BYTE 9

Bit	Output(s) Affected	Description / Function	0	1	Type	Power On
7	Reserved				RW	0
6	Reserved				RW	0
5	Reserved				RW	0
4	Reserved				RW	0
3	Reserved				RW	0
2	CPU_SMC2	CPU PLL SSC control (see SMC table)			RW	0
1	CPU_SMC1				RW	0
0	CPU_SMC0				RW	0

BYTE 10

Bit	Output(s) Affected	Description / Function	0	1	Type	Power On
7	WD_1_Timer7	WatchDog_1_Alarm timer Default is 11*290ms			RW	0
6	WD_1_Timer6				RW	0
5	WD_1_Timer5				RW	0
4	WD_1_Timer4				RW	0
3	WD_1_Timer3				RW	1
2	WD_1_Timer2				RW	0
1	WD_1_Timer1				RW	1
0	WD_1_Timer0				RW	1

BYTE 11

Bit	Output(s) Affected	Description / Function	0	1	Type	Power On
7	CPU_N8				RW	0
6	Reserved				RW	0
5	Reserved				RW	0
4	Reserved				RW	0
3	WDRB	Alarm read back, reset by WD disable		Alarm	R	0
2	RESET# ⁽¹⁾	Reset Enable	Disable	Reset Enable	RW	0
1	Reserved				RW	0
0	Watch Dog Enable	Watch Dog Enable	Disable	Enable	RW	0

BYTE 12 (CPU N)

Bit	Output(s) Affected	Description / Function	0	1	Type	Power On
7	CPU_N7	CPU N default should reflect latched FS			RW	1
6	CPU_N6				RW	1
5	CPU_N5				RW	0
4	CPU_N4				RW	0
3	CPU_N3				RW	1
2	CPU_N2				RW	0
1	CPU_N1				RW	0
0	CPU_N0, LSB	CPU CLK = N*Resolution ⁽¹⁾			RW	0

NOTE:

1. Resolution depends on FSA, FSB, and FSC values that are latched during power on (see Resolution table).

BYTE 13 (SRC[2:1] N)

Bit	Output(s) Affected	Description / Function	0	1	Type	Power On
7	SRC1_N7, MSB	SRC2, SRC1			RW	1
6	SRC1_N6				RW	0
5	SRC1_N5				RW	0
4	SRC1_N4				RW	1
3	SRC1_N3				RW	0
2	SRC1_N2				RW	1
1	SRC1_N1				RW	1
0	SRC1_N0, LSB	SRD CLK = N*0.66667			RW	0

BYTE 14 (SRC[7:3], SRC0 N)

Bit	Output(s) Affected	Description / Function	0	1	Type	Power On
7	SRC0_N7, MSB	SRC[7:3], SRC0			RW	1
6	SRC0_N6				RW	0
5	SRC0_N5				RW	0
4	SRC0_N4				RW	1
3	SRC0_N3				RW	0
2	SRC0_N2				RW	1
1	SRC0_N1				RW	1
0	SRC0_N0, LSB	SRD CLK = N*0.66667			RW	0

BYTE 15

Bit	Output(s) Affected	Description / Function	0	1	Type	Power On
7	Reserved		Disable	Enable	RW	0
6	CPU N programming enable		Disable	Enable	RW	0
5	SRC1, SRC2 N Programming enable		Disable	Enable	RW	0
4	SRC0, SRC[7:3] N Programming enable		Disable	Enable	RW	0
3	Turbo1 enable		Disable	Enable	RW	0
2	Turbo1	Turbo Active Selection	Active LOW	Active HIGH	RW	0
1	Reserved				RW	0
0	T1CN8				RW	0

BYTE 16 (TURBO1 N FOR CPU)

Bit	Output(s) Affected	Description / Function	0	1	Type	Power On
7	T1CN7	Turbo1 CPU PLL N setting			RW	1
6	T1CN6				RW	1
5	T1CN5				RW	0
4	T1CN4				RW	0
3	T1CN3				RW	1
2	T1CN2				RW	0
1	T1CN1				RW	0
0	T1CN0				RW	0

BYTE 17 (TURBO1 FOR SRC1,2)

Bit	Output(s) Affected	Description / Function	0	1	Type	Power On
7	TSRC1_N7, MSB	Turbo1 SRC2, SRC1			RW	1
6	TSRC1_N6				RW	0
5	TSRC1_N5				RW	0
4	TSRC1_N4				RW	1
3	TSRC1_N3				RW	0
2	TSRC1_N2				RW	1
1	TSRC1_N1				RW	1
0	TSRC1_N0, LSB	SRC CLK = N*0.66667			RW	0

BYTE 18 (RESERVED FOR USER)

Bit	Output(s) Affected	Description / Function	0	1	Type	Power On
7					RW	0
6					RW	0
5					RW	0
4					RW	0
3					RW	0
2					RW	0
1					RW	0
0					RW	0

BYTE 19 (RESERVED FOR USER)

Bit	Output(s) Affected	Description / Function	0	1	Type	Power On
7					RW	0
6					RW	0
5					RW	0
4					RW	0
3					RW	0
2					RW	0
1					RW	0
0					RW	0

BYTE 20 (RESERVED FOR USER)

Bit	Output(s) Affected	Description / Function	0	1	Type	Power On
7					RW	0
6					RW	0
5					RW	0
4					RW	0
3					RW	0
2					RW	0
1					RW	0
0					RW	0

BYTE 21

Bit	Output(s) Affected	Description / Function	0	1	Type	Power On
7		409_410#			R	409_410#
6		FSC latched value on power up			R	FSC
5		FSB latched value on power up			R	FSB
4		FSA latched value on power up			R	FSA
3	Reserved				RW	0
2	Reserved				RW	0
1	Test_scl	On chip test mode Enable	normal	SCLK=1, CLK outputs=1 SCLK=0, CLK outputs=0	RW	0
0	Test_hiz	CLK Outputs Enable	normal	CLK outputs=Tristate	RW	0

BYTE 62 = 60h

BYTE 63 = 13h

ABSOLUTE MAXIMUM RATINGS⁽¹⁾

Symbol	Description	Min	Max	Unit
V _{DDA}	3.3V Core Supply Voltage		4.6	V
V _{DD}	3.3V I/O Supply Voltage		4.6	V
V _{IH}	3.3V Input HIGH		4.6	V
V _{IL}	3.3V Input LOW	-0.5		V
T _s	Storage Temperature	-65	+150	°C
ESD Prot	Input ESD Protection Human Body Model	2000		V

NOTE:

1. Stresses greater than those listed under ABSOLUTE MAXIMUM RATINGS may cause permanent damage to the device. This is a stress rating only and functional operation of the device at these or any other conditions above those indicated in the operational sections of this specification is not implied. Exposure to absolute maximum rating conditions for extended periods may affect reliability.

ELECTRICAL CHARACTERISTICS - INPUT / SUPPLY / COMMON OUTPUT PARAMETERS

Following Conditions Apply Unless Otherwise Specified:

Operating Condition: TA = 0°C to +70°C, Supply Voltage: VDD = 3.3V ± 5%

Symbol	Parameter	Test Conditions	Min.	Typ.	Max.	Unit
V _{IH}	Input HIGH Voltage	3.3V ± 5%	2	—	V _{DD} + 0.3	V
V _{IL}	Input LOW Voltage	3.3V ± 5%	V _{SS} - 0.3	—	0.8	V
V _{IH_FS}	3.3V Input HIGH Voltage	V _{DD}	0.7	—	V _{DD} + 0.3	V
V _{IL_FS}	3.3V Input LOW Voltage		V _{SS} - 0.3	—	0.35	V
I _{IH}	Input HIGH Current	V _{IN} = V _{DD}	-5	—	5	μA
I _{IL1}	Input LOW Current	V _{IN} = 0V, inputs with no pull-up resistors	-5	—	—	μA
I _{IL2}	Input LOW Current	V _{IN} = 0V, inputs with pull-up resistors	-200	—	—	μA
I _{DD3.3OP}	Operating Supply Current	Full active, C _L = full load	—	—	400	mA
I _{DD3.3PD}	Powerdown Current	All differential pairs driven	—	—	70	mA
		All differential pairs tri-stated	—	—	12	
F _I	Input Frequency ⁽¹⁾	V _{DD} = 3.3V	—	14.31818	—	MHz
L _{PIN}	Pin Inductance ⁽²⁾		—	—	7	nH
C _{IN}	Input Capacitance ⁽²⁾	Logic inputs	—	—	5	pF
C _{OUT}		Output pin capacitance	—	—	6	
C _{INX}		X1 and X2 pins	—	—	5	
	Modulation Frequency ⁽²⁾	Triangular modulation	30	—	33	KHz
	T _{SU_PD#}	Stop response of all clocks after PD# assertion	—	—	100	ns
T _{STAB}	Clock Stabilization ^(2,3)	From V _{DD} power-up or de-assertion of PD# to first clock	—	—	1.8	ms
	T _{RISE_PD#} ⁽²⁾	Rise time of PD#	—	—	5	ns
	T _{FALL_PD#} ⁽²⁾	Fall time of PD#	—	—	5	ns
	T _{SU_CPU} ⁽²⁾	CPU output disable after CPU_Stop# assertion	—	—	60	ns
	T _{DRIVE_CPU_Stop#} ⁽²⁾	CPU output enable after CPU_Stop# de-assertion	—	—	60	ns
	T _{SU_SRC} ⁽²⁾	SRC output disable after CLKREQ# assertion	—	—	60	ns
	T _{DRIVE_SRC} ⁽²⁾	SRC output enable after CLKREQ# de-assertion	—	—	60	ns

NOTES:

1. Input frequency should be measured at the REF output pin and tuned to ideal 14.31818MHz to meet ppm frequency accuracy on PLL outputs.
2. This parameter is guaranteed by design, but not 100% production tested.
3. See TIMING DIAGRAMS for timing requirements.

ELECTRICAL CHARACTERISTICS - CPU AND SRC 0.7 CURRENT MODE DIFFERENTIAL PAIR⁽¹⁾

Following Conditions Apply Unless Otherwise Specified:

Operating Condition: TA = 0°C to +70°C, Supply Voltage: VDD = 3.3V ± 5%; CL = 2pF

Symbol	Parameter	Test Conditions	Min.	Typ.	Max.	Unit
ZO	Current Source Output Impedance ⁽²⁾	VO = Vx	3000	—	—	Ω
VOH3	Output HIGH Voltage	IOH = -1mA	2.4	—	—	V
VOL3	Output LOW Voltage	IOL = 1mA	—	—	0.4	V
VHIGH	Voltage HIGH ⁽²⁾	Statistical measurement on single-ended signal using oscilloscope math function	660	—	1150	mV
VLOW	Voltage LOW ⁽²⁾		-300	—	150	
VOVS	Max Voltage ⁽²⁾	Measurement on single-ended signal using absolute value	—	—	1150	mV
VUDS	Min Voltage ⁽²⁾		-300	—	—	
VCROSS(ABS)	Crossing Voltage (abs) ⁽²⁾		250	—	550	mV
d - VCROSS	Crossing Voltage (var) ⁽²⁾	Variation of crossing over all edges	—	—	140	mV
ppm	Long Accuracy ^(2,3)	See TPERIOD Min. - Max. values	-300	—	300	ppm
TPERIOD	Average Period ⁽³⁾	400MHz nominal / -0.5% spread	2.4993	—	2.5133	ns
		333.33MHz nominal / -0.5% spread	2.9991	—	3.016	
		266.66MHz nominal / -0.5% spread	3.7489	—	3.77	
		200MHz nominal / -0.5% spread	4.9985	—	5.0266	
		166.66MHz nominal / -0.5% spread	5.9982	—	6.032	
		133.33MHz nominal / -0.5% spread	7.4978	—	7.54	
		100MHz nominal / -0.5% spread	9.997	—	10.0533	
TABSMIN	Absolute Min Period ^(2,3)	400MHz nominal / -0.5% spread	2.4143	—	—	ns
		333.33MHz nominal / -0.5% spread	2.9141	—	—	
		266.66MHz nominal / -0.5% spread	3.6639	—	—	
		200MHz nominal / -0.5% spread	4.9135	—	—	
		166.66MHz nominal / -0.5% spread	5.9132	—	—	
		133.33MHz nominal / -0.5% spread	7.4128	—	—	
		100MHz nominal / -0.5% spread	9.912	—	—	
tr	Rise Time ⁽²⁾	VOL = 0.175V, VOH = 0.525V	175	—	700	ps
tf	Fall Time ⁽²⁾	VOL = 0.175V, VOH = 0.525V	175	—	700	ps
d-tr	Rise Time Variation ⁽²⁾		—	—	125	ps
d-tf	Fall Time Variation ⁽²⁾		—	—	125	ps
dT3	Duty Cycle ⁽²⁾	Measurement from differential waveform	45	—	55	%
tsk3	Skew, CPU[1:0] ⁽²⁾	VT = 50%	—	—	100	ps
	Skew, CPU2 ⁽²⁾		—	—	250	
	Skew, SRC ⁽²⁾		—	—	250	
tjyc-cyc	Jitter, Cycle to Cycle, CPU[1:0] ⁽²⁾	Measurement from differential waveform	—	—	85	ps
	Jitter, Cycle to Cycle, CPU2 ⁽²⁾		—	—	100	
	Jitter, Cycle to Cycle, SRC ⁽²⁾		—	—	125	

NOTES:

- SRC clock outputs run only at 100MHz.
- This parameter is guaranteed by design, but not 100% production tested.
- All long term accuracy and clock period specifications are guaranteed with the assumption that the REF output is at 14.31818MHz.

ELECTRICAL CHARACTERISTICS - PCICKL

Following Conditions Apply Unless Otherwise Specified:

Operating Condition: $T_A = 0^\circ\text{C}$ to $+70^\circ\text{C}$, Supply Voltage: $V_{DD} = 3.3\text{V} \pm 5\%$; $C_L = 10 - 30\text{pF}$

Symbol	Parameter	Test Conditions	Min.	Typ.	Max.	Unit
ppm	Long Accuracy ^(1,2)	See Tperiod Min. - Max. values	—	—	300	ppm
TPERIOD	Clock Period ⁽²⁾	33.33MHz output nominal	29.991	—	30.009	ns
		33.33MHz output spread	29.991	—	30.1598	
VOH	Output HIGH Voltage	IOH = -1mA	2.4	—	—	V
VOL	Output LOW Voltage	IOL = 1mA	—	—	0.55	V
IOH	Output HIGH Current	VOH at Min. = 1V	-33	—	—	mA
		VOH at Max. = 3.135V	—	—	-33	
IOL	Output LOW Current	VOL at Min. = 1.95V	30	—	—	mA
		VOL at Max. = 0.4V	—	—	38	
	Edge Rate ⁽¹⁾	Rising edge rate	1	—	4	V/ns
	Edge Rate ⁽¹⁾	Falling edge rate	1	—	4	V/ns
tR1	Rise Time ⁽¹⁾	VOL = 0.8V, VOH = 2V	0.3	—	1.2	ns
tF1	Fall Time ⁽¹⁾	VOL = 0.8V, VOH = 2V	0.3	—	1.2	ns
dT1	Duty Cycle ⁽¹⁾	VT = 1.5V	45	—	55	%
tJCYC-CYC	Jitter, Cycle to Cycle ⁽¹⁾	VT = 1.5V	—	—	500	ps

NOTES:

1. This parameter is guaranteed by design, but not 100% production tested.
2. All long term accuracy and clock period specifications are guaranteed with the assumption that the REF output is at 14.31818MHz.

ELECTRICAL CHARACTERISTICS - 48MHZ, USB

Following Conditions Apply Unless Otherwise Specified:

Operating Condition: $T_A = 0^\circ\text{C}$ to $+70^\circ\text{C}$, Supply Voltage: $V_{DD} = 3.3\text{V} \pm 5\%$; $C_L = 10 - 20\text{pF}$

Symbol	Parameter	Test Conditions	Min.	Typ.	Max.	Unit
ppm	Long Accuracy ^(1,2)	See Tperiod Min. - Max. values	—	—	300	ppm
TPERIOD	Clock Period ⁽²⁾	48MHz output nominal	20.8257	—	20.834	ns
VOH	Output HIGH Voltage	IOH = -1mA	2.4	—	—	V
VOL	Output LOW Voltage	IOL = 1mA	—	—	0.55	V
IOH	Output HIGH Current	VOH at Min. = 1V	-29	—	—	mA
		VOH at Max. = 3.135V	—	—	-23	
IOL	Output LOW Current	VOL at Min. = 1.95V	29	—	—	mA
		VOL at Max. = 0.4V	—	—	27	
	Edge Rate ⁽¹⁾	Rising edge rate	1	—	2	V/ns
	Edge Rate ⁽¹⁾	Falling edge rate	1	—	2	V/ns
tR1	Rise Time ⁽¹⁾	VOL = 0.8V, VOH = 2V	0.5	—	1.2	ns
tF1	Fall Time ⁽¹⁾	VOL = 0.8V, VOH = 2V	0.5	—	1.2	ns
dT1	Duty Cycle ⁽¹⁾	VT = 1.5V	45	—	55	%
tJCYC-CYC	Jitter, Cycle to Cycle ⁽¹⁾	VT = 1.5V	—	—	350	ps

NOTES:

1. This parameter is guaranteed by design, but not 100% production tested.
2. All long term accuracy and clock period specifications are guaranteed with the assumption that the REF output is at 14.31818MHz.

ELECTRICAL CHARACTERISTICS - REF-14.318MHZ

Following Conditions Apply Unless Otherwise Specified:

Operating Condition: TA = 0°C to +70°C, Supply Voltage: VDD = 3.3V ± 5%; CL = 10 - 20pF

Symbol	Parameter	Test Conditions	Min.	Typ.	Max.	Unit
ppm	Long Accuracy ⁽¹⁾	See Tperiod Min. - Max. values	—	—	0	ppm
TPERIOD	Clock Period	14.318MHz output nominal	69.827	—	69.855	ns
VOH	Output HIGH Voltage ⁽¹⁾	IOH = -1mA	2.4	—	—	V
VOL	Output LOW Voltage ⁽¹⁾	IOL = 1mA	—	—	0.4	V
IOH	Output HIGH Current	VOH at Min. = 1V	-33	—	—	mA
		VOH at Max. = 3.135V	—	—	-33	
IOL	Output LOW Current	VOL at Min. = 1.95V	30	—	—	mA
		VOL at Max. = 0.4V	—	—	38	
	Edge Rate ⁽¹⁾	Rising edge rate	1	—	4	V/ns
	Edge Rate ⁽¹⁾	Falling edge rate	1	—	4	V/ns
tR1	Rise Time ⁽¹⁾	VOL = 0.8V, VOH = 2V	0.3	—	1.2	ns
tF1	Fall Time ⁽¹⁾	VOL = 0.8V, VOH = 2V	0.3	—	1.2	ns
dT1	Duty Cycle ⁽¹⁾	VT = 1.5V	45	—	55	%
tJCYC-CYC	Jitter, Cycle to Cycle ⁽¹⁾	VT = 1.5V	—	—	1000	ps

NOTE:

1. This parameter is guaranteed by design, but not 100% production tested.

PD, POWER DOWN

PD is an asynchronous active high input used to shut off all clocks cleanly prior to clock power. When PD is asserted high all clocks will be driven low before turning off the VCO. In PD de-assertion all clocks will start without glitches.

PD	CPU	CPU#	SRC	SRC#	PCI	USB	REF
0	Normal	Normal	Normal	Normal	33MHz	48MHz	14.318MHz
1	IREF * 2 or float	Float	IREF * 2 or float	Float	Low	Low	Low

PD ASSERTION

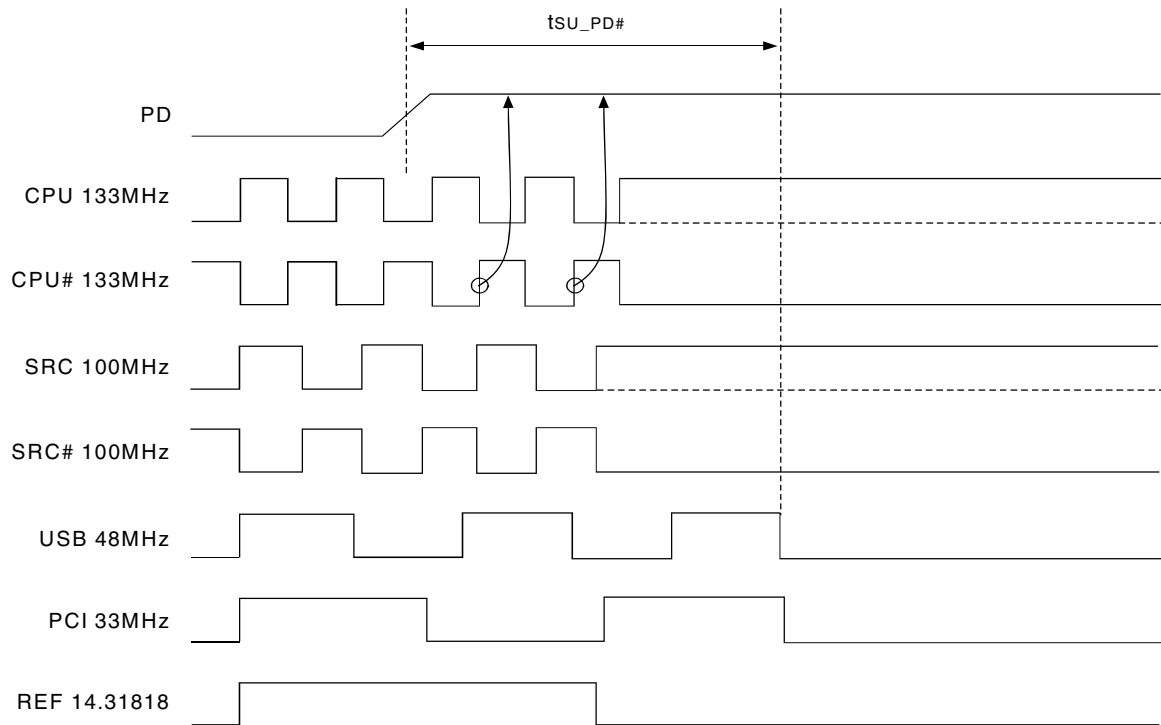

PD DE-ASSERTION

The time from the de-assertion of PD or until power supply ramps to get stable clocks will be less than 1.8ms. If the drive mode control bit for PD tristate is programmed to '1' the stopped differential pair must first be driven high to a minimum of 200mV in less than 300µs of PD deassertion.

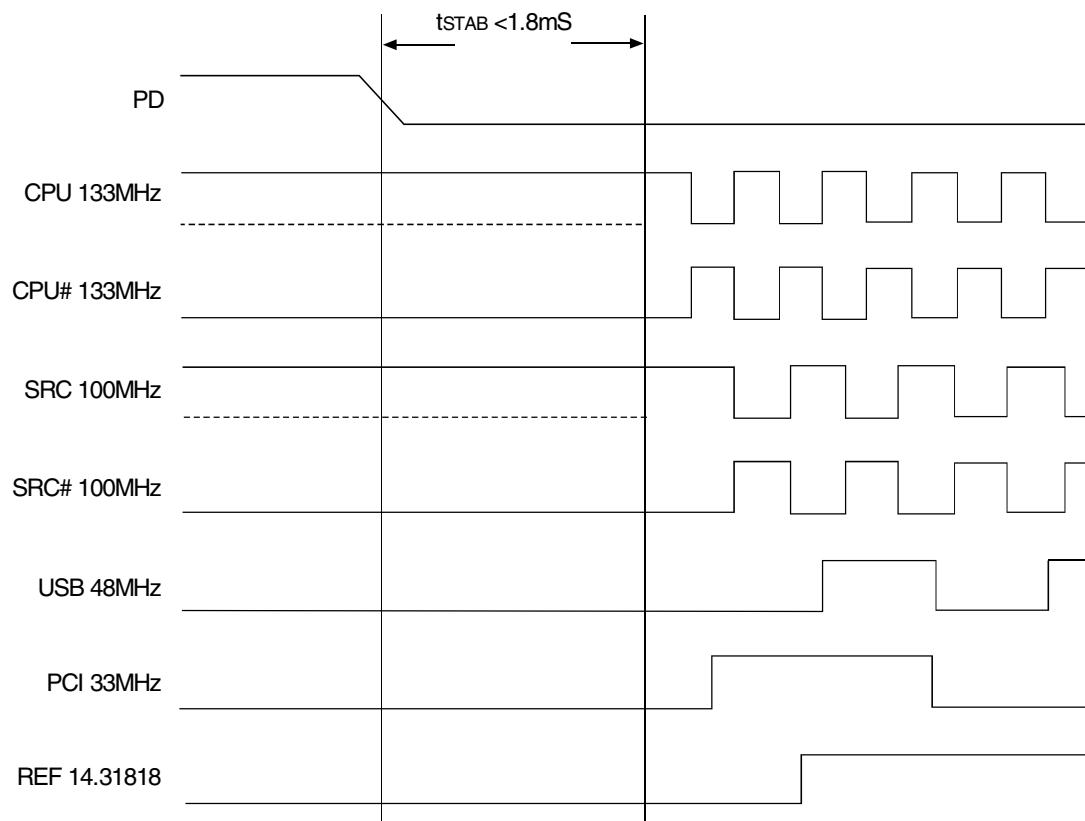

CPU_STOP# ASSERTION

The clock samples the CPU_STOP# signal on a rising edge of CPU clock. After detecting the CPU_STOP# assertion low, all controlled CPU clocks will be tristate on their next high to low transition.

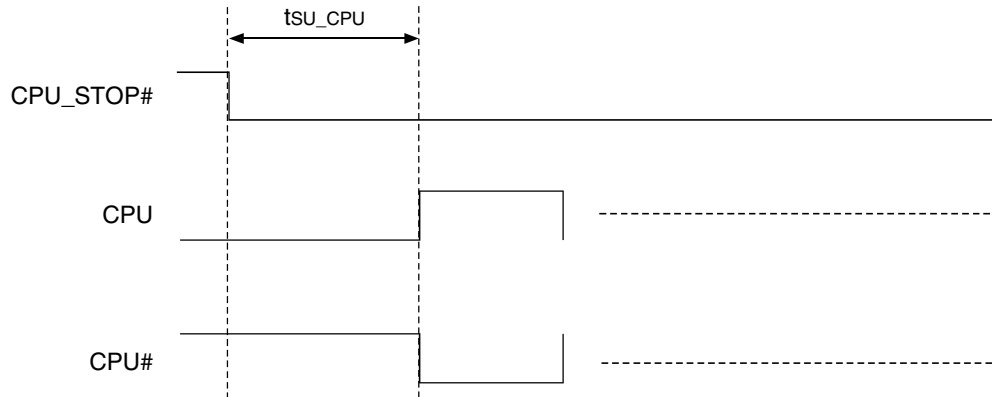

CPU_STOP# - DE-ASSERTION

After detecting CPU_STOP# de-assertion, all controlled CPU clocks will resume in a glitch free manner.

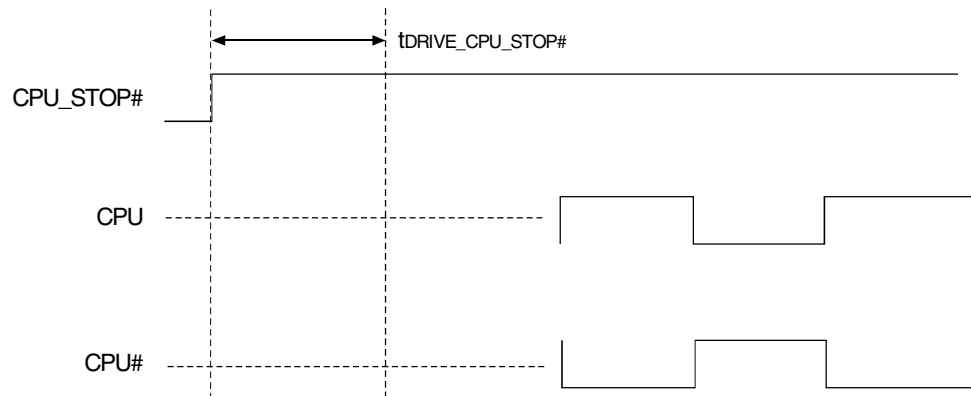

CLKREQ# DE-ASSERTION

The clock samples the CLKREQ# signal on a rising edge of SRC clock. After detecting the CLKREQ# de-assertion high, all controlled SRC clocks will be tristate on their next high to low transition.

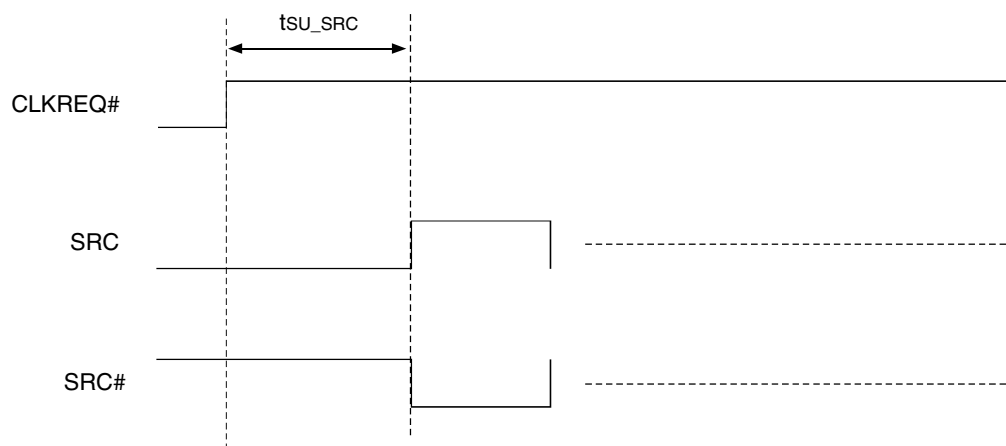

CLKREQ# ASSERTION

The assertion of the CLKREQ# signal is to be sampled on the rising edge of the SRC free running clock domain. After detecting CLKREQ# assertion, all controlled SRC clocks will resume in a glitch free manner.

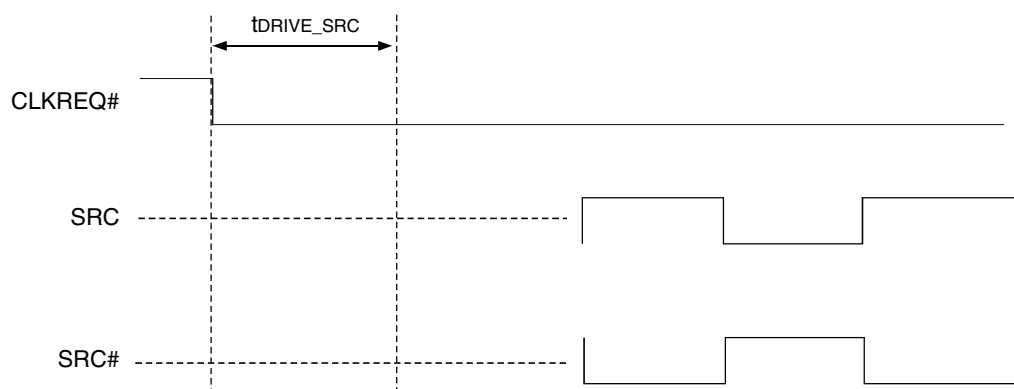

ORDERING INFORMATION

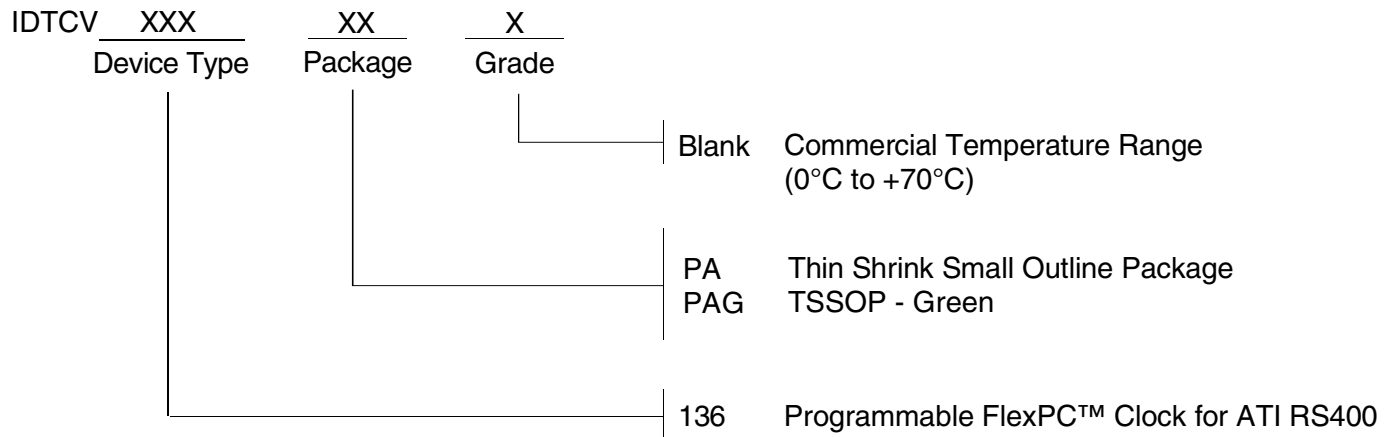

IMPORTANT NOTICE AND DISCLAIMER

RENESAS ELECTRONICS CORPORATION AND ITS SUBSIDIARIES (“RENESAS”) PROVIDES TECHNICAL SPECIFICATIONS AND RELIABILITY DATA (INCLUDING DATASHEETS), DESIGN RESOURCES (INCLUDING REFERENCE DESIGNS), APPLICATION OR OTHER DESIGN ADVICE, WEB TOOLS, SAFETY INFORMATION, AND OTHER RESOURCES “AS IS” AND WITH ALL FAULTS, AND DISCLAIMS ALL WARRANTIES, EXPRESS OR IMPLIED, INCLUDING, WITHOUT LIMITATION, ANY IMPLIED WARRANTIES OF MERCHANTABILITY, FITNESS FOR A PARTICULAR PURPOSE, OR NON-INFRINGEMENT OF THIRD PARTY INTELLECTUAL PROPERTY RIGHTS.

These resources are intended for developers skilled in the art designing with Renesas products. You are solely responsible for (1) selecting the appropriate products for your application, (2) designing, validating, and testing your application, and (3) ensuring your application meets applicable standards, and any other safety, security, or other requirements. These resources are subject to change without notice. Renesas grants you permission to use these resources only for development of an application that uses Renesas products. Other reproduction or use of these resources is strictly prohibited. No license is granted to any other Renesas intellectual property or to any third party intellectual property. Renesas disclaims responsibility for, and you will fully indemnify Renesas and its representatives against, any claims, damages, costs, losses, or liabilities arising out of your use of these resources. Renesas' products are provided only subject to Renesas' Terms and Conditions of Sale or other applicable terms agreed to in writing. No use of any Renesas resources expands or otherwise alters any applicable warranties or warranty disclaimers for these products.

(Disclaimer Rev.1.0 Mar 2020)

Corporate Headquarters

TOYOSU FORESIA, 3-2-24 Toyosu,
Koto-ku, Tokyo 135-0061, Japan
www.renesas.com

Contact Information

For further information on a product, technology, the most up-to-date version of a document, or your nearest sales office, please visit:
www.renesas.com/contact/

Trademarks

Renesas and the Renesas logo are trademarks of Renesas Electronics Corporation. All trademarks and registered trademarks are the property of their respective owners.