

REVISIONS			
REV	DESCRIPTION, ECN, EAR NO.	DATE	APP'D
A	PROPOSAL DRAWING	MAR25/14	L.CHAN

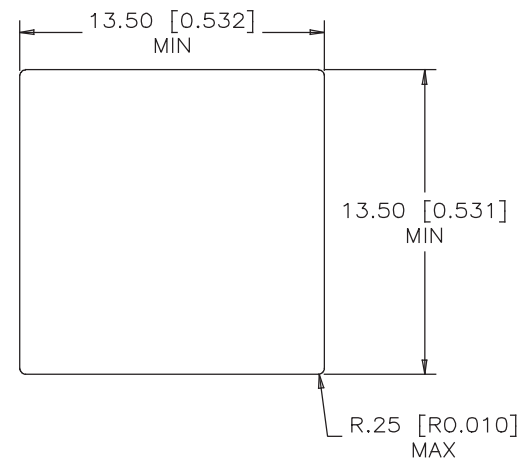

RECOMMENDED PANEL CUTOUT

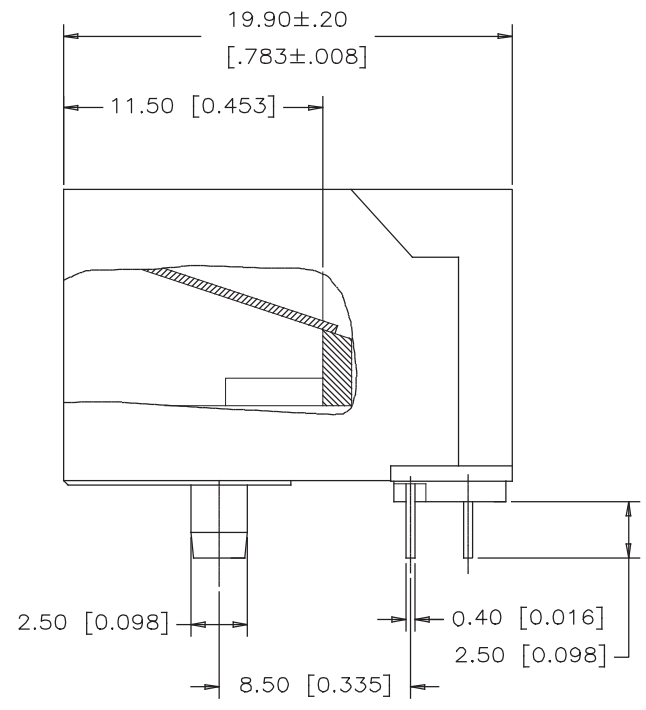
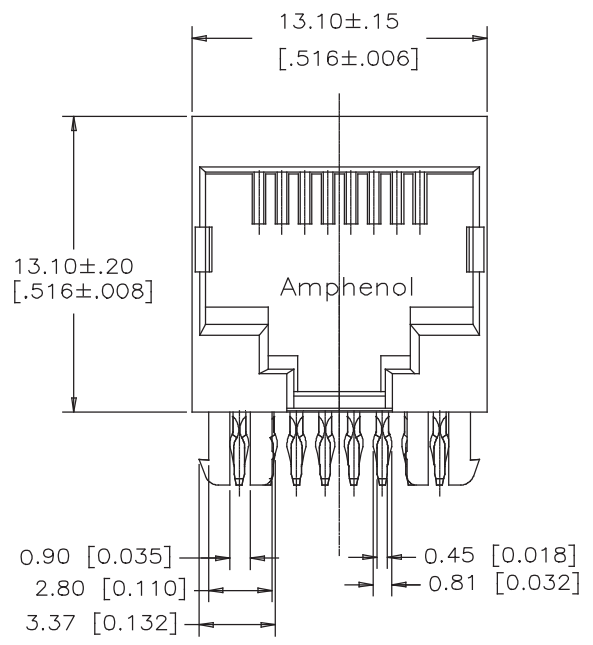
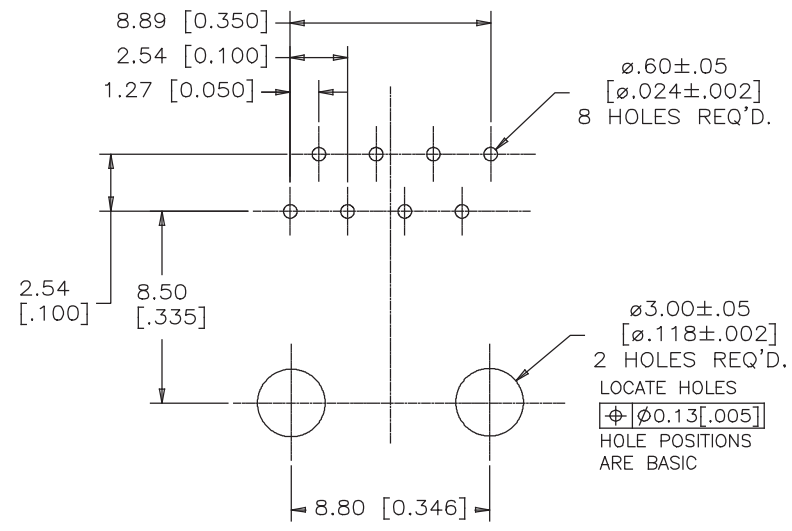

RECOMMENDED P.C.B LAYOUT
(COMPONENT SIDE OF BOARD)
TOLERANCES: +/-0.05[.002]



1. MATERIALS:

PLASTIC HOUSING: ENGINEERING THERMOPLASTIC
FLAMMABILITY RATING UL94V-0
COLOR: BLACK

CONTACTS: PHOSPHOR BRONZE
PLATING: 50 μ" [1.27 MICRONS] MIN. GOLD PLATE ON MATING SURFACE
50 μ" [1.27 MICRONS] MIN. NICKEL UNDERPLATE.
100 μ" [2.54 MICRONS] MIN. MATTE TIN ON CONTACT TAILS.

2. THE REMOVAL FORCE OF PRESS FIT CONTACT SHOULD BE IN RANGE OF 10N PER PIN.

UNLESS SPECIFIED OTHERWISE	DRAWN	J.FENG	MAR25/14
PRIMARY UNITS MILLIMETERS	CHECKED	L.CHAN	MAR25/14
SECONDARY INCH	M.E. APP'D		
REFERENCE IN PARENTHESES	Q.A. APP'D		
GENERAL TOLERANCES IN MM	DWG APP'D	L.CHAN	MAR25/14
1 DECIMAL PLACE ±0.38	ENG. REL. NO.		
2 DECIMAL PLACES ±0.25	REF.		
3 DECIMAL PLACES	THIRD ANGLE PROJECTION		
ANGULAR DEGREES ±1.5°	DO NOT SCALE DRAWING		

Amphenol Canada Corp.			
TITLE			
RJE56 SERIES, 8 POSITION, 8 CONTACTS, RoHS COMPLIANT			
DWG NO.			REV
P-RJE56-188-0410			A
CODE ID NO. D3554	DWG SIZE C	SCALE N/A	SHEET 1 OF 2

REVISIONS			
REV	DESCRIPTION, ECN, EAR NO.	DATE	APP'D
A	PROPOSAL DRAWING	MAR25/14	L.CHAN

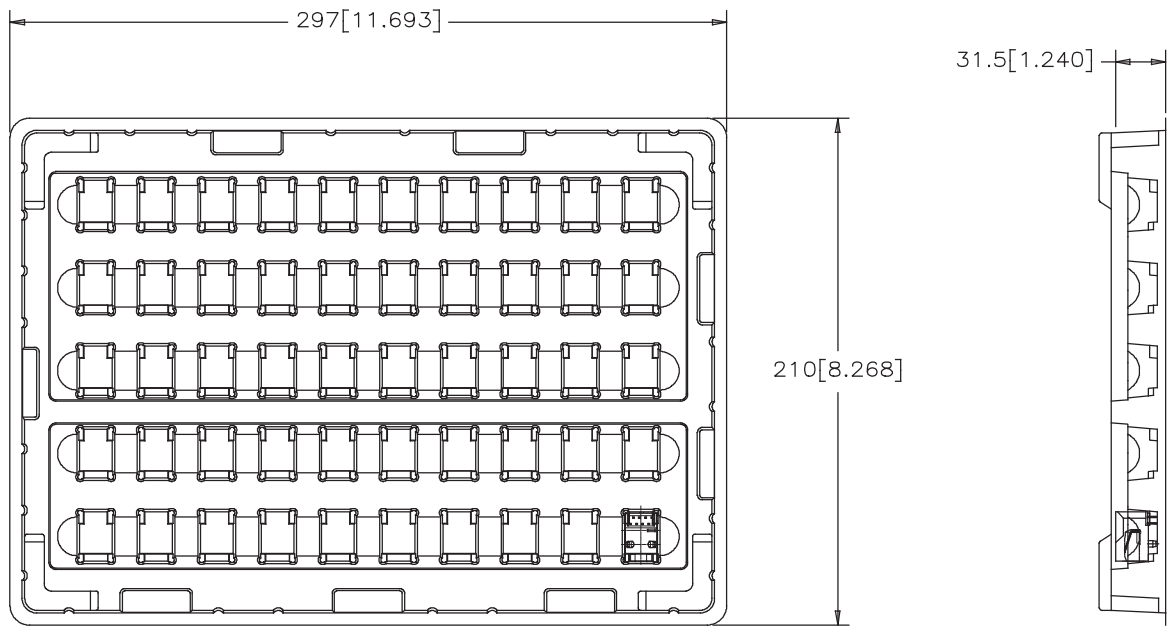

PACKAGING NOTES:

1. ONE TRAY SHOULD HOLD 50 CONNECTORS.
2. A FULLY LOADED CARTON SHOULD CONTAIN 10 TRAY (500 PCS) OF CONNECTORS.

UNLESS SPECIFIED OTHERWISE	DRAWN	J.FENG	MAR25/14	Amphenol Canada Corp.
PRIMARY UNITS MILLIMETERS	CHECKED	L.CHAN	MAR25/14	
SECONDARY INCH	M.E. APP'D			TITLE
REFERENCE IN PARENTHESES	Q.A. APP'D			
GENERAL TOLERANCES IN MM	DWG APP'D	L.CHAN	MAR25/14	RJE56 SERIES, 8 POSITION, 8 CONTACTS, RoHS COMPLIANT
1 DECIMAL PLACE ±0.38	ENG. REL. NO.			
2 DECIMAL PLACES ±0.25	REF.			DWG NO.
3 DECIMAL PLACES	THIRD ANGLE PROJECTION			P-RJE56-188-0410
ANGULAR DEGREES ±1.5°	DO NOT SCALE DRAWING			REV A
CODE ID NO. 03554				DWG SIZE C
SCALE N/A				SHEET 2 OF 2

THIS DOCUMENT CONTAINS PROPRIETARY INFORMATION AND SUCH INFORMATION MAY NOT BE DISCLOSED TO OTHERS FOR ANY PURPOSE OR USED FOR MANUFACTURING PURPOSES WITHOUT WRITTEN PERMISSION FROM AMPHENOL CANADA CORP.