

Very low-dropout voltage regulator with inhibit function

Datasheet - production data

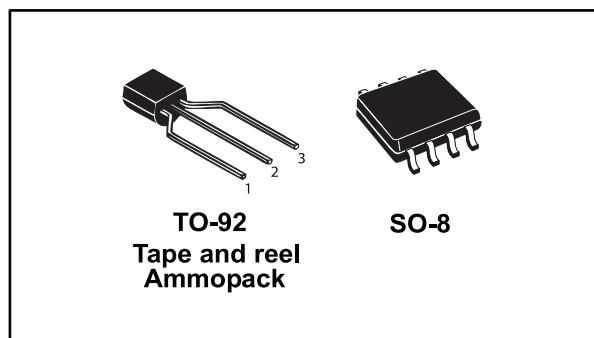

Description

The LEXX is a very low-dropout voltage regulator available in SO-8, TO-92 packages and over a wide range of output voltages.

The very low-dropout voltage (0.2 V) and low quiescent current make it particularly suitable for low-noise, low-power applications and in battery-powered systems.

This device is pin-to-pin compatible with the L78L series. Furthermore, in the 8-pin configuration (SO-8), it uses a shutdown logic control (pin 5, TTL compatible). This means that when the device is used as a local regulator, a part of the board can be put in standby, decreasing the total power consumption. In the three-terminal configuration (TO-92), the device is always in on-state. It requires a 2.2 μ F capacitor for stability, reducing the component size and cost.

Features

- Very low-dropout voltage (0.2 V typ.)
- Very low quiescent current (typ. 50 μ A in OFF mode, 0.5 mA in ON mode, no load)
- Output current up to 100 mA
- Output voltages: 3 V, 3.3 V, 4.5 V, 5 V, 8 V
- Internal current and thermal limit
- Small 2.2 μ F capacitor for stability
- Available in $\pm 1\%$ (A) or $\pm 2\%$ (C) selection at 25 $^{\circ}$ C
- Supply voltage rejection: 80 dB (typ.)
- Temperature range: -40 to 125 $^{\circ}$ C

Table 1: Device summary

Order code			Output voltage (V)
SO-8	TO-92 (Ammopack)	TO-92 (tape and reel)	
LE30CD-TR			3
LE33CD-TR	LE33CZ-AP	LE33CZ-TR	3.3
LE45CD-TR			4.5
LE50ABD-TR	LE33ABZ-AP		5
LE50CD-TR			5
LE80CD-TR			8

Contents

1	Diagram	3
2	Pin configuration	4
3	Maximum ratings	5
4	Electrical characteristics	6
5	Typical performance characteristics	13
6	Package information	16
	6.1 SO-8 package information	16
	6.2 SO-8 packing information.....	18
	6.3 TO-92 packing information.....	19
	6.4 TO-92 Ammopak packing information.....	21
7	Revision history	23

1 Diagram

Figure 1: Block diagram

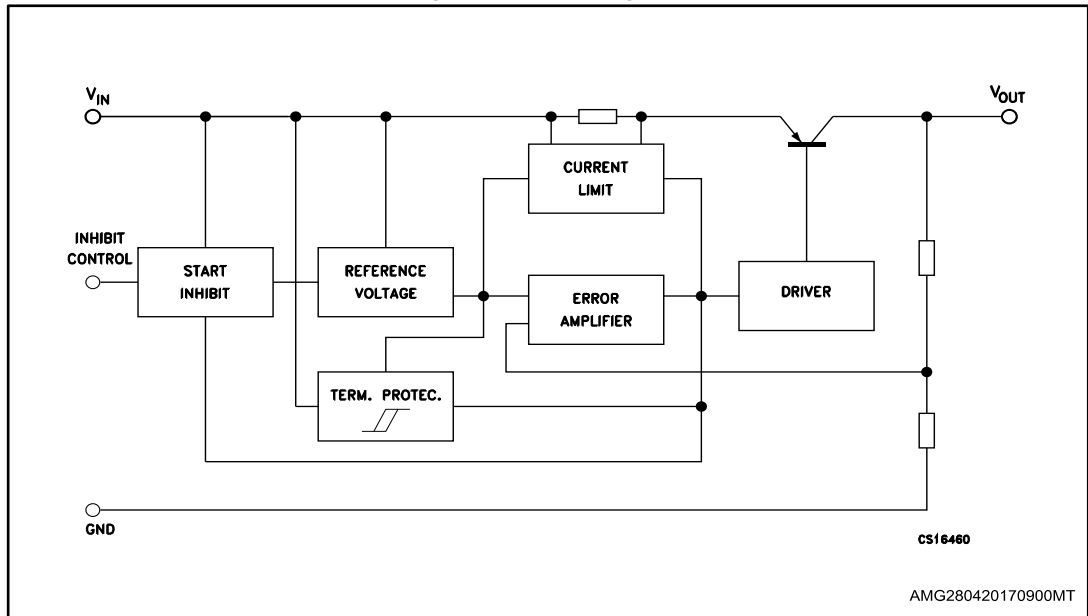

2 Pin configuration

Figure 2: Pin connections (SO-8 top view, TO-92 bottom view)

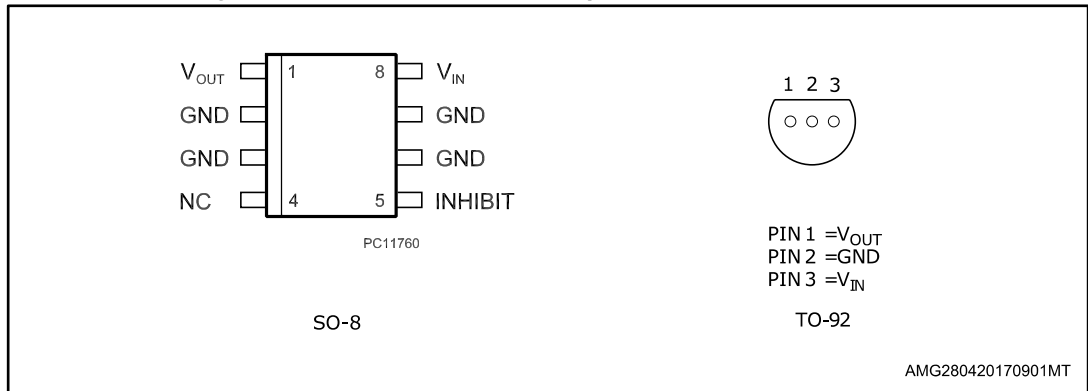

3 Maximum ratings

Table 2: Absolute maximum ratings

Symbol	Parameter	Value	Unit
V_I	DC input voltage	20	V
I_O	Output current	Internally limited ⁽¹⁾	
P_{TOT}	Power dissipation	Internally limited	
T_{STG}	Storage temperature range	-65 to 150	°C
T_{OP}	Operating junction temperature range	-40 to 125	°C

Notes:

⁽¹⁾Our SO-8 package, used for voltage regulators, is modified internally to have pins 2, 3, 6 and 7 electrically fused to the die attach pad. This frame decreases the total thermal resistance of the package and increases its ability to dissipate power when an appropriate area of copper on the printed circuit board is available for heatsinking. The external dimensions are the same as SO-8 standard.

Table 3: Thermal data

Symbol	Parameter	SO-8	TO-92	Unit
R_{thJC}	Thermal resistance junction-case	20		°C/W
R_{thJA}	Thermal resistance junction-ambient	55	200	°C/W

Figure 3: Test circuit

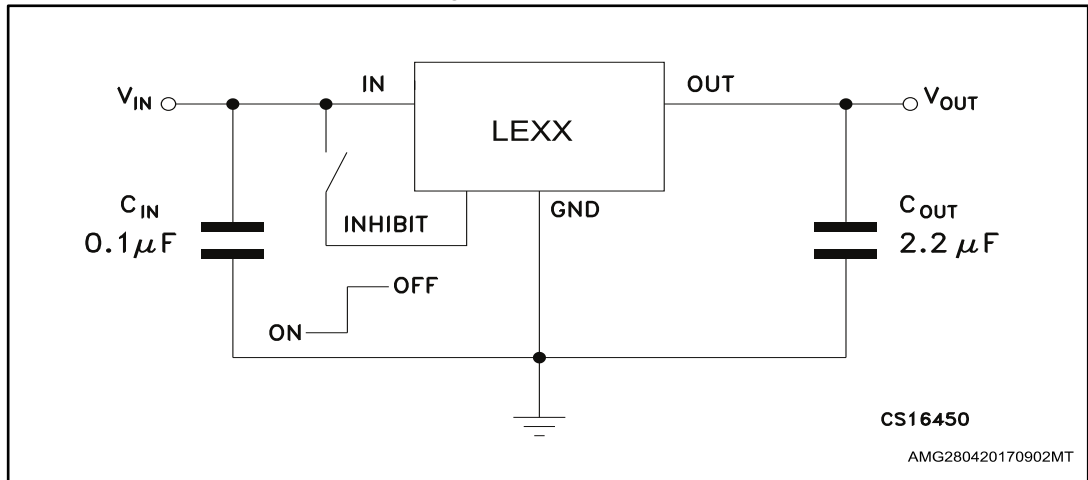

If the INHIBIT pin is left floating, the regulator is in ON mode. However, when the inhibit function is not used, it should be grounded to avoid any noise.

4 Electrical characteristics

Refer to test circuits, $T_J = 25\text{ }^\circ\text{C}$, $C_I = 0.1\text{ }\mu\text{F}$, $C_O = 2.2\text{ }\mu\text{F}$ unless otherwise specified.

Table 4: LE30AB electrical characteristics

Symbol	Parameter	Test condition	Min.	Typ.	Max.	Unit	
V_O	Output voltage	$I_O = 10\text{ mA}$ $V_I = 5\text{ V}$	2.970	3	3.030	V	
		$I_O = 10\text{ mA}$ $V_I = 5\text{ V}$ $T_J = -25\text{ to }85\text{ }^\circ\text{C}$	2.940		3.060		
V_I	Operating input voltage	$I_O = 100\text{ mA}$			18	V	
I_O	Output current limit		150			mA	
ΔV_O	Line regulation	$V_I = 3.7\text{ to }18\text{ V}$ $I_O = 0.5\text{ mA}$		3	15	mV	
ΔV_O	Load regulation	$V_I = 4\text{ V}$ $I_O = 0.5\text{ to }100\text{ mA}$		3	15	mV	
I_d	Quiescent current	$V_I = 4\text{ to }18\text{ V}$ $I_O = 0\text{ mA}$	ON mode		0.5	1	mA
		$V_I = 4\text{ to }18\text{ V}$ $I_O = 100\text{ mA}$			1.5	3	
		$V_I = 6\text{ V}$	OFF mode		50	100	μA
SVR	Supply voltage rejection	$I_O = 5\text{ mA}$ $V_I = 5 \pm 1\text{ V}$	$f = 120\text{ Hz}$		81		dB
			$f = 1\text{ kHz}$		76		
			$f = 10\text{ kHz}$		60		
eN	Output noise voltage	$B = 10\text{ Hz to }100\text{ kHz}$		50		μV	
V_d	Dropout voltage	$I_O = 100\text{ mA}$		0.2	0.4	V	
		$I_O = 100\text{ mA}$ $T_J = -40\text{ to }125\text{ }^\circ\text{C}$			0.5		
V_{IL}	Control input logic low	$T_J = -40\text{ to }125\text{ }^\circ\text{C}$			0.8	V	
V_{IH}	Control input logic high	$T_J = -40\text{ to }125\text{ }^\circ\text{C}$	2			V	
I_i	Control input current	$V_I = 6\text{ V}$ $V_C = 6\text{ V}$		10		μA	
C_O	Output bypass capacitance	ESR = 0.1 to 10 Ω $I_O = 0\text{ to }100\text{ mA}$	2	10		μF	

Refer to test circuits, $T_J = 25\text{ °C}$, $C_I = 0.1\text{ }\mu\text{F}$, $C_O = 2.2\text{ }\mu\text{F}$ unless otherwise specified.

Table 5: LE30C electrical characteristics

Symbol	Parameter	Test condition	Min.	Typ.	Max.	Unit	
V_O	Output voltage	$I_O = 10\text{ mA}$ $V_I = 5\text{ V}$	2.940	3	3.060	V	
		$I_O = 10\text{ mA}$ $V_I = 5\text{ V}$ $T_J = -25\text{ to }85\text{ °C}$	2.880		3.120		
V_I	Operating input voltage	$I_O = 100\text{ mA}$			18	V	
I_O	Output current limit		150			mA	
ΔV_O	Line regulation	$V_I = 3.7\text{ to }18\text{ V}$ $I_O = 0.5\text{ mA}$		3	20	mV	
ΔV_O	Load regulation	$V_I = 4\text{ V}$ $I_O = 0.5\text{ to }100\text{ mA}$		3	25	mV	
I_d	Quiescent current	$V_I = 4\text{ to }18\text{ V}$ $I_O = 0\text{ mA}$	ON mode		0.5	1	mA
		$V_I = 4\text{ to }18\text{ V}$ $I_O = 100\text{ mA}$			1.5	3	
		$V_I = 6\text{ V}$	OFF mode		50	100	μA
SVR	Supply voltage rejection	$I_O = 5\text{ mA}$ $V_I = 5 \pm 1\text{ V}$	$f = 120\text{ Hz}$		81	dB	
			$f = 1\text{ kHz}$		76		
			$f = 10\text{ kHz}$		60		
eN	Output noise voltage	$B = 10\text{ Hz to }100\text{ kHz}$		50		μV	
V_d	Dropout voltage	$I_O = 100\text{ mA}$		0.2	0.4	V	
		$I_O = 100\text{ mA}$ $T_J = -40\text{ to }125\text{ °C}$			0.5		
V_{IL}	Control input logic low	$T_J = -40\text{ to }125\text{ °C}$			0.8	V	
V_{IH}	Control input logic high	$T_J = -40\text{ to }125\text{ °C}$	2			V	
I_I	Control input current	$V_I = 6\text{ V}$ $V_C = 6\text{ V}$		10		μA	
C_O	Output bypass capacitance	ESR = 0.1 to 10 Ω $I_O = 0\text{ to }100\text{ mA}$	2	10		μF	

Refer to test circuits, $T_J = 25\text{ °C}$, $C_I = 0.1\text{ }\mu\text{F}$, $C_O = 2.2\text{ }\mu\text{F}$ unless otherwise specified.

Table 6: LE33C electrical characteristics

Symbol	Parameter	Test condition	Min.	Typ.	Max.	Unit	
V_O	Output voltage	$I_O = 10\text{ mA}$ $V_I = 5.3\text{ V}$	3.234	3.3	3.366	V	
		$I_O = 10\text{ mA}$ $V_I = 5.3\text{ V}$ $T_J = -25\text{ to }85\text{ °C}$	3.168		3.432		
V_I	Operating input voltage	$I_O = 100\text{ mA}$			18	V	
I_O	Output current limit		150			mA	
ΔV_O	Line regulation	$V_I = 4\text{ to }18\text{ V}$ $I_O = 0.5\text{ mA}$		3	20	mV	
ΔV_O	Load regulation	$V_I = 4.3\text{ V}$ $I_O = 0.5\text{ to }100\text{ mA}$		3	25	mV	
I_d	Quiescent current	$V_I = 4.3\text{ to }18\text{ V}$ $I_O = 0\text{ mA}$	ON mode		0.5	1	mA
		$V_I = 4.3\text{ to }18\text{ V}$ $I_O = 100\text{ mA}$			1.5	3	
		$V_I = 6\text{ V}$	OFF mode		50	100	μA
SVR	Supply voltage rejection	$I_O = 5\text{ mA}$ $V_I = 5.3 \pm 1\text{ V}$	$f = 120\text{ Hz}$		80		dB
			$f = 1\text{ kHz}$		75		
			$f = 10\text{ kHz}$		60		
eN	Output noise voltage	$B = 10\text{ Hz to }100\text{ kHz}$		50		μV	
V_d	Dropout voltage	$I_O = 100\text{ mA}$		0.2	0.4	V	
		$I_O = 100\text{ mA}$ $T_J = -40\text{ to }125\text{ °C}$			0.5		
V_{IL}	Control input logic low	$T_J = -40\text{ to }125\text{ °C}$			0.8	V	
V_{IH}	Control input logic high	$T_J = -40\text{ to }125\text{ °C}$	2			V	
I_i	Control input current	$V_I = 6\text{ V}$ $V_C = 6\text{ V}$		10		μA	
C_O	Output bypass capacitance	ESR = 0.1 to 10 Ω $I_O = 0\text{ to }100\text{ mA}$	2	10		μF	

Refer to test circuits, $T_J = 25\text{ }^\circ\text{C}$, $C_I = 0.1\text{ }\mu\text{F}$, $C_O = 2.2\text{ }\mu\text{F}$ unless otherwise specified.

Table 7: LE45C electrical characteristics

Symbol	Parameter	Test condition	Min.	Typ.	Max.	Unit
V_O	Output voltage	$I_O = 10\text{ mA}$ $V_I = 6.5\text{ V}$	4.41	4.5	4.59	V
		$I_O = 10\text{ mA}$ $V_I = 6.5\text{ V}$ $T_J = -25\text{ to }85\text{ }^\circ\text{C}$	4.32		4.68	
V_I	Operating input voltage	$I_O = 100\text{ mA}$			18	V
I_O	Output current limit		150			mA
ΔV_O	Line regulation	$V_I = 5.2\text{ to }18\text{ V}$ $I_O = 0.5\text{ mA}$		4	30	mV
ΔV_O	Load regulation	$V_I = 5.5\text{ V}$ $I_O = 0.5\text{ to }100\text{ mA}$		3	25	mV
I_d	Quiescent current	$V_I = 5.5\text{ to }18\text{ V}$ $I_O = 0\text{ mA}$	ON mode	0.5	1	mA
		$V_I = 5.5\text{ to }18\text{ V}$ $I_O = 100\text{ mA}$		1.5	3	
		$V_I = 6\text{ V}$	OFF mode	50	100	μA
SVR	Supply voltage rejection	$I_O = 5\text{ mA}$ $V_I = 6.5 \pm 1\text{ V}$	$f = 120\text{ Hz}$		77	dB
			$f = 1\text{ kHz}$		72	
			$f = 10\text{ kHz}$		60	
eN	Output noise voltage	$B = 10\text{ Hz to }100\text{ kHz}$		50		μV
V_d	Dropout voltage	$I_O = 100\text{ mA}$		0.2	0.4	V
		$I_O = 100\text{ mA}$ $T_J = -40\text{ to }125\text{ }^\circ\text{C}$			0.5	
V_{IL}	Control input logic low	$T_J = -40\text{ to }125\text{ }^\circ\text{C}$			0.8	V
V_{IH}	Control input logic high	$T_J = -40\text{ to }125\text{ }^\circ\text{C}$	2			V
I_i	Control input current	$V_I = 6\text{ V}$ $V_C = 6\text{ V}$		10		μA
C_O	Output bypass capacitance	ESR = 0.1 to 10 Ω $I_O = 0\text{ to }100\text{ mA}$	2	10		μF

Refer to test circuits, $T_J = 25\text{ °C}$, $C_I = 0.1\text{ }\mu\text{F}$, $C_O = 2.2\text{ }\mu\text{F}$ unless otherwise specified.

Table 8: LE50AB electrical characteristics

Symbol	Parameter	Test condition	Min.	Typ.	Max.	Unit	
V_O	Output voltage	$I_O = 10\text{ mA}$ $V_I = 7\text{ V}$	4.95	5	5.05	V	
		$I_O = 10\text{ mA}$ $V_I = 7\text{ V}$ $T_J = -25\text{ to }85\text{ °C}$	4.9		5.1		
V_I	Operating input voltage	$I_O = 100\text{ mA}$			18	V	
I_O	Output current limit		150	350	425	mA	
ΔV_O	Line regulation	$V_I = 5.7\text{ to }18\text{ V}$ $I_O = 0.5\text{ mA}$		4	20	mV	
ΔV_O	Load regulation	$V_I = 6\text{ V}$ $I_O = 0.5\text{ to }100\text{ mA}$		3	15	mV	
I_d	Quiescent current	$V_I = 6\text{ to }18\text{ V}$ $I_O = 0\text{ mA}$	ON mode		0.5	1	mA
		$V_I = 6\text{ to }18\text{ V}$ $I_O = 100\text{ mA}$			1.5	3	
		$V_I = 6\text{ V}$	OFF mode		50	100	μA
SVR	Supply voltage rejection	$I_O = 5\text{ mA}$ $V_I = 7 \pm 1\text{ V}$	$f = 120\text{ Hz}$		76	dB	
			$f = 1\text{ kHz}$		71		
			$f = 10\text{ kHz}$		60		
eN	Output noise voltage	$B = 10\text{ Hz to }100\text{ kHz}$		50		μV	
V_d	Dropout voltage	$I_O = 100\text{ mA}$		0.2	0.4	V	
		$I_O = 100\text{ mA}$ $T_J = -40\text{ to }125\text{ °C}$			0.5		
V_{IL}	Control input logic low	$T_J = -40\text{ to }125\text{ °C}$			0.8	V	
V_{IH}	Control input logic high	$T_J = -40\text{ to }125\text{ °C}$	2			V	
I_i	Control input current	$V_I = 6\text{ V}$ $V_C = 6\text{ V}$		10		μA	
C_O	Output bypass capacitance	ESR = 0.1 to 10 Ω $I_O = 0\text{ to }100\text{ mA}$	2	10		μF	

Refer to test circuits, $T_J = 25\text{ °C}$, $C_I = 0.1\text{ }\mu\text{F}$, $C_O = 2.2\text{ }\mu\text{F}$ unless otherwise specified.

Table 9: LE50C electrical characteristics

Symbol	Parameter	Test condition	Min.	Typ.	Max.	Unit	
V_O	Output voltage	$I_O = 10\text{ mA}$ $V_I = 7\text{ V}$	4.9	5	5.1	V	
		$I_O = 10\text{ mA}$ $V_I = 7\text{ V}$ $T_J = -25\text{ to }85\text{ °C}$	4.8		5.2		
V_I	Operating input voltage	$I_O = 100\text{ mA}$			18	V	
I_O	Output current limit		150	350	425	mA	
ΔV_O	Line regulation	$V_I = 5.7\text{ to }18\text{ V}$ $I_O = 0.5\text{ mA}$		4	30	mV	
ΔV_O	Load regulation	$V_I = 6\text{ V}$ $I_O = 0.5\text{ to }100\text{ mA}$		3	25	mV	
I_d	Quiescent current	$V_I = 6\text{ to }18\text{ V}$ $I_O = 0\text{ mA}$	ON mode		0.5	1	mA
		$V_I = 6\text{ to }18\text{ V}$ $I_O = 100\text{ mA}$			1.5	3	
		$V_I = 6\text{ V}$	OFF mode		50	100	μA
SVR	Supply voltage rejection	$I_O = 5\text{ mA}$ $V_I = 7 \pm 1\text{ V}$	$f = 120\text{ Hz}$		76	dB	
			$f = 1\text{ kHz}$		71		
			$f = 10\text{ kHz}$		60		
eN	Output noise voltage	$B = 10\text{ Hz to }100\text{ kHz}$		50		μV	
V_d	Dropout voltage	$I_O = 100\text{ mA}$		0.2	0.4	V	
		$I_O = 100\text{ mA}$ $T_J = -40\text{ to }125\text{ °C}$			0.5		
V_{IL}	Control input logic low	$T_J = -40\text{ to }125\text{ °C}$			0.8	V	
V_{IH}	Control input logic high	$T_J = -40\text{ to }125\text{ °C}$	2			V	
I_i	Control input current	$V_I = 6\text{ V}$ $V_C = 6\text{ V}$		10		μA	
C_O	Output bypass capacitance	ESR = 0.1 to 10 Ω $I_O = 0\text{ to }100\text{ mA}$	2	10		μF	

Refer to test circuits, $T_J = 25\text{ °C}$, $C_I = 0.1\text{ }\mu\text{F}$, $C_O = 2.2\text{ }\mu\text{F}$ unless otherwise specified.

Table 10: LE80C electrical characteristics

Symbol	Parameter	Test condition	Min.	Typ.	Max.	Unit	
V_O	Output voltage	$I_O = 10\text{ mA}$ $V_I = 10\text{ V}$	7.84	8	8.16	V	
		$I_O = 10\text{ mA}$ $V_I = 10\text{ V}$ $T_J = -25\text{ to }85\text{ °C}$	7.68		8.32		
V_I	Operating input voltage	$I_O = 100\text{ mA}$			18	V	
I_O	Output current limit		150			mA	
ΔV_O	Line regulation	$V_I = 8.7\text{ to }18\text{ V}$ $I_O = 0.5\text{ mA}$		5	35	mV	
ΔV_O	Load regulation	$V_I = 9\text{ V}$ $I_O = 0.5\text{ to }100\text{ mA}$		3	25	mV	
I_d	Quiescent current	$V_I = 9\text{ to }18\text{ V}$ $I_O = 0\text{ mA}$	ON mode		0.7	1.6	mA
		$V_I = 9\text{ to }18\text{ V}$ $I_O = 100\text{ mA}$			1.7	3.6	
		$V_I = 9\text{ V}$	OFF mode		70	140	μA
SVR	Supply voltage rejection	$I_O = 5\text{ mA}$ $V_I = 10 \pm 1\text{ V}$	$f = 120\text{ Hz}$		72		dB
			$f = 1\text{ kHz}$		66		
			$f = 10\text{ kHz}$		57		
eN	Output noise voltage	$B = 10\text{ Hz to }100\text{ kHz}$		50		μV	
V_d	Dropout voltage	$I_O = 100\text{ mA}$		0.2	0.4	V	
		$I_O = 100\text{ mA}$ $T_J = -40\text{ to }125\text{ °C}$			0.5		
V_{IL}	Control input logic low	$T_J = -40\text{ to }125\text{ °C}$			0.8	V	
V_{IH}	Control input logic high	$T_J = -40\text{ to }125\text{ °C}$	2			V	
I_i	Control input current	$V_I = 9\text{ V}$ $V_C = 6\text{ V}$		10		μA	
C_O	Output bypass capacitance	ESR = 0.1 to 10 Ω $I_O = 0\text{ to }100\text{ mA}$	2	10		μF	

5 Typical performance characteristics

Unless otherwise specified, $V_{O(NOM)} = 3.3\text{ V}$.

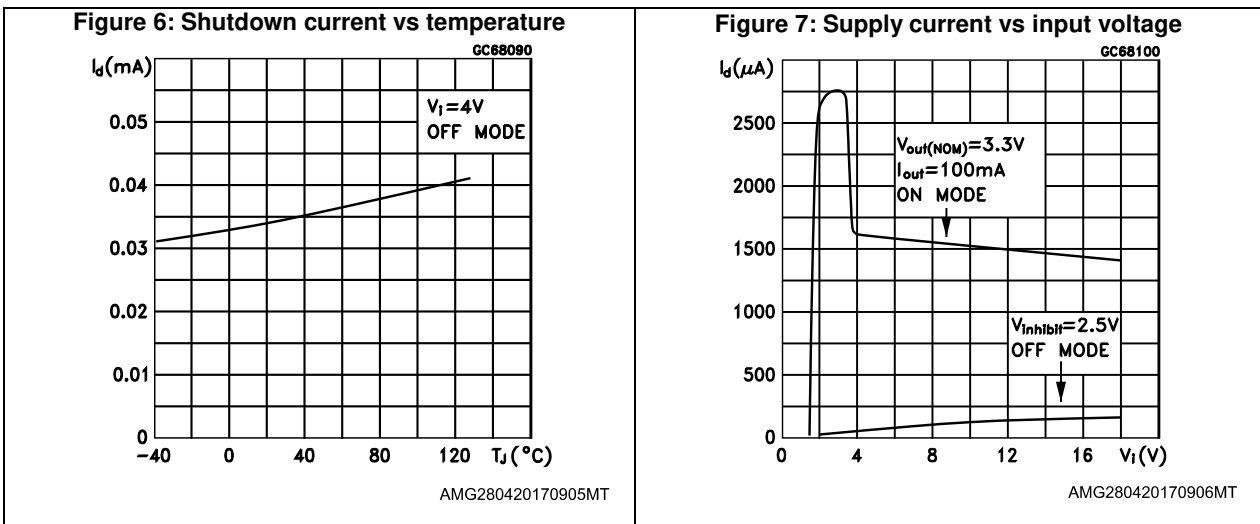
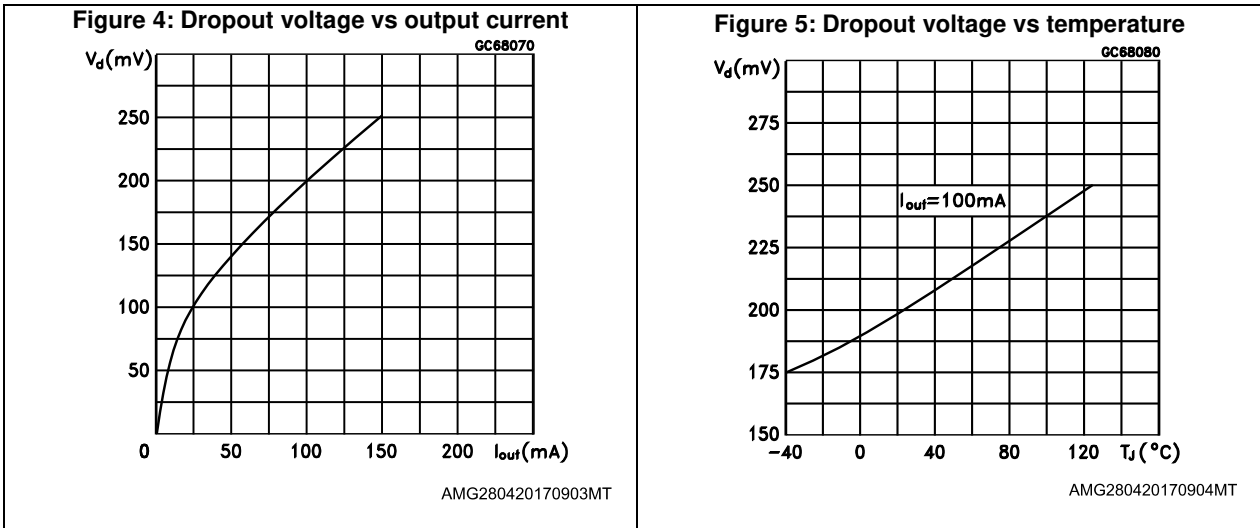

Figure 8: Short-circuit current vs dropout voltage

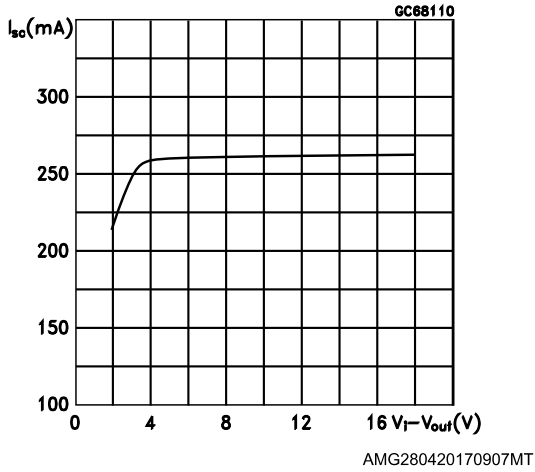

Figure 9: SVR vs frequency

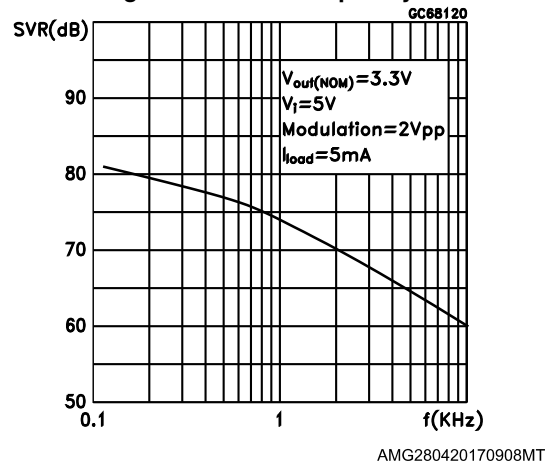

Figure 10: Logic-controlled precision 3.3/5.0 V selectable output

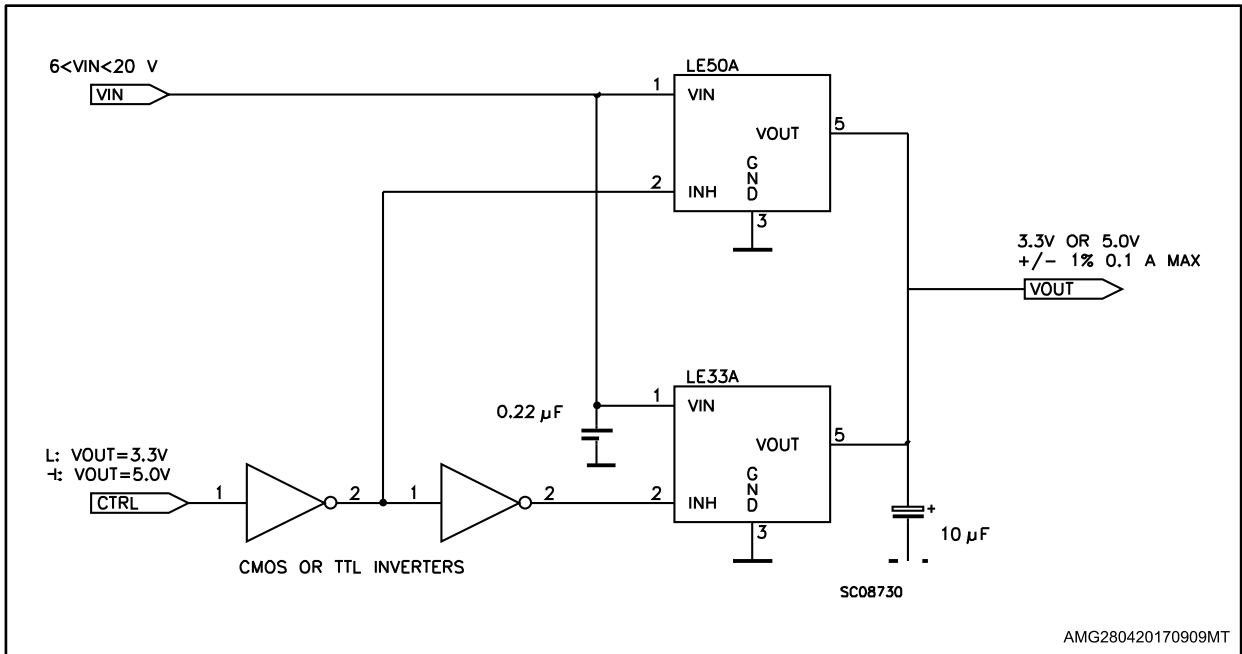

Figure 11: Sequential multi-output supply

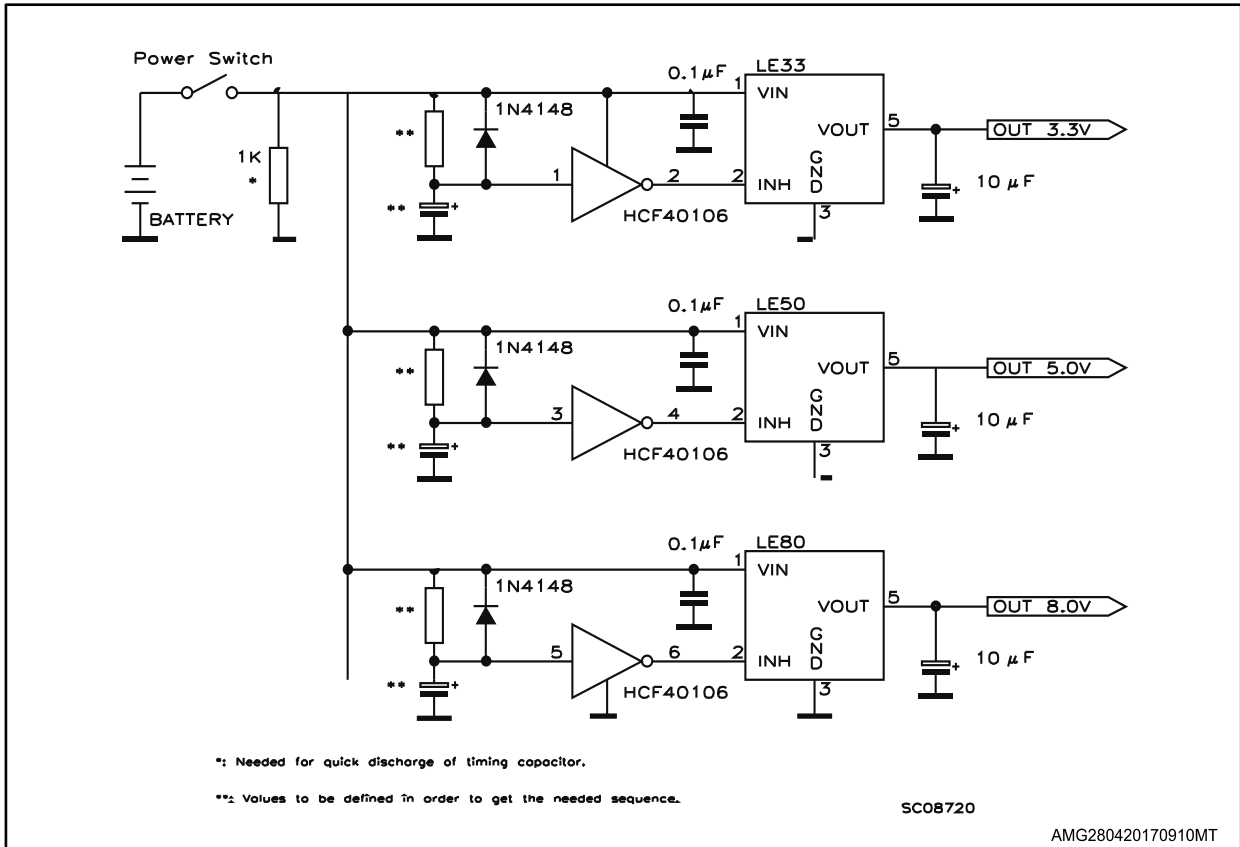
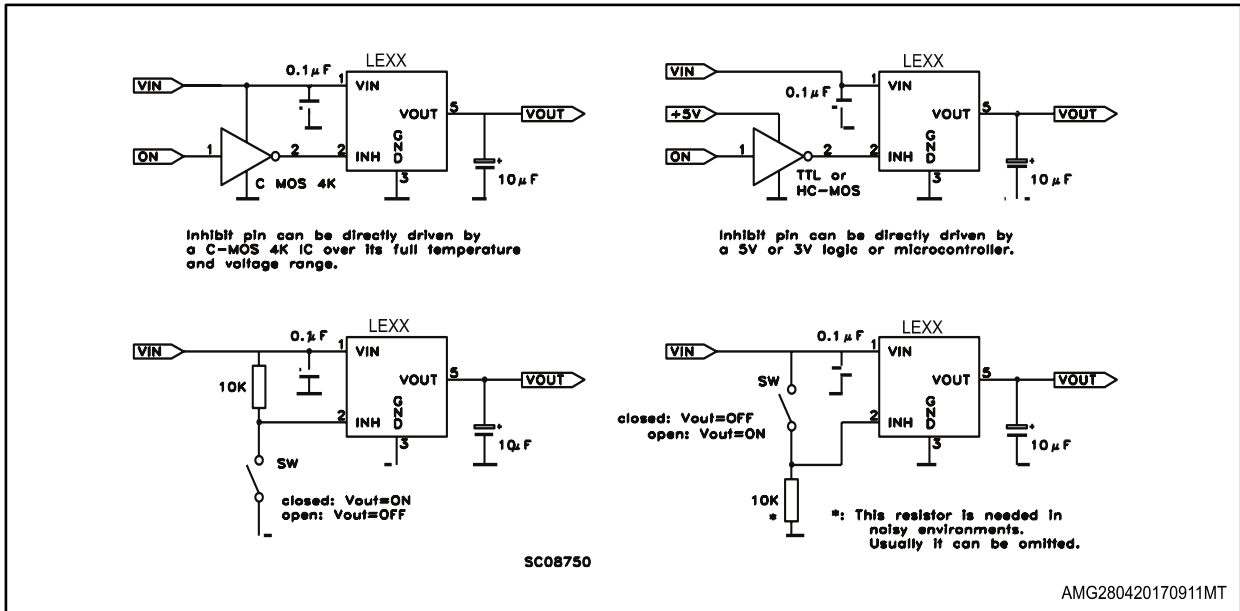

Figure 12: Basic inhibit functions



6 Package information

In order to meet environmental requirements, ST offers these devices in different grades of ECOPACK® packages, depending on their level of environmental compliance. ECOPACK® specifications, grade definitions and product status are available at: www.st.com. ECOPACK® is an ST trademark.

6.1 SO-8 package information

Figure 13: SO-8 package outline

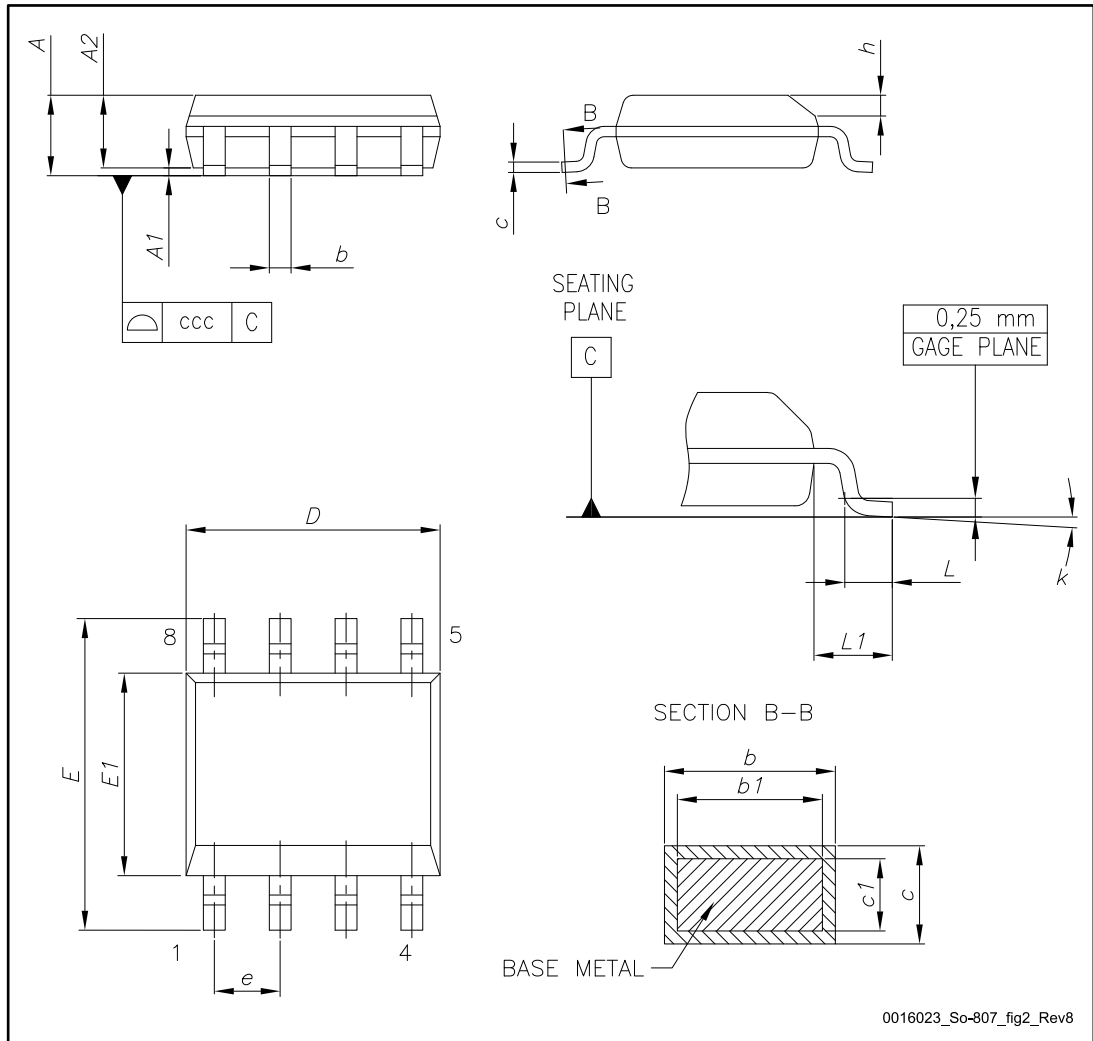
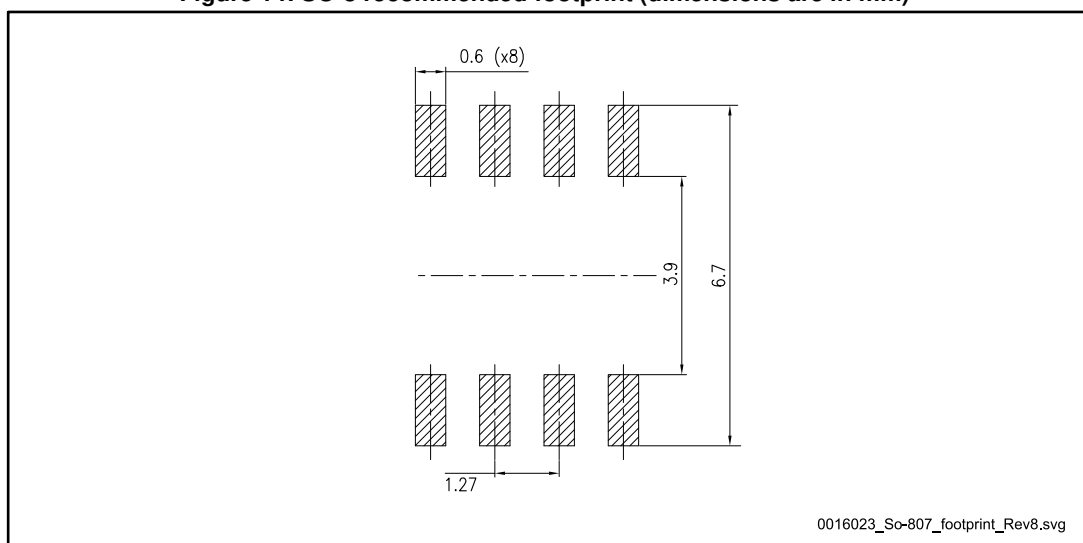

Table 11: SO-8 mechanical data

Dim.	mm		
	Min.	Typ.	Max.
A			1.75
A1	0.10		0.25
A2	1.25		
b	0.31		0.51
b1	0.28		0.48
c	0.10		0.25
c1	0.10		0.23
D	4.80	4.90	5.00
E	5.80	6.00	6.20
E1	3.80	3.90	4.00
e		1.27	
h	0.25		0.50
L	0.40		1.27
L1		1.04	
L2		0.25	
k	0°		8°
ccc			0.10

Figure 14: SO-8 recommended footprint (dimensions are in mm)



6.2 SO-8 packing information

Figure 15: SO-8 tape and reel dimensions

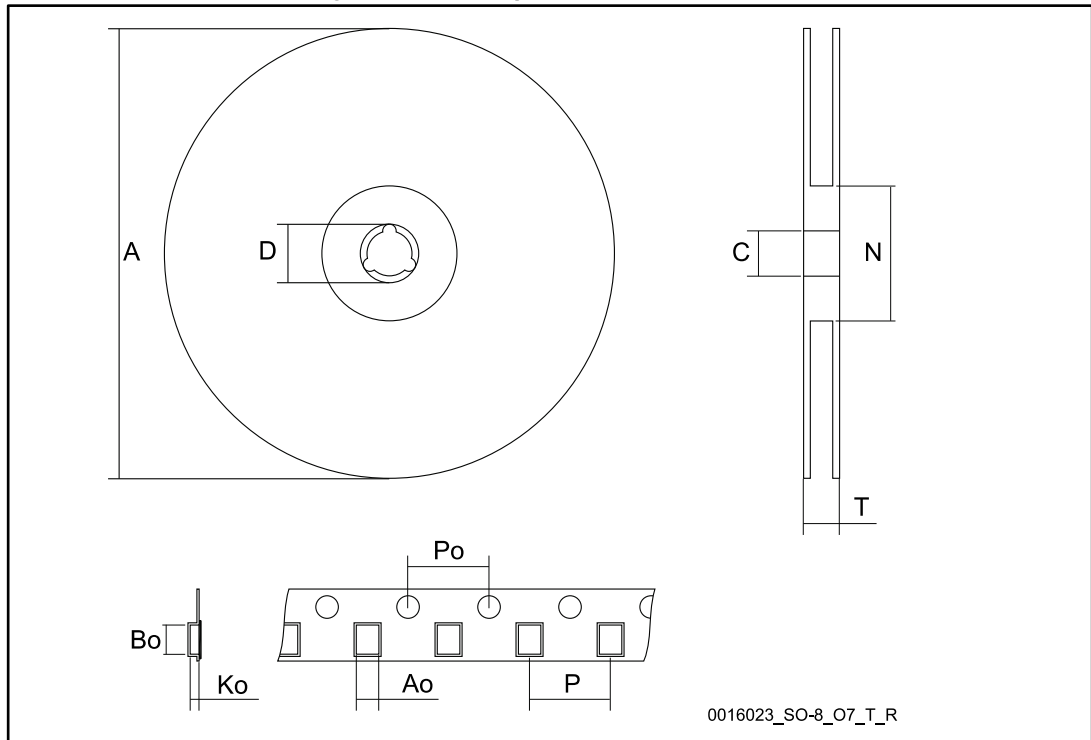

Table 12: SO-8 tape and reel mechanical data

Dim.	mm		
	Min.	Typ.	Max.
A			330
C	12.8		13.2
D	20.2		
N	60		
T			22.4
Ao	8.1		8.5
Bo	5.5		5.9
Ko	2.1		2.3
Po	3.9		4.1
P	7.9		8.1

6.3 TO-92 packing information

Figure 16: TO-92 tape and reel outline

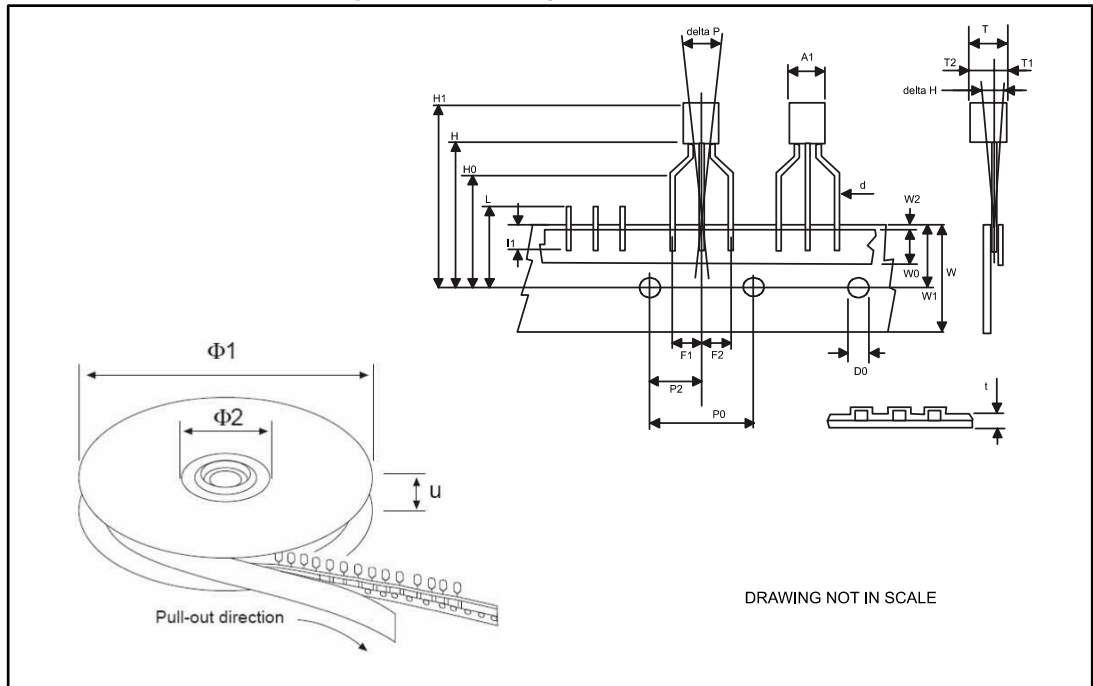

Table 13: TO-92 tape and reel mechanical data

Dim.	mm		
	Min.	Typ.	Max.
A1			4.80
T			3.80
T1			1.60
T2			2.30
d	0.45	0.47	0.48
P0	12.50	12.70	12.90
P2	5.65	6.35	7.05
F1, F2	2.40	2.50	2.94
F3	4.98	5.08	5.48
delta H	-2.00		2.00
W	17.50	18.00	19.00
W0	5.5	6.00	6.5
W1	8.50	9.00	9.25
W2			0.50
H		18.50	21
H3	0.5	1	2
H0	15.50	16.00	18.8
H1		25.0	27.0
D0	3.80	4.00	4.20
t			0.90
L			11.00
l1	3.00		
delta P	-1.00		1.00
Ø1	352	355	358
Ø2	28	30	32
u	44	47	50

6.4 TO-92 Ammopak packing information

Figure 17: TO-92 Ammopak tape and reel outline

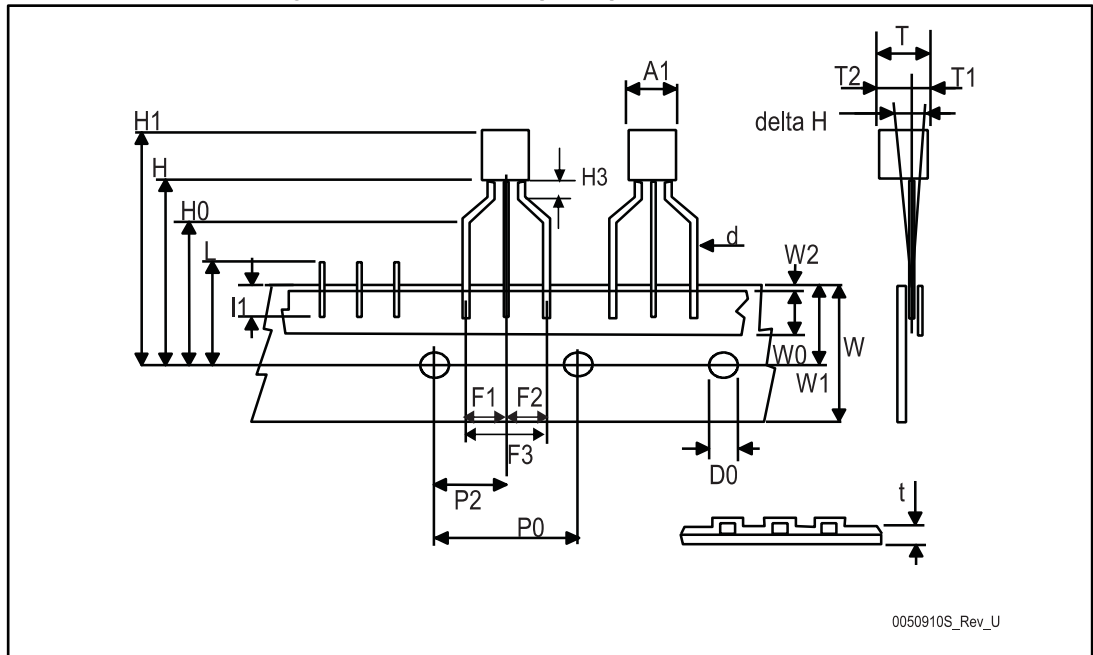

Table 14: TO-92 Ammopak tape and reel mechanical data

Dim.	mm		
	Min.	Typ.	Max.
A1			4.80
T			3.80
T1			1.60
T2			2.30
d	0.45	0.47	0.48
P0	12.50	12.70	12.90
P2	5.65	6.35	7.05
F1, F2	2.40	2.50	2.94
F3	4.98	5.08	5.48
delta H	-2.00		2.00
W	17.50	18.00	19.00
W0	5.5	6.00	6.5
W1	8.50	9.00	9.25
W2			0.50
H		18.50	21
H3	0.5	1	2
H0	15.50	16.00	18.8
H1		25.0	27.0
D0	3.80	4.00	4.20
t			0.90
L			11.00
I1	3.00		
delta P	-1.00		1.00

7 Revision history

Table 15: Document revision history

Date	Revision	Changes
09-Jul-2004	6	lo typ. and max. are changed in tab. 24 and 25 - pag. 14.
16-Mar-2005	7	Add Tape & Reel for TO-92 - Note on Table 3.
12-Feb-2007	8	Change value T _{OP} on Table 2.
26-Jul-2007	9	Add Table 1 in cover page.
29-Nov-2007	10	Modified: Table 25.
12-Feb-2008	11	Modified: Table 25.
10-Jul-2008	12	Modified: Table 1 and Table 25.
22-May-2012	13	Updated: Table 1 on page 1. Changed: TA in TJ test conditions from table 4 to table 10.
14-Mar-2014	14	Changed the part numbers LExxAB and LExxC to LEXX. Updated the title. Added the ammopack package to the figure in cover page. Updated the Table 1: Device summary. Updated the Description. Updated Figure 3. Changed the title of Figure 6. Updated mechanical data.
03-May-2017	15	Updated <i>Table 1: "Device summary"</i> and <i>Section 6: "Package information"</i> . Minor text changes.

IMPORTANT NOTICE – PLEASE READ CAREFULLY

STMicroelectronics NV and its subsidiaries ("ST") reserve the right to make changes, corrections, enhancements, modifications, and improvements to ST products and/or to this document at any time without notice. Purchasers should obtain the latest relevant information on ST products before placing orders. ST products are sold pursuant to ST's terms and conditions of sale in place at the time of order acknowledgement.

Purchasers are solely responsible for the choice, selection, and use of ST products and ST assumes no liability for application assistance or the design of Purchasers' products.

No license, express or implied, to any intellectual property right is granted by ST herein.

Resale of ST products with provisions different from the information set forth herein shall void any warranty granted by ST for such product.

ST and the ST logo are trademarks of ST. All other product or service names are the property of their respective owners.

Information in this document supersedes and replaces information previously supplied in any prior versions of this document.

© 2017 STMicroelectronics – All rights reserved