

## Features

- Generates clock signals at power-up per user defined custom OTP (One Time Programmable) configuration
- Dynamically configurable via SPI/I2C interface and volatile configuration registers
- Four independently programmable clock generators output any clock rate from 1 kHz to 750 MHz (precision) / 350 MHz (general purpose)
- Precision clock generators output clocks with jitter below 0.7 ps RMS for 10 G PHYs
- General purpose clock generators output a wide range of digital bus clocks
- Operates from a single crystal resonator, clock oscillator or voltage controlled oscillator
- Supports programmable frequency offsets for clock margining; or for use as a digitally controlled oscillator
- Eight LVPECL outputs; max rate 750 MHz
- Four LVCMOS outputs; max rate 177.5 MHz

## Ordering Information

ZL30230GGG	100 Pin LPGA	11mmx11mm Trays
ZL30230GGG2	100 Pin LPGA*	11mmx11mm Trays

\*Pb Free Tin/Silver/Copper

**-40°C to +85°C**

- Eight outputs configurable as LVCMOS at 3.3/2.5/1.8 or 1.5 V, max rate 160 MHz; or LVDS/LVPECL/HCSL, max rate 350 MHz

## Applications

- Timing for NPUs, FPGAs, Ethernet switches and PCIe switches
- Timing for 10 Gigabit CDRs, Rapid-IO, PCIe, Serial MII, Star Fabric, Fibre Channel, XAUI
- Processor clock, Processor bus clock, SDRAM clock, DDR clock

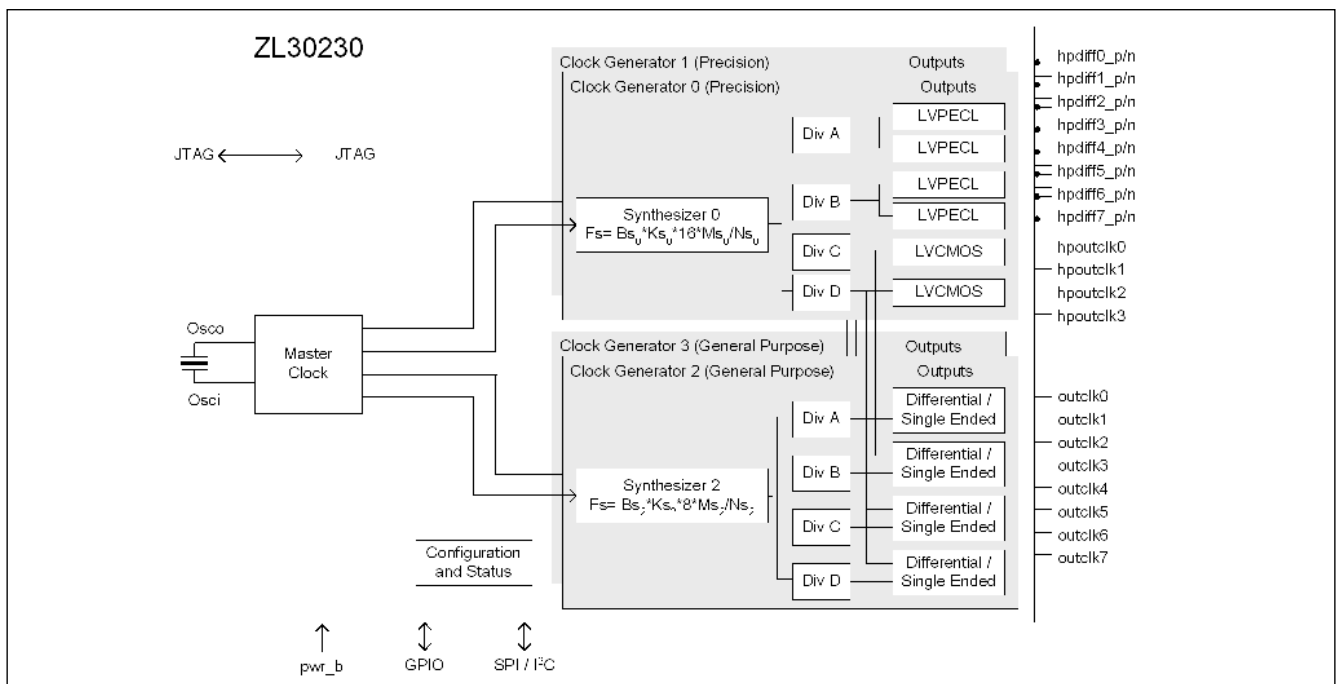

**Figure 1 - Functional Block Diagram**

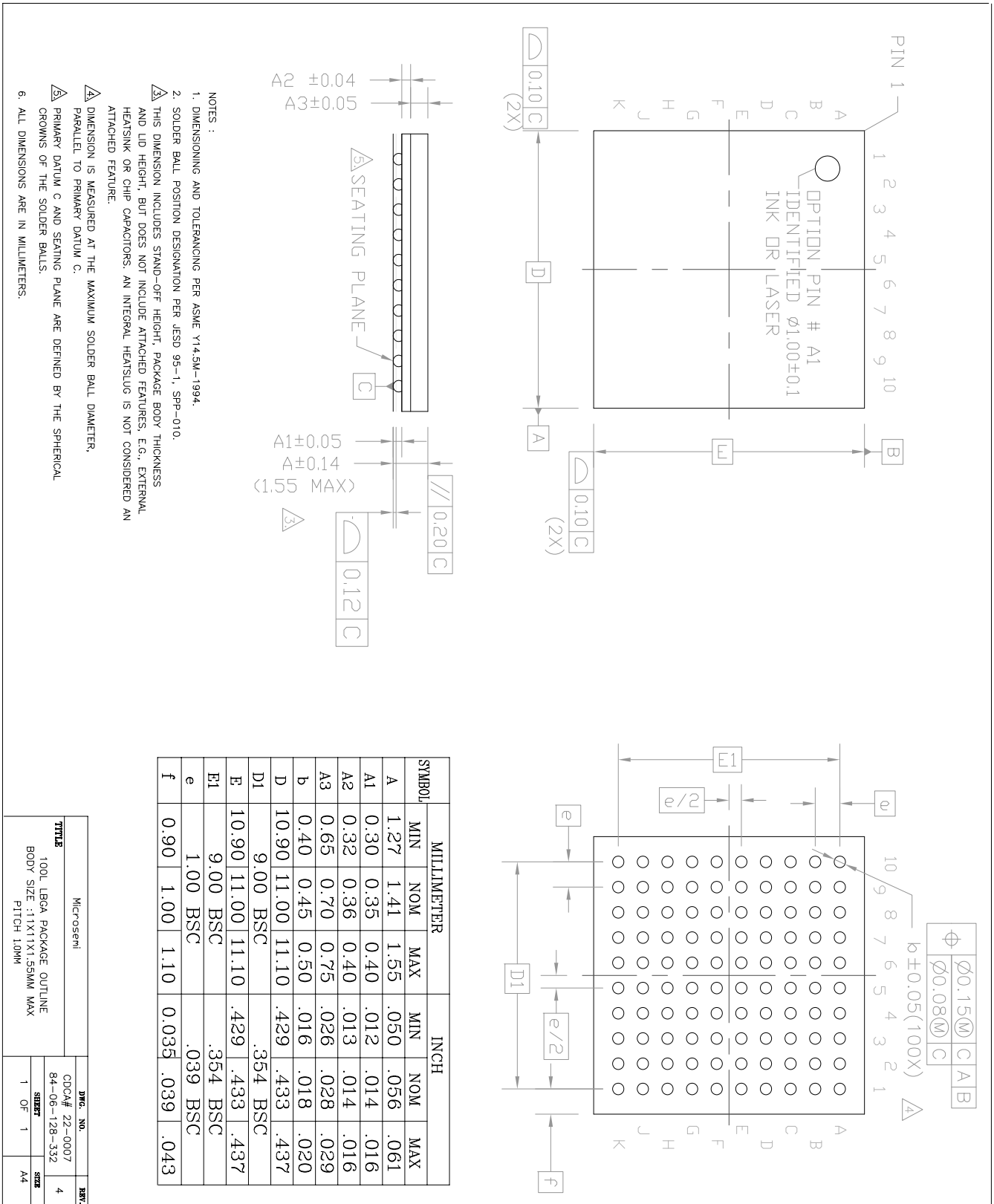
**Mechanical Drawing**

Information relating to products and services furnished herein by Microsemi Corporation or its subsidiaries (collectively "Microsemi") is believed to be reliable. However, Microsemi assumes no liability for errors that may appear in this publication, or for liability otherwise arising from the application or use of any such information, product or service or for any infringement of patents or other intellectual property rights owned by third parties which may result from such application or use. Neither the supply of such information or purchase of product or service conveys any license, either express or implied, under patents or other intellectual property rights owned by Microsemi or licensed from third parties by Microsemi, whatsoever. Purchasers of products are also hereby notified that the use of product in certain ways or in combination with Microsemi, or non-Microsemi furnished goods or services may infringe patents or other intellectual property rights owned by Microsemi.

This publication is issued to provide information only and (unless agreed by Microsemi in writing) may not be used, applied or reproduced for any purpose nor form part of any order or contract nor to be regarded as a representation relating to the products or services concerned. The products, their specifications, services and other information appearing in this publication are subject to change by Microsemi without notice. No warranty or guarantee express or implied is made regarding the capability, performance or suitability of any product or service. Information concerning possible methods of use is provided as a guide only and does not constitute any guarantee that such methods of use will be satisfactory in a specific piece of equipment. It is the user's responsibility to fully determine the performance and suitability of any equipment using such information and to ensure that any publication or data used is up to date and has not been superseded. Manufacturing does not necessarily include testing of all functions or parameters. These products are not suitable for use in any medical and other products whose failure to perform may result in significant injury or death to the user. All products and materials are sold and services provided subject to Microsemi's conditions of sale which are available on request.

**For more information about all Microsemi products  
visit our website at  
[www.microsemi.com](http://www.microsemi.com)**

TECHNICAL DOCUMENTATION – NOT FOR RESALE



**Microsemi Corporate Headquarters**  
One Enterprise, Aliso Viejo CA 92656 USA  
Within the USA: + 1 (949) 380-6100  
Sales: +1 (949) 380-6136  
Fax: +1 (949) 215-4996

Microsemi Corporation (NASDAQ: MSCC) offers a comprehensive portfolio of semiconductor solutions for: aerospace, defense and security; enterprise and communications; and industrial and alternative energy markets. Products include high-performance, high-reliability analog and RF devices, mixed signal and RF integrated circuits, customizable SoCs, FPGAs, and complete subsystems. Microsemi is headquartered in Aliso Viejo, Calif. Learn more at [www.microsemi.com](http://www.microsemi.com).

© 2012 Microsemi Corporation. All rights reserved. Microsemi and the Microsemi logo are trademarks of Microsemi Corporation. All other trademarks and service marks are the property of their respective owners.