

Evaluating the **ADP5350** Battery Management PMIC with Inductive Boost LED and Three LDO Regulators

FEATURES

- Input voltage: 4.0 V to 5.38 V
- Full featured evaluation board for the **ADP5350**
- Evaluation software and installation CD included
- Simple device measurements and demonstrable with
 - A voltage supply
 - A battery or battery simulator
 - Load resistors or an electrical load

EQUIPMENT NEEDED

- USB to I²C dongle **USB-SDP-CABLEZ** (not included in the evaluation kit and must be ordered separately)

SOFTWARE NEEDED

- ADP5350CP-EVALZ** graphic user interface (GUI) software

GENERAL DESCRIPTION

This user guide describes the hardware and software for the evaluation of the **ADP5350CP-EVALZ** evaluation board, and includes detailed schematics and printed circuit board (PCB) layouts.

The **ADP5350** combines one high performance buck regulator for single Li-ion/Li-ion polymer battery charging, a fuel gauge, a highly programmable boost regulator for LED backlight illumination, one ultralow quiescent current low dropout (LDO) regulator, and two general-purpose LDO regulators.

The **ADP5350CP-EVALZ** evaluation board supports an external USB dongle connection and the GUI software allows the user to evaluate the comprehensive functionalities provided by the I²C interface.

The **ADP5350** operates over the -40°C to $+125^{\circ}\text{C}$ junction temperature range and is available in a 32-lead, 5 mm × 5 mm LFCSP package.

Full details on the device are provided in the **ADP5350** data sheet, available from Analog Devices, Inc., which must be consulted in conjunction with this evaluation board user guide.

ADP5350CP-EVALZ EVALUATION BOARD

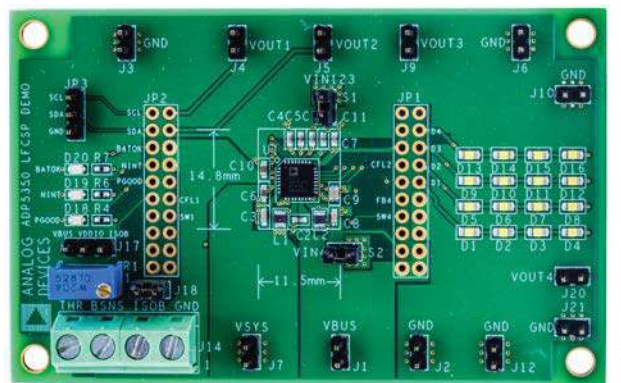

Figure 1.

TABLE OF CONTENTS

Features	1	Direct Register Write and Read.....	7
Equipment Needed.....	1	Fuel Gauge Data Log.....	7
Software Needed.....	1	GUI Troubleshooting.....	8
General Description	1	Using the Evaluation Board	9
ADP5350CP-EVALZ Evaluation Board	1	Powering Up the Evaluation Board	9
Revision History	2	Evaluation Board Measurements	10
Installing the Software	3	Charge Function Evaluation	10
Installing LabVIEW	3	Fuel Gauge Function Evaluation	10
Installing the ADP5350 GUI Software	3	LED and LDO Function Evaluation	10
Installing the Analog Devices SDP Drivers	4	Evaluation Board Schematics and Artwork.....	12
Using ADP5350 GUI Software	5	Ordering Information.....	15
Operating the Board with the GUI	5	Bill of Materials.....	15
Basic Charging Parameter Settings	5	Related Links.....	15
Battery SOC Settings.....	6		
LED Lighting, Boost, and LDO Settings	6		

REVISION HISTORY

2/2017—Revision 0: Initial Version

INSTALLING THE SOFTWARE

The ADP5350CP-EVALZ GUI software allows evaluation of all functions and features of the program registers.

Before starting the software installation, ensure that the ADP5350CP-EVALZ evaluation board is not connected to the USB port of the PC.

INSTALLING LabVIEW

If the PC already has LabVIEW™ installed, this step is not needed.

The application software is a compiled LabVIEW program, which requires LabVIEW 8.5 or later and a run-time engine installed on the PC. Download the LabVIEW run-time engine from the National Instruments website. A LabVIEW 8.5 run-time installation is available on the ADP5350CP-EVALZ installation CD.

INSTALLING THE ADP5350 GUI SOFTWARE

After installation, it may be necessary to reboot the PC to complete the operation.

1. Launch the **Setup.exe** file. The dialog box shown in Figure 2 appears.

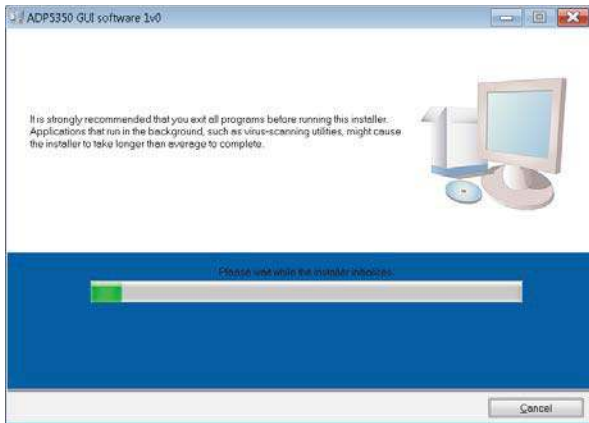

Figure 2. ADP5350 Evaluation Software Setup

2. Click **Next** to install the files to the default destination folder or click **Browse...** to choose a different file (see Figure 3).

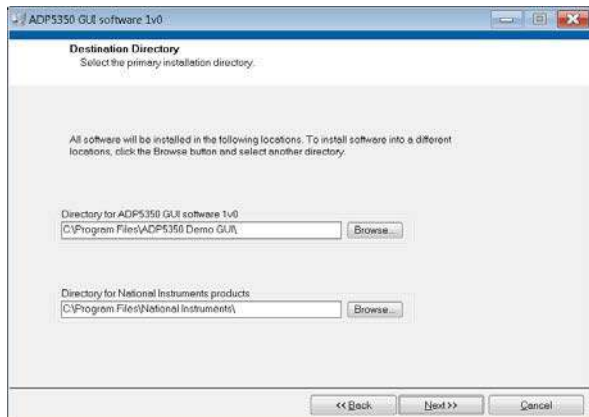

Figure 3. Choose Destination Location

3. Click **Next** to install the program (see Figure 4).

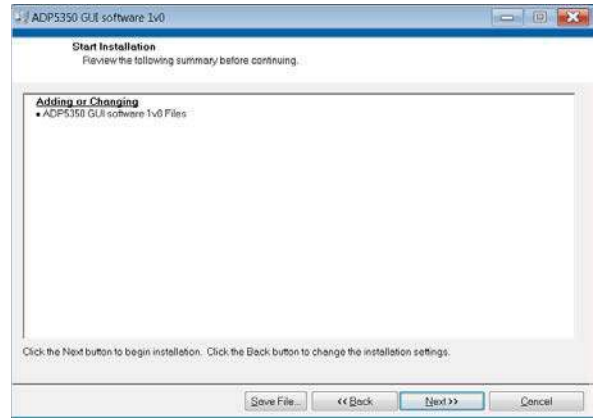

Figure 4. Select Program Folder

4. Click **Finish** to complete the installation (see Figure 5).

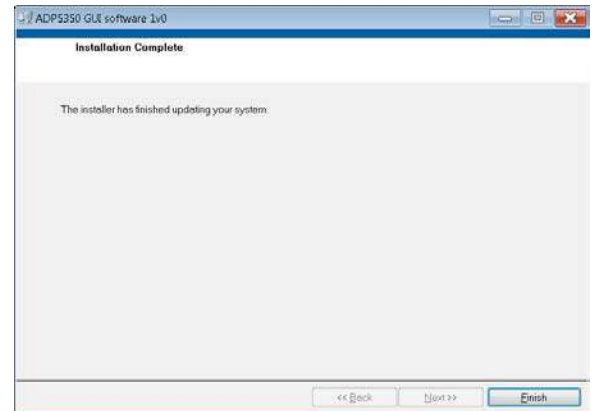

Figure 5. Installation Complete

INSTALLING THE ANALOG DEVICES SDP DRIVERS

To install the Analog Devices system demonstration platform (SDP) drivers, complete the following steps:

1. After installing ADP5350CP-EVALZ GUI software, the installation of the SDP drivers begins.
2. Click **Next** to install the drivers (see Figure 6).



Figure 6. SDP Drivers Setup Wizard

3. Click **Install** after verifying the destination folder. Ensure that the system environment has enough space (see Figure 7).



Figure 7. Verify the Destination Folder

4. Click **Finish** to complete the driver installation (see Figure 8).



Figure 8. Driver Installation Complete

5. To verify that the USB driver is installed properly, click **Start**. Then select **Control Panel > System** and open the **Device Manager** (see Figure 9).

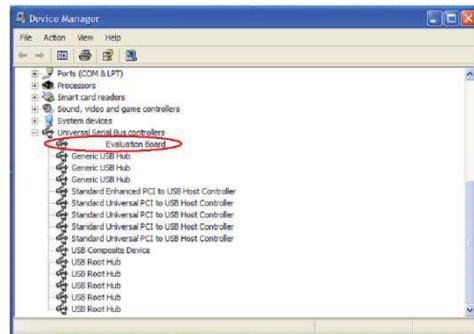

Figure 9. Verify Driver Installation

When the USB dongle is connected to a PC port different from the one used to install the driver, the PC device driver may require that the driver be installed again for that specific port. If this occurs, repeat Step 1 through Step 4.

USING ADP5350 GUI SOFTWARE OPERATING THE BOARD WITH THE GUI

Before running the software,

1. Ensure that the Analog Devices USB to I²C dongle, [USB-SDP-CABLEZ](#), is plugged into the USB port of the computer.
2. Connect a 5 V power supply between the VBUS and GND screw terminals or connect a charged battery between ISOB and GND (see Figure 15).
3. Click **Start > All Programs > ADP5350 GUI 1v0 > ADP5350 GUI**.

The software is then ready to use, as shown in Figure 10. The GUI automatically reads the content of the registers and updates the status of the registers in real time, after the last action.

BASIC CHARGING PARAMETER SETTINGS

After the input power supply is connected and is between 4.0 V and 5.38 V, the [ADP5350](#) begins charging. If the resistance in the THR input corresponds to a battery temperature of between 0°C and 60°C (or to the temperature programmed from I²C) and the battery detection indicates that the battery is connected at the ISOB and BSNS inputs, the [ADP5350](#) enters charging mode.

Charging begins with the default operational parameter settings when EN_CHG is set high. The options under **Charge Parameter Control** on the left side of the **Charge Control** tab can also be selected before the [ADP5350](#) charges.

The **Charge Control** tab includes other options, including **Function Setting**, **Timer Setting**, **Battery Thermistor Control**, and **Interrupt Setting**. The statuses of the charger and battery, fault status, and power-good settings are also indicated on this tab. In addition, when an interrupt occurs, the **Interrupt Message** indication blinks for 5 sec.



Figure 10. ADP5350 GUI Software, Charge Control Tab

BATTERY SOC SETTINGS

Program the battery state of charge (SOC) settings by adjusting the voltage and internal battery resistance, which varies with temperature, in the **Battery SoC** tab (see Figure 11). Enter all battery characterization data, and then click the **Program SoC Curve** button or **Program RBAT** button to write all data to the ADP5350. The GUI then updates the **Battery SoC Curve** and the **RBAT Temperature Compensation** graphs. Other SOC filter parameters, including the **K_RBAT_CHARGE**, **KRBAT_SOC**, **Filter_Charge Limit**, **Filter_Discharge Limit**, and **Filter_Idle Limit** options can be selected in this tab as well.

LED LIGHTING, BOOST, AND LDO SETTINGS

In the **LED&LDO Control** tab, program the boost mode selection, LED lighting functionalities, fade in/out settings, LDO enable and LDO mode settings, and the interrupt (see Figure 12). Before enabling the backlight or the individual LED, the current value must be programmed accordingly. When an LED open fault occurs, verify that the open fault is cleared on the evaluation board and then click **Fault Clear**.

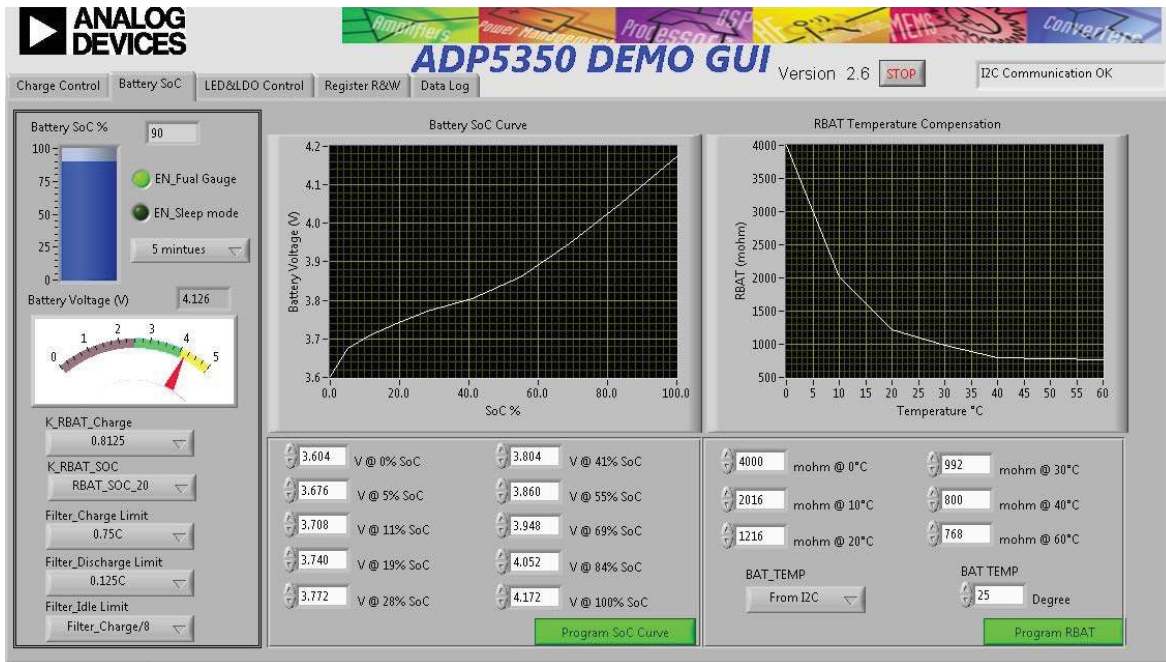

Figure 11. ADP5350 GUI Software, **Battery SoC** Tab



Figure 12. ADP5350 GUI Software, **LED&LDO Control** Tab

DIRECT REGISTER WRITE AND READ

It is possible to read and write the content of each register using the **Register R&W** tab as shown in the GUI (see Figure 13). Clicking **Read All Registers** updates the content of each register to the GUI. Use the **Read/Write a Single Register** controls on the left side of the **Register R/W** tab of the GUI to initiate a single register read or write. Enter the register address in the **Register Address** box. Click **Read** to read the binary data, or click **Write** to write the binary data. Some registers, such as

Register 0x00 and Register 0x01, are read only registers and cannot be overwritten.

Click the **Save** button to save the current parameter setting to a text file. Click the **Load** button to reload the existing setting file from a selected folder.

FUEL GAUGE DATA LOG

In the fuel gauge **Data Log** tab, the battery voltage and SOC data update in the **Battery SoC/Voltage** graph every 1 sec.

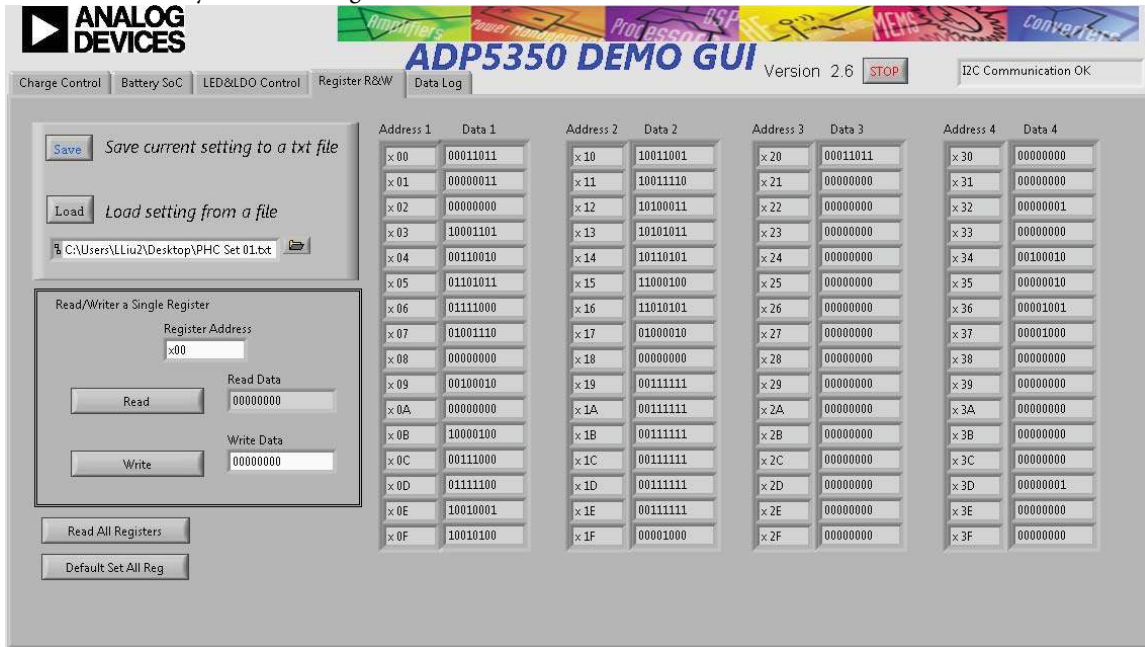

Figure 13. ADP5350 GUI Software, Register R&W Tab

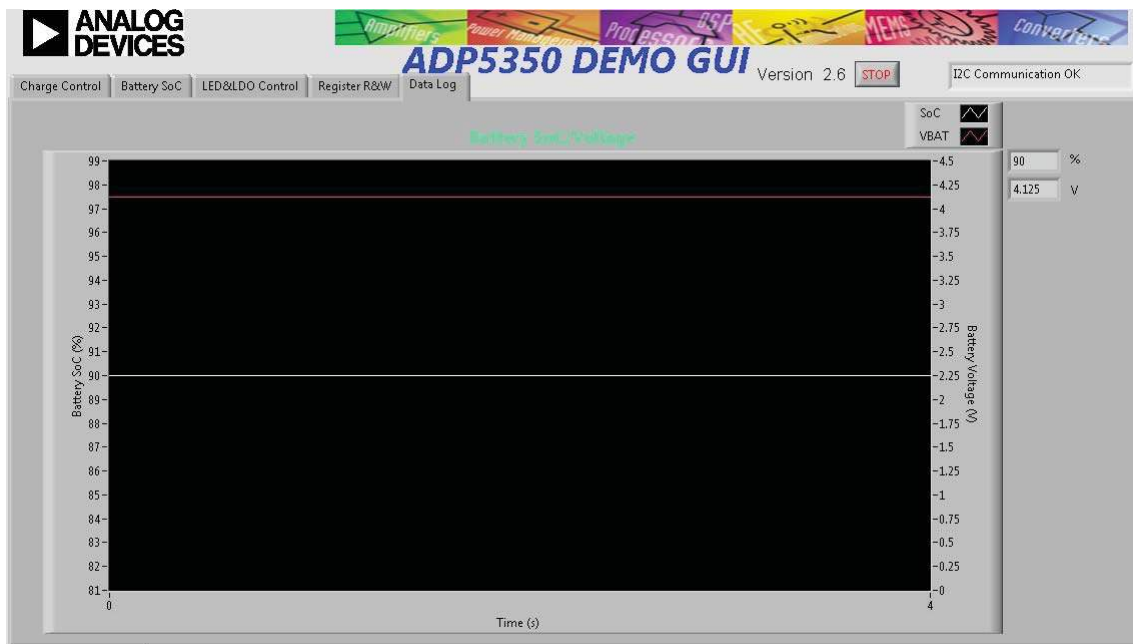

Figure 14. ADP5350 GUI Software, Data Log Tab

GUI TROUBLESHOOTING

If the GUI is not responding and the **Hardware Select** window appears, the reason may relate to the [USB-SDP-CABLEZ](#) not being connected to the computer. If the GUI shows the **I2C Not Response** warning blinking in red in the top right corner of the

window, next to the **STOP** button, this may mean the I²C bus is not detecting the [ADP5350](#). Check that the cable is securely connect to the [ADP5350CP-EVALZ](#) evaluation board and ensure the power is supplied to the device.

USING THE EVALUATION BOARD

POWERING UP THE EVALUATION BOARD

The [ADP5350CP-EVALZ](#) evaluation board is supplied fully assembled and tested. Before applying power to the evaluation board, follow the procedures in this section.

Input Jumpers

Because VIN123 and VIN4 must be connected to VSYS, the input jumpers, S1 and S2, are shunted by default.

Quick Start

A typical test setup follows:

1. Connect the [USB-SDP-CABLEZ](#) cable from the computer USB port to the [ADP5350CP-EVALZ](#) evaluation board.
2. Use a dc power supply to connect VBUS and GND on the [ADP5350CP-EVALZ](#). Set the VBUS supply to 5.0 V, and turn the power on. If evaluation of the charge function is not required, skip this step.
3. Use a charged battery or a battery simulator to connect ISOB and GND.
4. Start the GUI software.

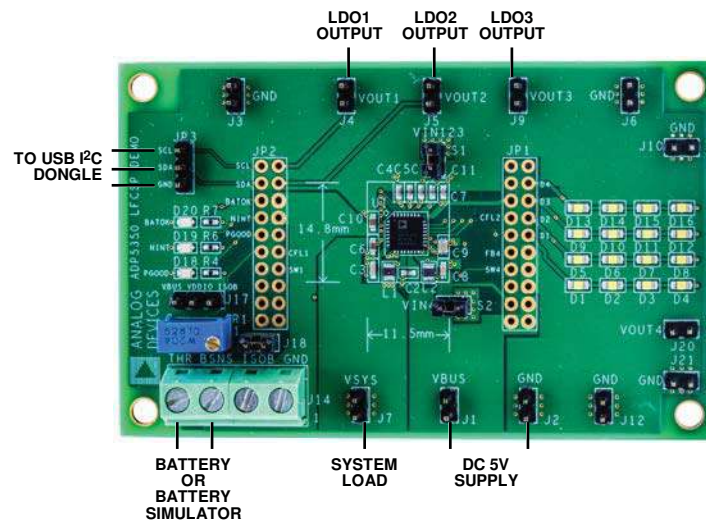

Figure 15. [ADP5350CP-EVALZ](#) LFCSP Board Connection Diagram

15553-015

EVALUATION BOARD MEASUREMENTS

CHARGE FUNCTION EVALUATION

Input Current Limit

The input current-limit function of the ADP5350 can be evaluated in charging mode. To measure the input current limit of the VBUS node across the full programming range of 100 mA to 1500 mA, an additional system load must be connected to the VSYS node.

1. Set the supply voltage of the VBUS node on the ADP5350CP-EVALZ to 5.0 V, populate a charged battery ($V_{BAT} > V_{WEAK}$), or connect a battery simulator to the ISOB node.
2. Use the **ILIM, Input current limit** and **ICHG, Fast charge current** options in the **Charge Control** tab to program the charge current higher than the input current-limit value (see Figure 10).
3. Measure the VBUS node input current and check whether the **VBUS_ILIM** indicator is lit in the **Charger_Status1** section of the **Charge Control** tab (see Figure 10).

A 650 mA charge current into the battery may not be large enough to drive the input current up to the limit when the current limit is programmed to a value of 500 mA or higher.

Connect an additional load to the VSYS node to evaluate values at the higher end of the programming range.

Fast Charge Current

To measure the fast charge current value,

1. Set the supply voltage of the VBUS node on the ADP5350CP-EVALZ to 5.0 V, populate a discharged battery ($V_{BAT} > V_{WEAK}$), or connect a battery simulator to the ISOB node, with its voltage set to 3.7 V.
2. Use the **ILIM, Input current limit** option in the **Charge Control** tab to program the input current limit to the maximum value, 1500 mA.
3. Check that the **THR Status** box shows **Thermistor OK**. Otherwise, the variable resistor, R1, must be tuned until **THR Status** shows **Thermistor OK**. Alternatively, select **From I2C** in the **BAT_TEMP** box, and then program **BAT TEMP** to 25°C in the **Battery SoC** tab (see Figure 11).
4. The default value for the fast charge current is 500 mA. Set the charge current with a range from 25 mA to 650 mA in the **ICHG, Fast charge current** box in the **Charge Control** tab.
5. Click **EN_CHG** under **Function Setting** in the **Charge Control** tab to set the **EN_CHG** bit high, and then measure the input charge current of the battery.

The fast charge current may be reduced due to one of the following conditions:

- The V_{BSNS} level is close to the termination voltage, V_{TRM} (default of 4.200 V) and the device is operating in constant voltage mode.

- The die temperature, T_j , exceeds the isothermal charging temperature, T_{LIM} (typically 115°C).
- The available current from the dc-to-dc converter output of the ADP5350 is limited by the maximum duty cycle (for example, when the I_{CHG} setting is 150 mA and $V_{ISOB} > 3.7$ V).
- The JEITA function is enabled, and the temperature is cool.

Termination Charge Voltage

It is recommended to use a battery simulator to measure the termination charge voltage.

1. Set the supply voltage of the VBUS node on the ADP5350CP-EVALZ to 5.0 V.
2. Set the termination voltage to 4.2 V using the GUI.
3. Sweep V_{ISOB} up until the **Charger Status** box under the **Charger_Status1** section in the GUI shows **Fast Charge (CV Mode)** and the charge current drops to lower than the charge current setting (see Figure 11).
4. Measure the termination voltage between the BSNS and GND nodes.

FUEL GAUGE FUNCTION EVALUATION

The state of charge value that indicates the remaining battery capacity is available by reading the I²C. In the **Battery SoC** tab, the SOC value and the battery voltage are both shown when the **FUEL_GAUGE_ENABLE** bit is enabled. Enabling sleep mode for the fuel gauge places the ADP5350 in very low power consumption mode. Before enabling sleep mode, the battery SOC and internal impedance characterization data must be entered in the lower right portion of the **Battery SoC** tab. Click **Program SoC Curve** and **Program RBAT** to program the data (see Figure 11).

LED AND LDO FUNCTION EVALUATION

LED Backlighting

To configure LED1 to LED3 in the backlight function, follow these steps:

1. Set the supply voltage of the VBUS node on the ADP5350CP-EVALZ to 5.0 V, or connect a charged battery to the ISOB node.
2. Set the backlight current in **IBL_SET** from 0 mA to 20 mA in the **LED&LDO Control** tab (see Figure 12).
3. Set the **BL_LED2** bit and the **BL_LED3** bit high to group LED2 and LED3 for the backlight function.
4. Set the **EN_BL** bit high to enable the grouped backlight function and turn on the LED backlight on the ADP5350CP-EVALZ evaluation board.
5. Set **BL_FO Time** and **BL_FI Time** under the **Fade In/Out and Blink Setting** section in the **LED&LDO Control** tab to program the fade in and fade out feature for the backlight.
6. Set the **EN_BL** bit high and then low to evaluate the backlight fade in and fade out function.

LED Indication

To set LED3 as an individual LED with the blink indication feature, follow these steps:

1. Set the supply voltage of the VBUS node to 5.0 V or connect a charged battery to the ISOB node.
2. Set the LED3 current using the **ILED3 Current** option under the **Backlighting and LED Setting** section of the **LED&LDO Control** tab.
3. Set the **LED3_ON, Blink on Time** and **LED3_OFF, Blink Off Time** options in the **LED&LDO Control** tab (see Figure 12).
4. Set the BL_LED3 bit low, and set the EN_LED3 bit high.

LDO Measurement

The LDO1 by default is always powered on. The output voltage of all three LDO regulators can be programmed in the **LED&LDO Control** tab. The power-on and power-off function of each LDO regulator can be controlled in the **LDO Setting** section via the **VID_LDO1**, **VID_LDO2**, and **VID_LDO3** boxes (see Figure 12).

Connect a load to the LDOx output and measure its voltage and output current.

EVALUATION BOARD SCHEMATICS AND ARTWORK

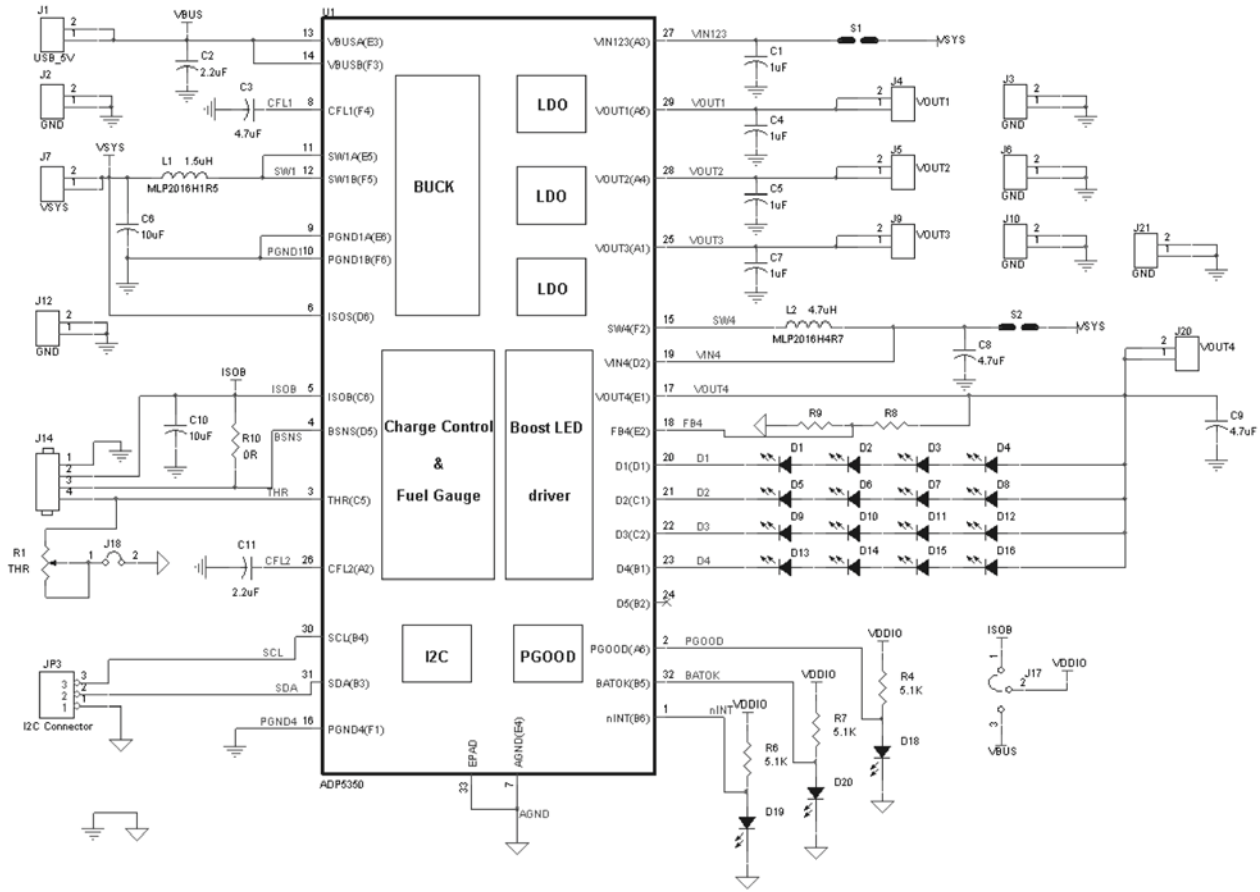

Figure 16. Evaluation Board Schematic of the ADP5350CP-EVALZ Evaluation Board

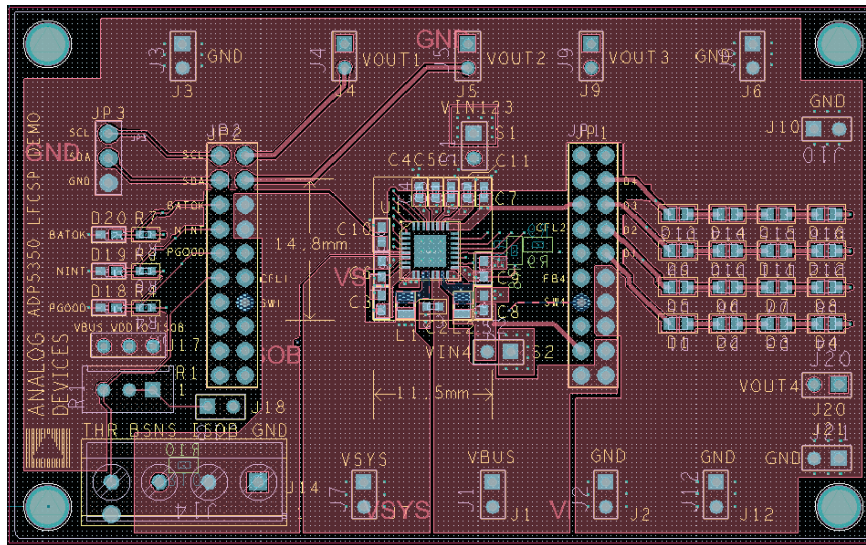

Figure 17. Top Layer, Recommended Layout for the ADP5350CP-EVALZ Evaluation Board

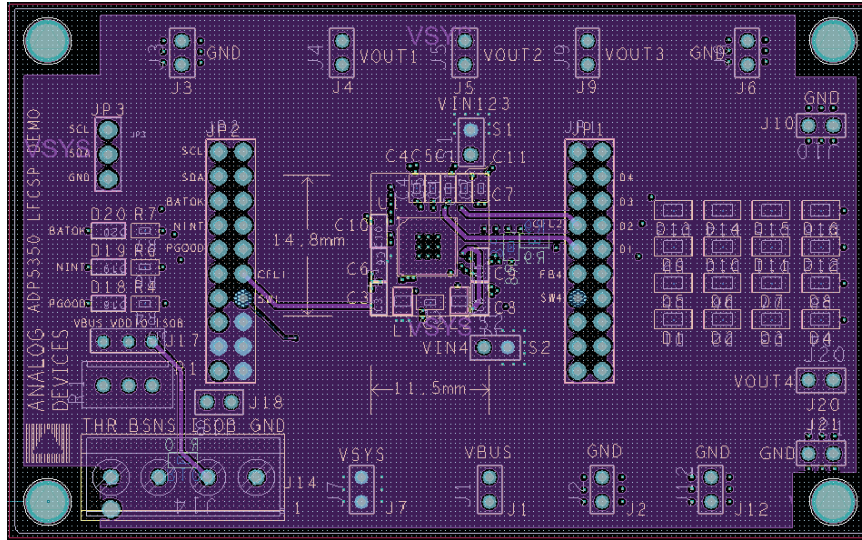

Figure 18. Second Layer, Recommended Layout for the ADP5350CP-EVALZ Evaluation Board

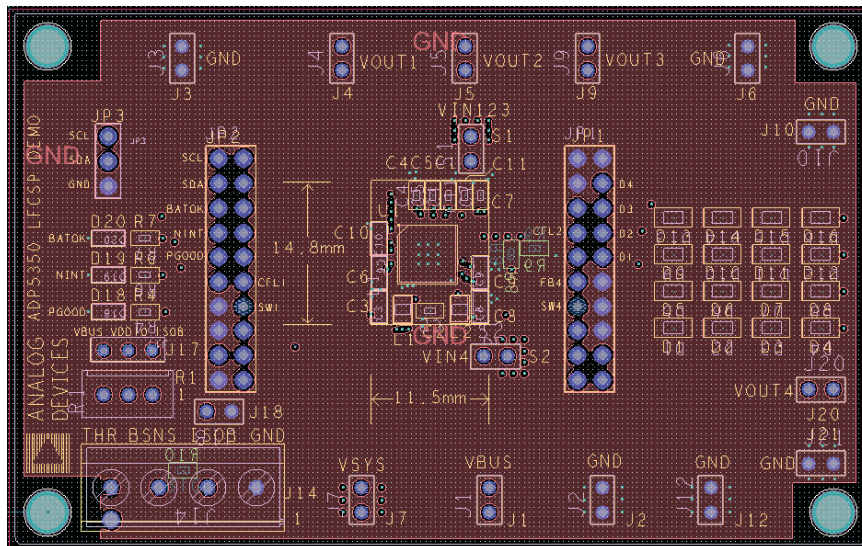

Figure 19. Third Layer, Recommended Layout for the ADP5350CP-EVALZ Evaluation Board

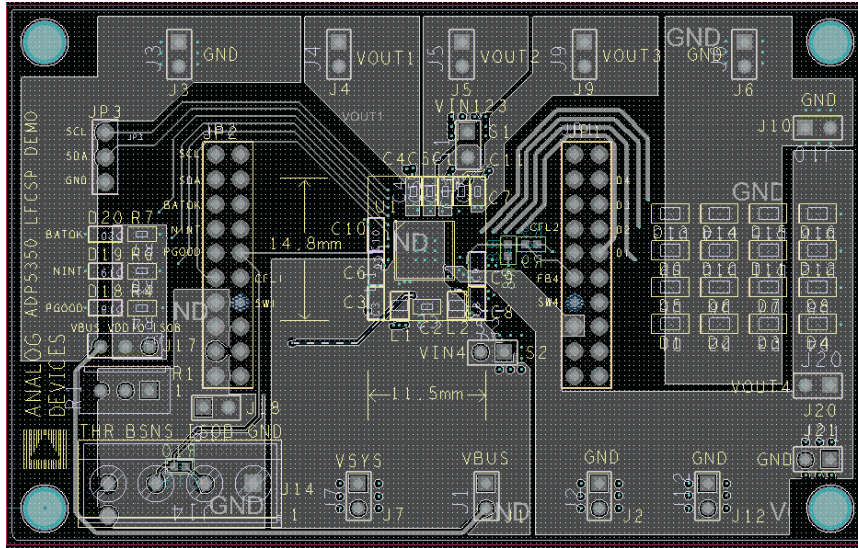

Figure 20. Bottom Layer, Recommended Layout for the ADP5350CP-EVALZ Evaluation Board

ORDERING INFORMATION

BILL OF MATERIALS

Table 1.

Qty.	Reference Designator	Description	Manufacturer	Part Number
1	U1	Battery management, power management IC (PMIC)	Analog Devices	ADP5350
4	C1, C4, C5, C7	Capacitor, multilayer ceramic capacitors (MLCC), 1 μ F 6.3V X5R 0402	Murata	GRM155R60J105KE19D
2	C2, C11	Capacitor, MLCC, 2.2 μ F, 6.3 V, X5R, 0402	Murata	GRM155R60J225KE95D
2	C3, C8	Capacitor, MLCC, 4.7 μ F, 6.3 V, X5R, 0603	Murata	GRM188R60J475KE19D
2	C6, C10	Capacitor, MLCC, 10 μ F, 6.3 V, X5R, 0805	Murata	GRM188R60J106KE47D
1	C9	Capacitor, MLCC, 4.7 μ F, 25 V, X5R, 0603	Murata	GRM21BR61E475KA12
16	D1, D2, D3, D4, D5, D6, D7, D8, D9, D10, D11, D12, D13, D14, D15, D16	LED	Lite-On	LTW-170TK
3	D18, D19, D20	LED	Lite-On	LTST-C192KGKT
1	L1	Inductor, 1.5 μ H	Wurth	74479776215
1	L2	Inductor, 4.7 μ H	Wurth	74479776247A
1	R1	Variable Resistor, 200 k Ω , 0.5W	Bourns	3296W-1-204LF
3	R4, R6, R7	Resistor, 5.1 k Ω , 0402	Panasonic	ERJ-2RKF5101X
1	R8	Resistor, 127 k Ω , 0402	Panasonic	ERJ-2RKF1273X
1	R9	Resistor, 10 k Ω , 0402	Panasonic	ERJ-2RKF1002X
1	R10	Resistor, 0 Ω , 0402	Panasonic	ERJ-2GE0R00X

RELATED LINKS

Resource	Description
ADP5350	Advanced Battery Management PMIC with Inductive Boost LED and Three LDO Regulators



ESD Caution

ESD (electrostatic discharge) sensitive device. Charged devices and circuit boards can discharge without detection. Although this product features patented or proprietary protection circuitry, damage may occur on devices subjected to high energy ESD. Therefore, proper ESD precautions should be taken to avoid performance degradation or loss of functionality.

Legal Terms and Conditions

By using the evaluation board discussed herein (together with any tools, components documentation or support materials, the "Evaluation Board"), you are agreeing to be bound by the terms and conditions set forth below ("Agreement") unless you have purchased the Evaluation Board, in which case the Analog Devices Standard Terms and Conditions of Sale shall govern. Do not use the Evaluation Board until you have read and agreed to the Agreement. Your use of the Evaluation Board shall signify your acceptance of the Agreement. This Agreement is made by and between you ("Customer") and Analog Devices, Inc. ("ADI"), with its principal place of business at One Technology Way, Norwood, MA 02062, USA. Subject to the terms and conditions of the Agreement, ADI hereby grants to Customer a free, limited, personal, temporary, non-exclusive, non-sublicensable, non-transferable license to use the Evaluation Board FOR EVALUATION PURPOSES ONLY. Customer understands and agrees that the Evaluation Board is provided for the sole and exclusive purpose referenced above, and agrees not to use the Evaluation Board for any other purpose. Furthermore, the license granted is expressly made subject to the following additional limitations: Customer shall not (i) rent, lease, display, sell, transfer, assign, sublicense, or distribute the Evaluation Board; and (ii) permit any Third Party to access the Evaluation Board. As used herein, the term "Third Party" includes any entity other than ADI, Customer, their employees, affiliates and in-house consultants. The Evaluation Board is NOT sold to Customer; all rights not expressly granted herein, including ownership of the Evaluation Board, are reserved by ADI. CONFIDENTIALITY. This Agreement and the Evaluation Board shall all be considered the confidential and proprietary information of ADI. Customer may not disclose or transfer any portion of the Evaluation Board to any other party for any reason. Upon discontinuation of use of the Evaluation Board or termination of this Agreement, Customer agrees to promptly return the Evaluation Board to ADI. ADDITIONAL RESTRICTIONS. Customer may not disassemble, decompile or reverse engineer chips on the Evaluation Board. Customer shall inform ADI of any occurred damages or any modifications or alterations it makes to the Evaluation Board, including but not limited to soldering or any other activity that affects the material content of the Evaluation Board. Modifications to the Evaluation Board must comply with applicable law, including but not limited to the RoHS Directive. TERMINATION. ADI may terminate this Agreement at any time upon giving written notice to Customer. Customer agrees to return to ADI the Evaluation Board at that time. LIMITATION OF LIABILITY. THE EVALUATION BOARD PROVIDED HEREUNDER IS PROVIDED "AS IS" AND ADI MAKES NO WARRANTIES OR REPRESENTATIONS OF ANY KIND WITH RESPECT TO IT. ADI SPECIFICALLY DISCLAIMS ANY REPRESENTATIONS, ENDORSEMENTS, GUARANTEES, OR WARRANTIES, EXPRESS OR IMPLIED, RELATED TO THE EVALUATION BOARD INCLUDING, BUT NOT LIMITED TO, THE IMPLIED WARRANTY OF MERCHANTABILITY, TITLE, FITNESS FOR A PARTICULAR PURPOSE OR NON-INFRINGEMENT OF INTELLECTUAL PROPERTY RIGHTS. IN NO EVENT WILL ADI AND ITS LICENSORS BE LIABLE FOR ANY INCIDENTAL, SPECIAL, INDIRECT, OR CONSEQUENTIAL DAMAGES RESULTING FROM CUSTOMER'S POSSESSION OR USE OF THE EVALUATION BOARD, INCLUDING BUT NOT LIMITED TO LOST PROFITS, DELAY COSTS, LABOR COSTS OR LOSS OF GOODWILL. ADI'S TOTAL LIABILITY FROM ANY AND ALL CAUSES SHALL BE LIMITED TO THE AMOUNT OF ONE HUNDRED US DOLLARS (\$100.00). EXPORT. Customer agrees that it will not directly or indirectly export the Evaluation Board to another country, and that it will comply with all applicable United States federal laws and regulations relating to exports. GOVERNING LAW. This Agreement shall be governed by and construed in accordance with the substantive laws of the Commonwealth of Massachusetts (excluding conflict of law rules). Any legal action regarding this Agreement will be heard in the state or federal courts having jurisdiction in Suffolk County, Massachusetts, and Customer hereby submits to the personal jurisdiction and venue of such courts. The United Nations Convention on Contracts for the International Sale of Goods shall not apply to this Agreement and is expressly disclaimed.

©2017 Analog Devices, Inc. All rights reserved. Trademarks and registered trademarks are the property of their respective owners.
UG15553-0-2/17(0)



www.analog.com