

MATERIALS & SPECIFICATIONS

PART NO.	A29400-025	REV	ECO	DATE	APP
		N	102438	03-16-16	TLM

HOUSING:
ALUMINUM 6061-T6, NICKEL
PLATE PER SAE-AMS-2404

INSULATOR:
LIQUID CRYSTAL POLYMER (LCP)
PER ASTM D5138

CONTACTS:
COPPER ALLOY PER MIL-DTL-
32139, GOLD PLATED PER ASTM
B488, (HARD GOLD) TYPE II
CODE C, CLASS 1.27

TERMINATION:
SOLDER COATED WITH SN63A
PER J-STD-006

CURRENT RATING:
1 AMP MAX PER MIL-DTL-32139

CONTACT RESISTANCE:
71 MILLIOHM MAX (71mV DROP
MAX) @ 1.0 AMPS PER MIL-
DTL-32139

PERFORMANCE:
PRODUCT FAMILY TESTED TO AND
PASSED THE PERFORMANCE
SPECIFICATIONS OF TABLE VIII OF
MIL-DTL-32139

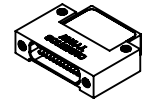
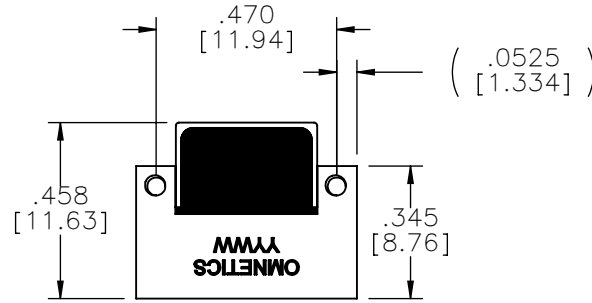

ACTUAL SIZE

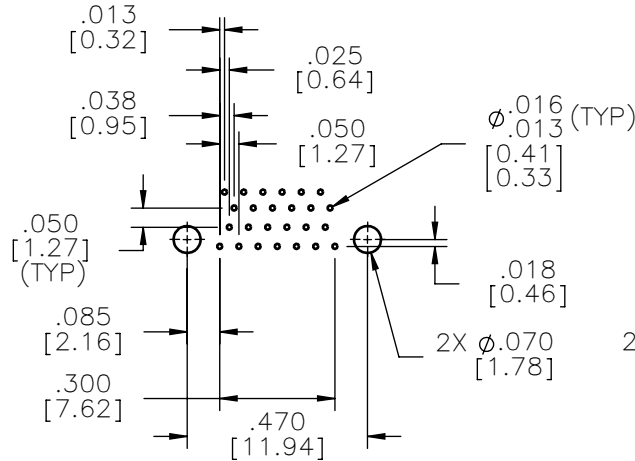
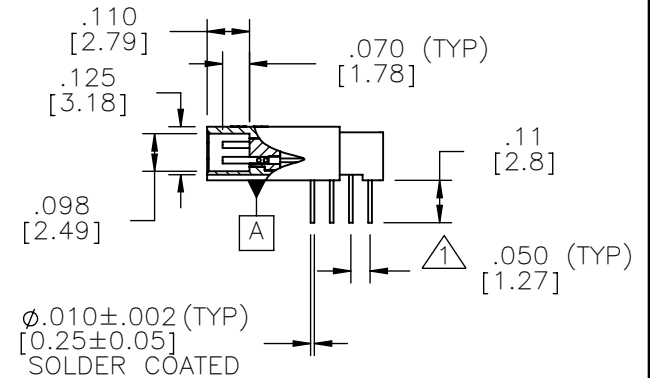
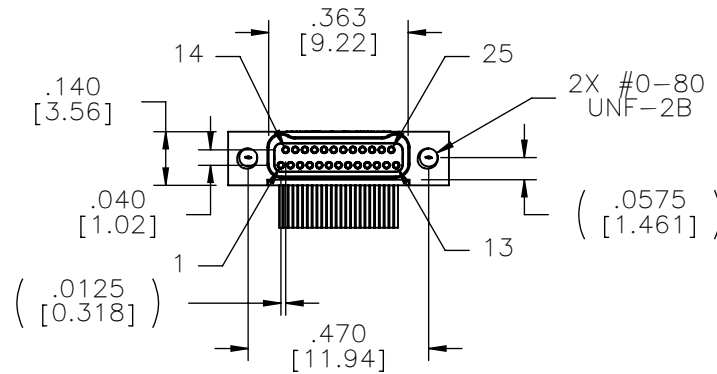

SUGGESTED HOLE PATTERN

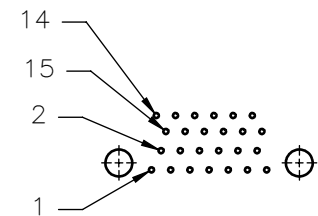
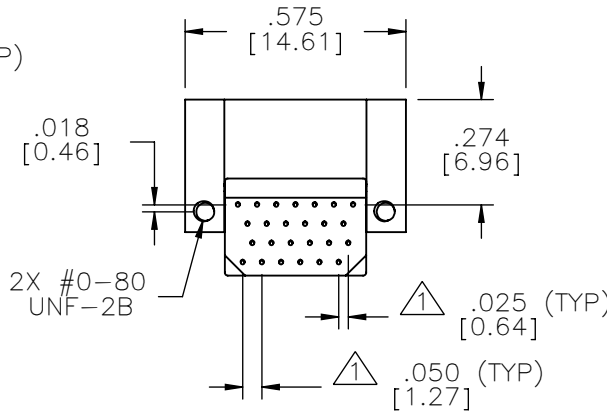

SUGGESTED HOLE PATTERN
PIN OUT

△ TAIL DIMENSIONS APPLY AT PLANE [A]

NOTE:

DIMENSIONS IN [] ARE IN
MILLIMETERS UNLESS
OTHERWISE NOTED AND ARE
FOR REFERENCE ONLY

MATERIALS	THIRD ANGLE
	-TOLERANCES-
	UNLESS OTHERWISE NOTED
	DIMENSIONS IN INCHES
METHODS	2 PL DEC ± .01
	3 PL DEC ± .005
	4 PL DEC ± .0005
	ANGLES ± 1°

THIS DRAWING CONTAINS CONFIDENTIAL AND PROPRIETARY INFORMATION WHICH IS THE PROPERTY OF OMNETICS CONNECTOR CORP. THIS DOCUMENT MAY NOT, IN WHOLE OR IN PART, BE DUPLICATED, OR DISCLOSED FOR ANY PURPOSE, WITHOUT WRITTEN PERMISSION FROM OMNETICS CONNECTOR CORP.

DFTM. SKP	DATE
CHK'D.	DATE
APP'D.	DATE

TITLE:
(25) SOCKET FEMALE
Bi-Lobe® CONNECTOR

OMNETICS
CONNECTOR CORPORATION
7260 COMMERCE CIRCLE EAST
MINNEAPOLIS, MN 55432
WWW.OMNETICS.COM

CAGE CODE	61873
DWG NO.	A29400-025
SHEET 1 OF 1	REV N
SCALE:	2:1