



CY8CKIT-007

PSoC[®] 3 Precision Analog Voltmeter Demo
Kit Guide

Spec. # 001-51794 Rev. *B

Cypress Semiconductor
198 Champion Court
San Jose, CA 95134-1709
Phone (USA): 800.858.1810
Phone (Intl): 408.943.2600
<http://www.cypress.com>

Copyrights

© Cypress Semiconductor Corporation, 2009-2011. The information contained herein is subject to change without notice. Cypress Semiconductor Corporation assumes no responsibility for the use of any circuitry other than circuitry embodied in a Cypress product. Nor does it convey or imply any license under patent or other rights. Cypress products are not warranted nor intended to be used for medical, life support, life saving, critical control or safety applications, unless pursuant to an express written agreement with Cypress. Furthermore, Cypress does not authorize its products for use as critical components in life-support systems where a malfunction or failure may reasonably be expected to result in significant injury to the user. The inclusion of Cypress products in life-support systems application implies that the manufacturer assumes all risk of such use and in doing so indemnifies Cypress against all charges.

Any Source Code (software and/or firmware) is owned by Cypress Semiconductor Corporation (Cypress) and is protected by and subject to worldwide patent protection (United States and foreign), United States copyright laws and international treaty provisions. Cypress hereby grants to licensee a personal, non-exclusive, non-transferable license to copy, use, modify, create derivative works of, and compile the Cypress Source Code and derivative works for the sole purpose of creating custom software and or firmware in support of licensee product to be used only in conjunction with a Cypress integrated circuit as specified in the applicable agreement. Any reproduction, modification, translation, compilation, or representation of this Source Code except as specified above is prohibited without the express written permission of Cypress.

Disclaimer: CYPRESS MAKES NO WARRANTY OF ANY KIND, EXPRESS OR IMPLIED, WITH REGARD TO THIS MATERIAL, INCLUDING, BUT NOT LIMITED TO, THE IMPLIED WARRANTIES OF MERCHANTABILITY AND FITNESS FOR A PARTICULAR PURPOSE. Cypress reserves the right to make changes without further notice to the materials described herein. Cypress does not assume any liability arising out of the application or use of any product or circuit described herein. Cypress does not authorize its products for use as critical components in life-support systems where a malfunction or failure may reasonably be expected to result in significant injury to the user. The inclusion of Cypress' product in a life-support systems application implies that the manufacturer assumes all risk of such use and in doing so indemnifies Cypress against all charges.

Use may be limited by and subject to the applicable Cypress software license agreement.

PSoC Designer™, and PSoC® Creator™ are trademarks and PSoC® is a registered trademark of Cypress Semiconductor Corp. All other trademarks or registered trademarks referenced herein are property of the respective corporations.

Flash Code Protection

Cypress products meet the specifications contained in their particular Cypress PSoC Data Sheets. Cypress believes that its family of PSoC products is one of the most secure families of its kind on the market today, regardless of how they are used. There may be methods, unknown to Cypress, that can breach the code protection features. Any of these methods, to our knowledge, would be dishonest and possibly illegal. Neither Cypress nor any other semiconductor manufacturer can guarantee the security of their code. Code protection does not mean that we are guaranteeing the product as "unbreakable."

Cypress is willing to work with the customer who is concerned about the integrity of their code. Code protection is constantly evolving. We at Cypress are committed to continuously improving the code protection features of our products.

Contents



1. Introduction	5
1.1 Kit Contents	5
1.2 CD Installation	5
1.3 PSoC Creator	6
1.4 Example Projects	6
1.5 Document Revision History	7
1.6 Documentation Conventions	7
2. Kit Operation	9
2.1 Power Supply	10
2.2 Voltmeter Measurement	10
2.3 Thermocouple	10
3. Hardware	11
3.1 System Block Diagram and Theory of System Operation	11
3.2 Functional Description – All Components	12
3.3 Button and Connector Functions	13
3.4 Power Supply Options	13
4. Firmware	15
4.1 ADC_DeISig	17
4.2 Analog Multiplexer (InputSourceMux)	18
4.3 Opamp	19
4.4 Segment LCD	20
4.5 CapSense	21
A. Appendix	25
A.1 Schematic	25
A.2 Bill of Materials	26
A.3 PCB Layout and Silkscreen	29
A.4 Assembly Drawing	31

1. Introduction



The CY8CKIT-007 PSoC[®] 3 Precision Analog Voltmeter Demo Kit showcases PSoC's 20-bit Delta Sigma Analog to Digital Converter. This kit contains a PSoC CY8C3866, which is connected to voltmeter leads and a precision reference (in this case a thermocouple).

The kit has the following features:

- 20-Bit High Precision Delta Sigma ADC.
- Input DC Voltages Range from -30V to 30V.
- Type K Thermocouple.
- CapSense Button to Select Between Sources: Voltmeter Leads or Thermocouple.

The kit operates from a pack of two AA batteries (which is included in the kit). The measurement is displayed on the segment LCD, which is directly driven by the PSoC device. PSoC provides superior integration and high precision analog for the most demanding customer applications.

The CY8CKIT-007 PSoC 3 Precision Analog Voltmeter Demo Kit is based on the PSoC 3 family of devices. PSoC is a Programmable System-on-Chip platform for 8-, 16-, and 32-bit applications and combines user programmable 20-bit precision analog and digital logic with a high-performance 8051 single cycle per instruction pipelined processor achieving 10X the performance of previous 8051 processors. With this PSoC you can create the exact combination of peripherals and integrated proprietary IP to meet the needs of their applications. You are no longer constrained by what you can find in a catalog.

1.1 Kit Contents

- Voltmeter Board (with Thermocouple)
- Resource CD
- Mini-Hook Leads for Voltmeter Measurement
- Pack for powering the Voltmeter (includes two AA batteries and USB mini-B connector)
- Quick Start Guide

1.2 CD Installation

To install the Voltmeter kit software, do as follows:

1. Insert the Voltmeter Kit CD into the CD drive of your PC. The CD is designed to auto-run and **Voltmeter Kit** menu appears.
2. The installation allows user to install the following software:
 - PSoC Creator™
 - PSoC Programmer
 - Documentation for the Voltmeter Kit
 - Firmware for the Voltmeter Kit
 - Hardware for the Voltmeter Kit

Note: If auto-run does not execute, do double click the *cyautorun.exe* on the root of the CD. You can also browse the documents inside the **Voltmeter kit** folder with Windows Explorer.

Figure 1-1. Double Click cyautorun.exe

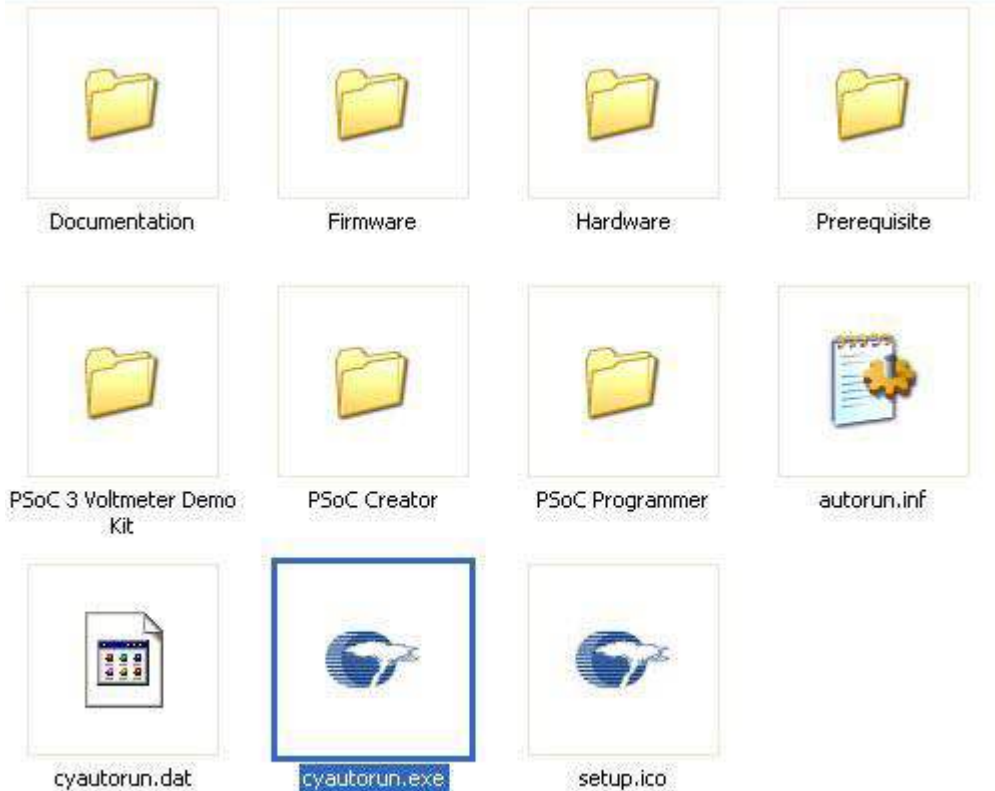

1.3 PSoC Creator

Cypress's PSoC Creator software is a state-of-the-art, easy-to-use software development IDE that introduces a game-changing, hardware, and software co-design environment based on classical schematic entry—a revolutionary embedded design methodology.

With PSoC Creator, you can:

- Automatically place and route select components and integrate simple glue logic normally residing in discrete muxes or 22V10s
- Trade-off hardware and software design considerations allowing you to focus on what matters, getting to market fast

PSoC Creator also enables you to tap into an entire tools ecosystem, with integrated compiler tool chains, RTOS solutions, and top production programmers to support both PSoC 3 and PSoC 5.

1.4 Example Projects

This kit is designed as a demonstration kit only. It is not designed to have detailed source code guidance. If you desire to learn more about the voltmeter firmware project or the code, do refer to kit CD.

1.5 Document Revision History

Table 1-1. Revision History

Revision	PDF Creation Date	Origin of Change	Description of Change
**	09/15/2009	AESA	New Kit Guide.
*A	02/01/2010	AESA	Updated Section 4.2 and Chapter 4 Images.
*B	01/05/2011	SASH	Updated images in Section 4.1 to Section 4.4. Modified text in Section 4.3.

1.6 Documentation Conventions

Table 1-2. Document Conventions for Guides

Convention	Usage
Courier New	Displays file locations, user entered text, and source code: C:\...cd\icc\
<i>Italics</i>	Displays file names and reference documentation: Read about the <i>sourcefile.hex</i> file in the <i>PSoC Designer User Guide</i> .
[Bracketed, Bold]	Displays keyboard commands in procedures: [Enter] or [Ctrl] [C]
File > Open	Represents menu paths: File > Open > New Project
Bold	Displays commands, menu paths, and icon names in procedures: Click the File icon and then click Open .
Times New Roman	Displays an equation: $2 + 2 = 4$
Text in gray boxes	Describes Cautions or unique functionality of the product.



2. Kit Operation



The CY8CKIT-007 PSoC 3 Precision Analog Voltmeter Demo Kit demonstrates the precision of the CY8C3866 Delta-Sigma 20-bit ADC. It measures an external voltage with range of -30V to +30V. This kit can also measure the voltage of a thermocouple sensor generated by the different temperature of the two terminals. The measurement is displayed on the LCD continuously at a rate of 2.08 Hz. The thermocouple is used for precision reference and showcases the 20-bit resolution of the ADC. It does not measure temperature. Users can implement temperature measurement depending on their design-specific requirements.

Figure 2-1. CY8CKIT-007 PSoC 3 Precision Analog Voltmeter Demo Kit

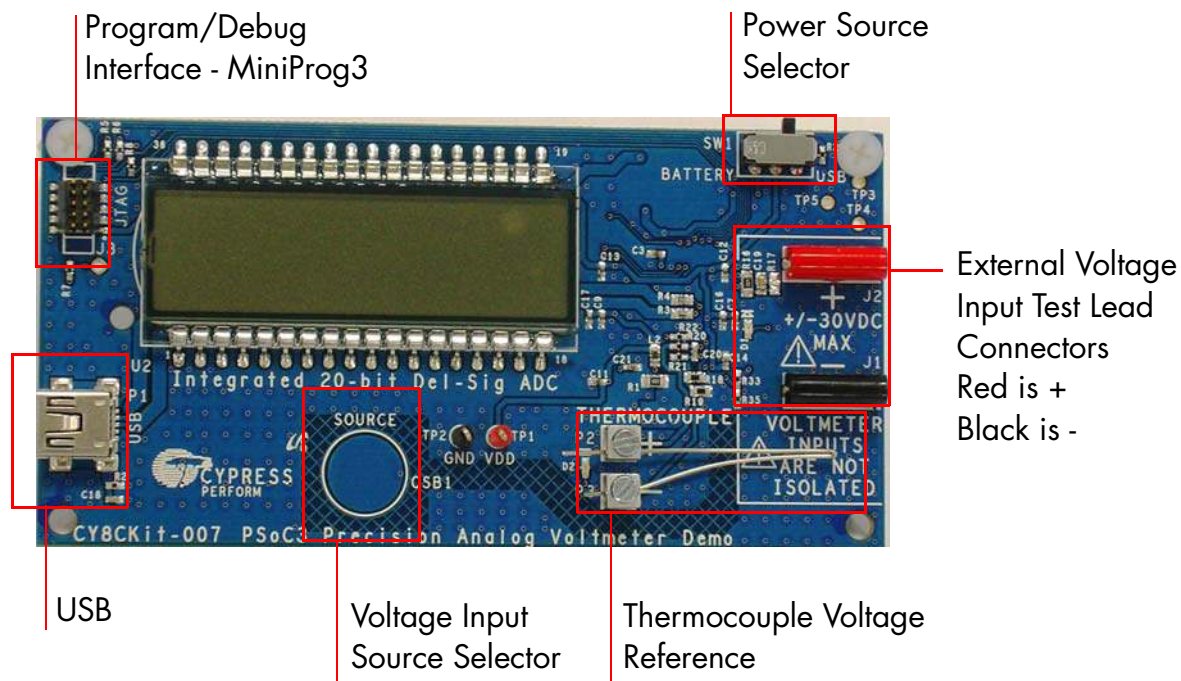

2.1 Power Supply

The Voltmeter kit is powered through a USB connector from a pack of two AA batteries.

How to connect:

1. Switch SW1 to the USB position (right).
2. Connect the USB mini-B connector attached to the AA battery pack to the USB female connector on the board.

Refer to [3.4 Power Supply Options](#) for different power supply options.

2.2 Voltmeter Measurement

1. After you connect the power, D1 LED is ON. The LCD displays the firmware version number briefly and the voltmeter measurement begins.
2. To reset the Voltmeter reading to ZERO, touch and hold the SOURCE button CSB1 for more than 2 seconds.

2.3 Thermocouple

1. To switch the voltage source between the Voltmeter and Thermocouple, touch and release the SOURCE button CSB1 quickly. When thermocouple is selected, D2 LED is ON. The thermocouple measurement is not in temperature unit. It provides high resolution relative voltage measurement on the thermocouple output.
2. To reset the offset of the thermocouple reading to ZERO, touch and hold the SOURCE button CSB1 for more than 2 seconds. You touch the tip of the thermocouple with a hot object or hand. The display shows the change of the temperature in a relative high resolution in voltage.

3. Hardware



3.1 System Block Diagram and Theory of System Operation

A single CapSense® button is used to select the signal source. The LEDs D1 and D2 are used to indicate the selected signal source between the Voltmeter and Thermocouple respectively. CY8C3866 drives the LCD segment directly without external driver. The voltmeter or thermocouple data is displayed on a 8 digit LCD, which is driven directly by the CY8C3866 itself.

Figure 3-1. Voltmeter Kit Block Diagram

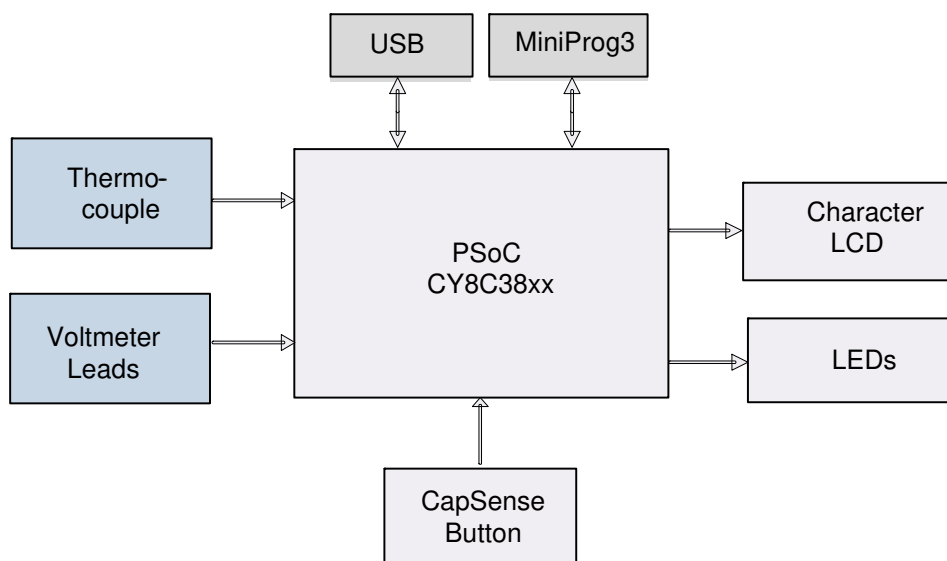

In the voltmeter input, a resistor network is used to scale down the voltage to suitable input voltage for the Delta Sigma ADC. TL_BIAS is from PSoC internal voltage reference source of Vdd/2. It provides a bias to the circuit so that it can accept negative voltage.

Figure 3-2. Circuit Diagram

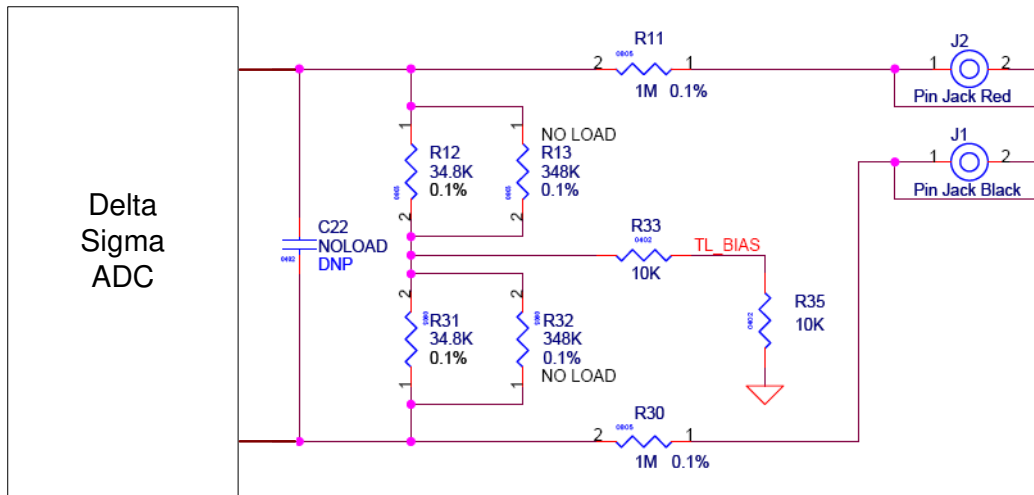

Note: TL_BIAS = Vdd /2

The differential input of the resistor networks is:

$$= (V1 - V2) / (K+1)$$

where $K=1M / 34.8k = 28.74$.

The resistor network successfully divides the input by a ratio of $(28.74+1) = 29.74$.

3.2 Functional Description – All Components

Table 3-1. Voltmeter Kit Components

No.	List of Device Features	Description
1	8 Digit LCD display (segment display)	Voltmeter provides resolution to 0.00006V for a source between -30V to +30V. It also displays the Thermocouple voltage
2	Removable mini-hook clips	For connecting target voltage measurement
3	Type K thermocouple	The short type K thermocouple is connected to P2 and P3 to provide the current for temperature sensing.
4	Source selecting button	The button (CSB1) selects the voltage source between the voltmeter and the thermocouple. The voltage of the selected source will be displayed on the LCD and on the PC.
5	LED D1 and D2, placed next to sources	LED D1 indicates Voltmeter is selected. LED D2 indicates thermocouple is selected.
6	Battery pack	The kit can be powered by one AA battery.
7	USB mini-B connector	To connect to PC or dual cell AA battery pack for power.
8	MiniProg3 (JTAG) connector	Allow programming, trace, and debug.

3.3 Button and Connector Functions

Symbol	Description
CSB1	Signal Source Selection between Voltmeter leads and Thermocouple
J1	Voltmeter input -
J2	Voltmeter input +
J3	MiniProg3
P1	USB connector Type mini-B
P2	Thermocouple +
P3	Thermocouple -
SW1	Power Source Selection between battery and USB

3.4 Power Supply Options

The kit can be powered in the following ways. The switch SW1 is used to select the source.

No.	Description	Typical Voltage	Connection	SW1
1	Direct external power	3.3V	TP1, TP2	Don't Care
2	Dual cell AA battery pack	3.3V	P1	Right
3	USB Power	5.0V	P1	Right
4	MiniProg3	5.0V or 3.0V	J3	Right

Make sure that only one voltage source is connected to the kit at a time.

4. Firmware



The design is based on PSoC 20-bit Sigma Delta ADC with differential input selected from either voltmeter or thermocouple input. An LED is used to indicate the source of the ADC signal. The firmware keeps reading the ADC input and outputting the value at the LCD. PSoC also monitors the SOURCE button continuously for user selection of the source and zero the offset of the thermocouple. Zero point calibration is to make the LCD output to display '0' and get the offset to add to the further voltage reading. Thus, the final voltage displayed will be equal to actual voltage added to the zero point offset. The LCD displays Null for zero point calibration when the button is pressed more than two seconds.

Figure 4-1. Firmware Flow Diagram

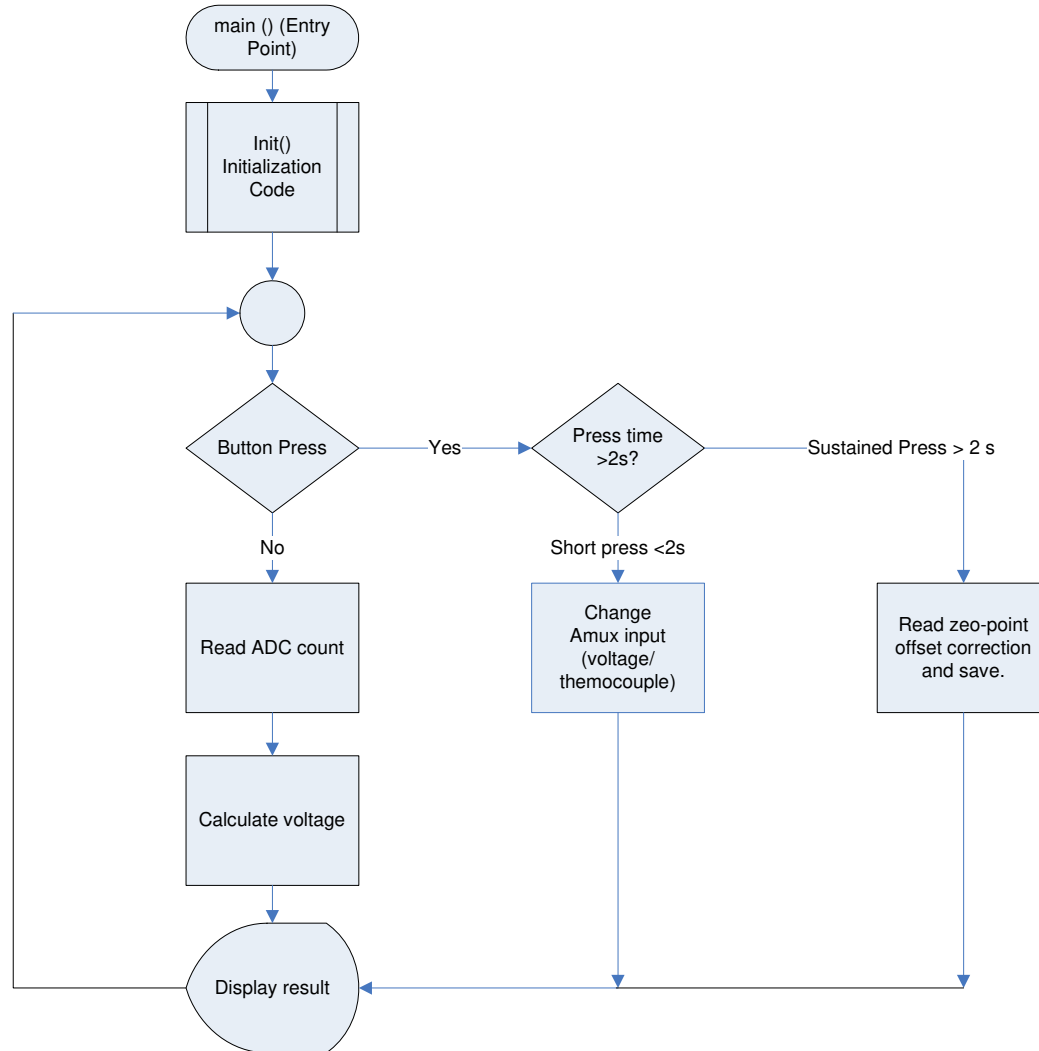
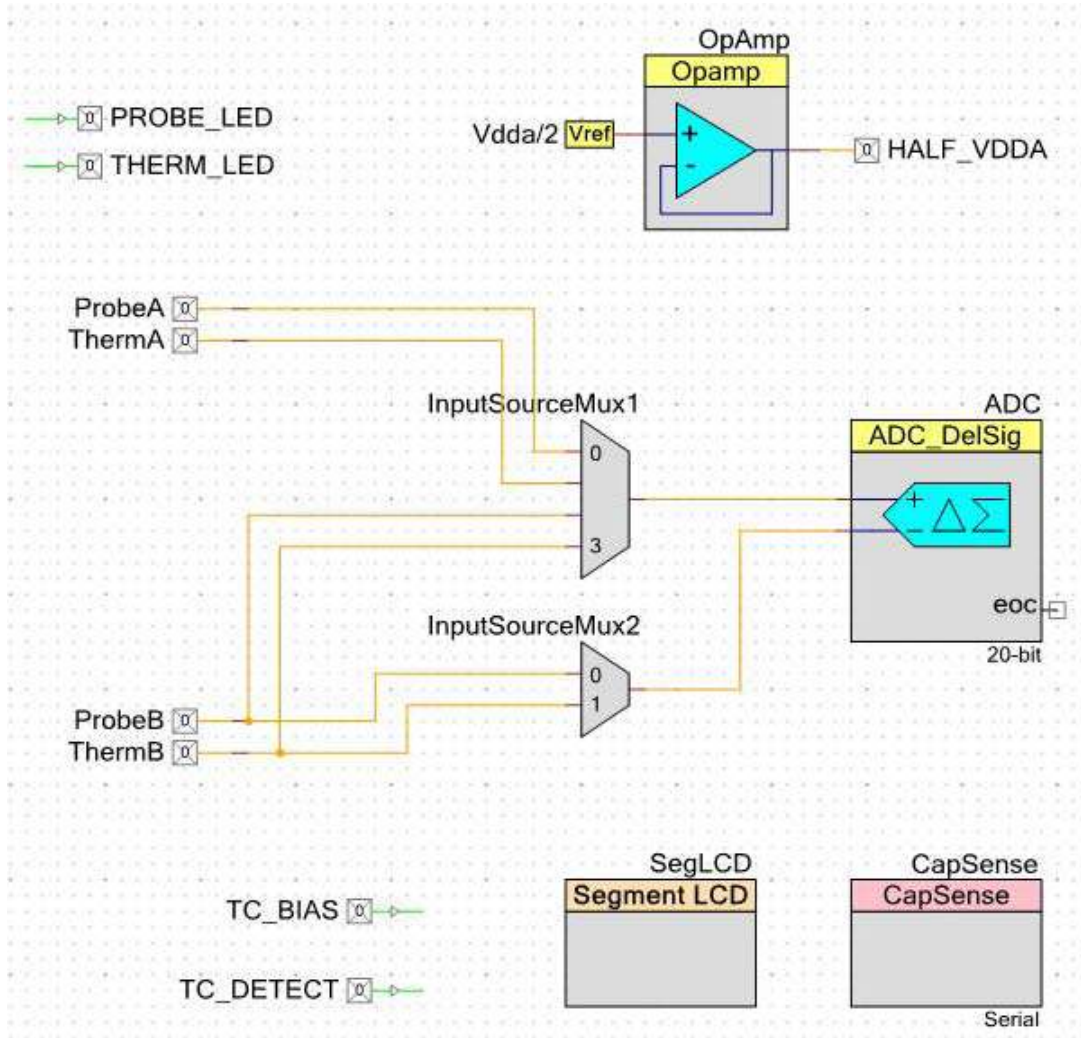

Figure 4-2. PSoC Creator Top Level Design for Voltmeter Project Firmware



PSoC Creator offers a very flexible software tool for user to create and configure the programmable peripherals.

4.1 ADC_DeISig

The Delta-Sigma ADC is the core component used in the Voltmeter. The ADC is used to sample an input voltage, takes the voltage from the Voltmeter mini-hook leads or thermocouple. Because the ADC is used to sample a differential input, the count returned is a 2's complement, 32-bit value. The count is then converted to a voltage value by the Voltmeter firmware.

Figure 4-3. Delta-Sigma ADC Component Configuration

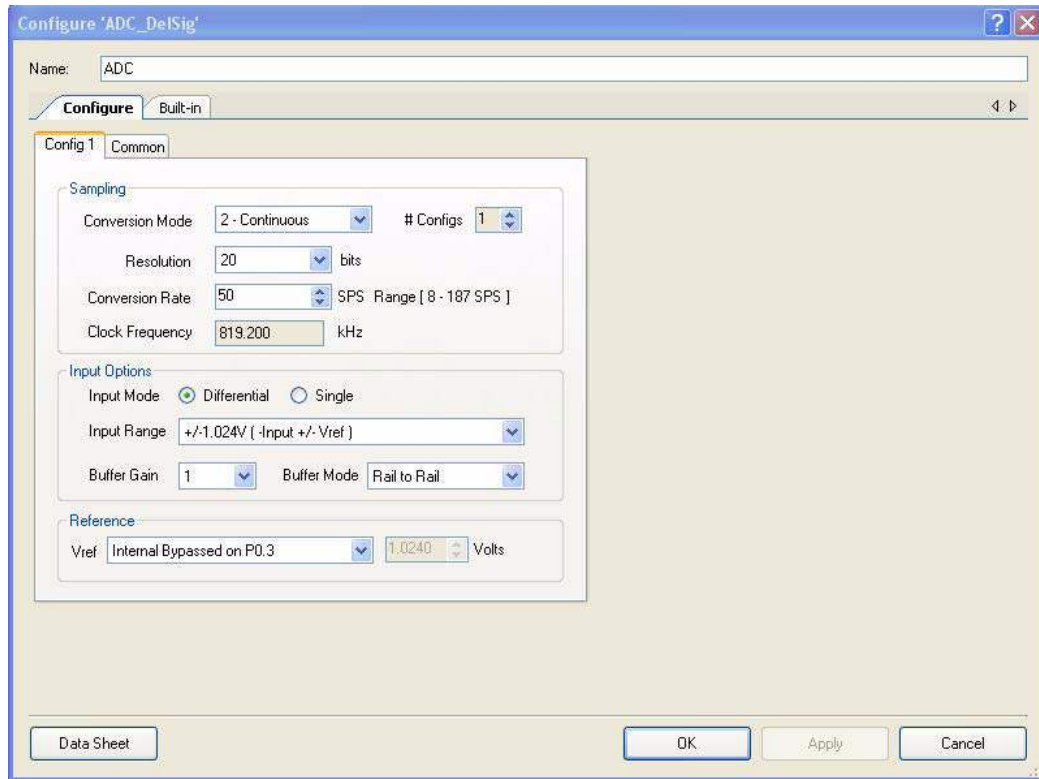

4.2 Analog Multiplexer (InputSourceMux)

The ADC samples a differential input provided by the two analog multiplexers. Output of InputSourceMux1 is connected to +ve input of the ADC and InputSourceMux2 output is connected to -ve input of ADC. The input to multiplexers can be selected between two voltage inputs: voltage probes or a thermocouple.

Figure 4-4. Analog Multiplexer1 Component Configuration

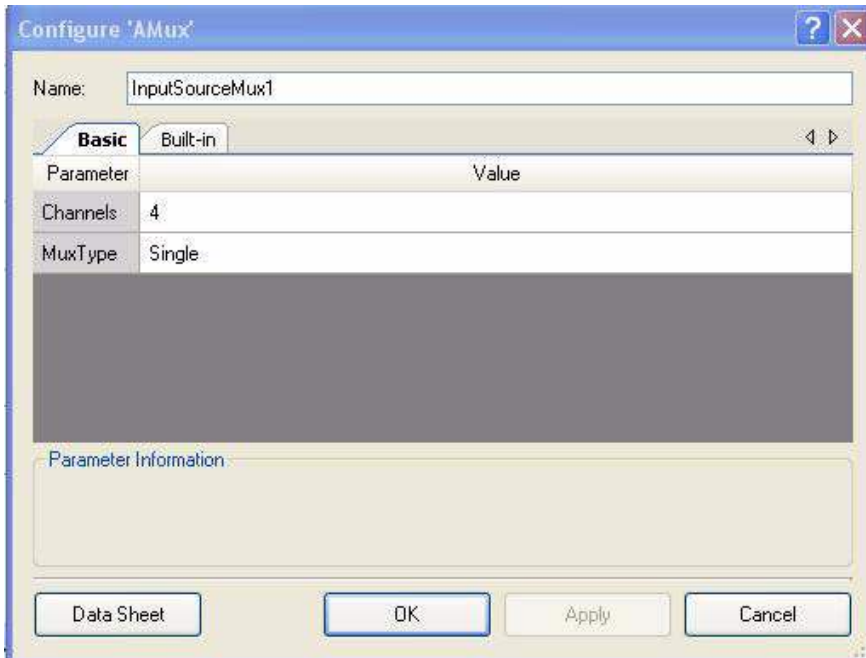
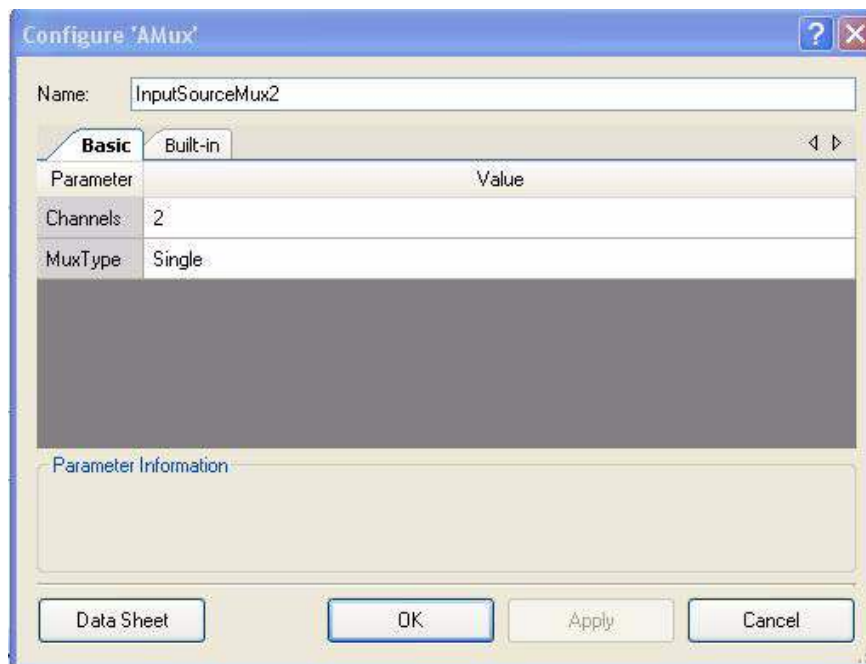

Figure 4-5. Analog Multiplexer2 Component Configuration



4.3 Opamp

The opamp is used to provide a reference for the ADC. It uses the internal reference $V_{dda}/2$ in follower mode. The opamp output is routed to port 3, pin 7, which is a common-mode reference for the voltmeter probe inputs.

Figure 4-6. Analog Buffer Component Configuration

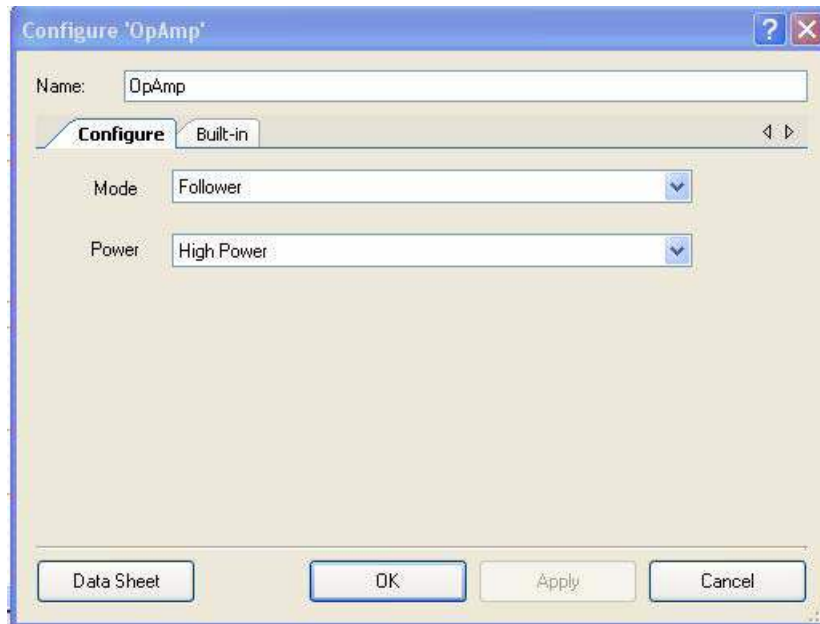

4.4 Segment LCD

The segment LCD component is used to display the voltage values computed by the voltmeter software. The component provides all analog and digital signals necessary to drive a thirty two segment, eight digit liquid crystal display using four common lines and thirty-two segment drive lines. As a stand-alone meter, this is the only output mechanism provided.

Figure 4-7. Segment LCD Component Configuration

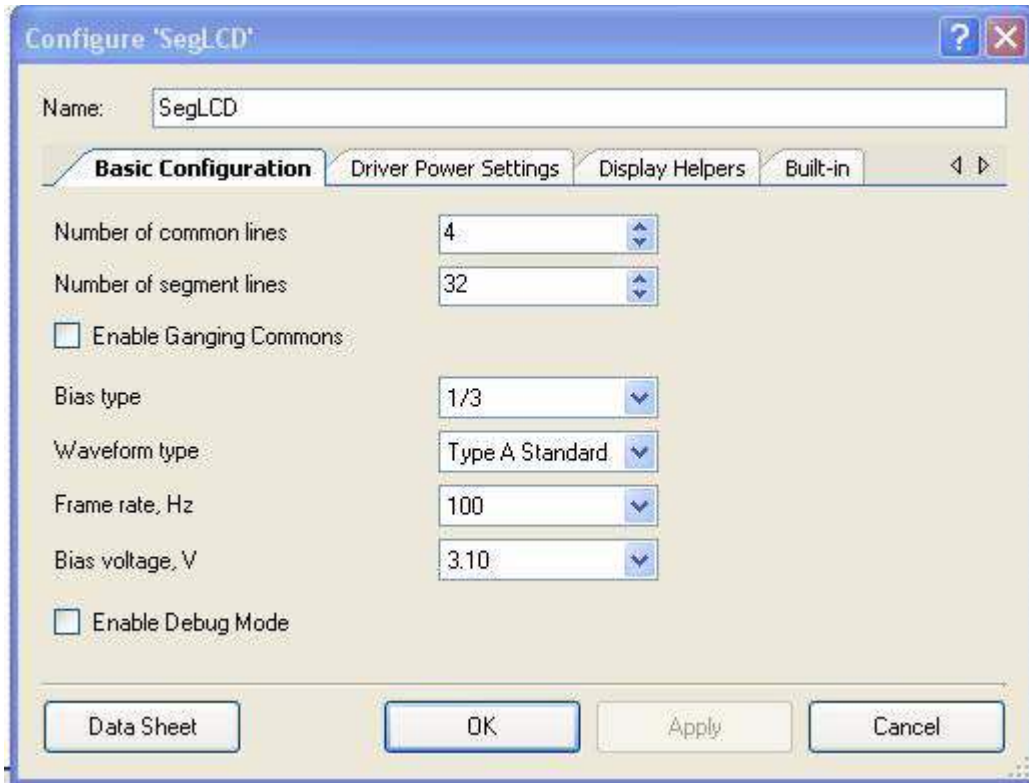

4.5 CapSense

The CapSense component is used to sense the presence of a touch on a circular touchpad area on the front of the voltmeter board. The capability required is minimal: a simple button press. CapSense button is used to select between sources: voltmeter leads or thermocouple.

Figure 4-8. CapSense Component Configuration

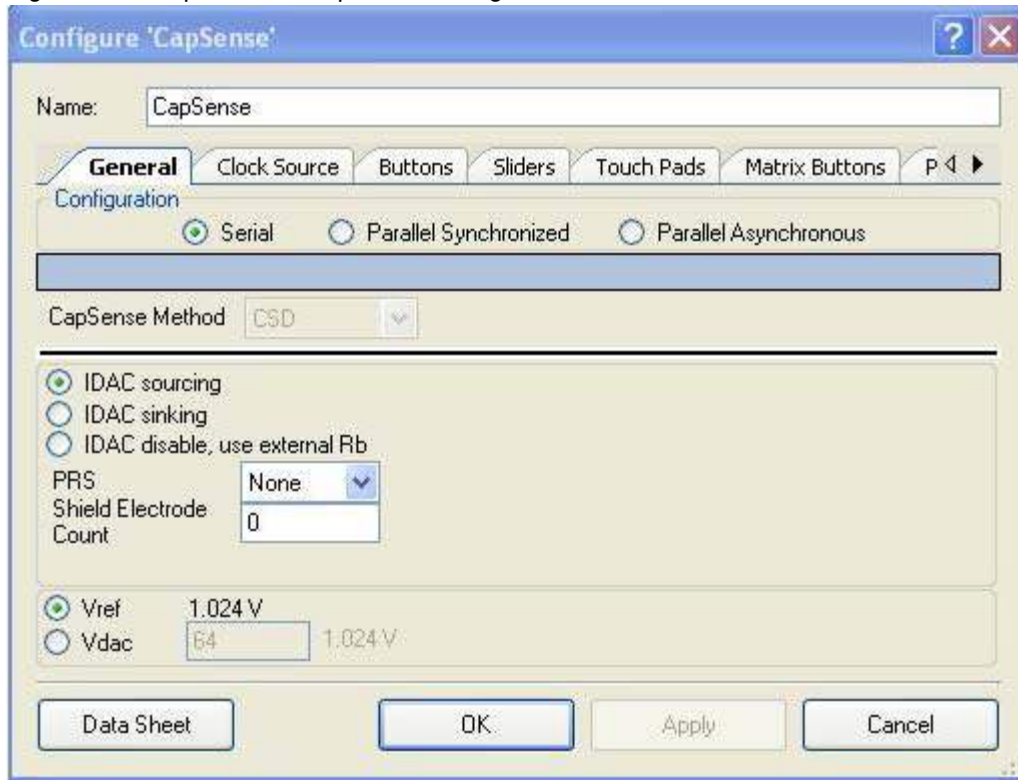

Figure 4-9. CapSense Clock Source Tab Configuration

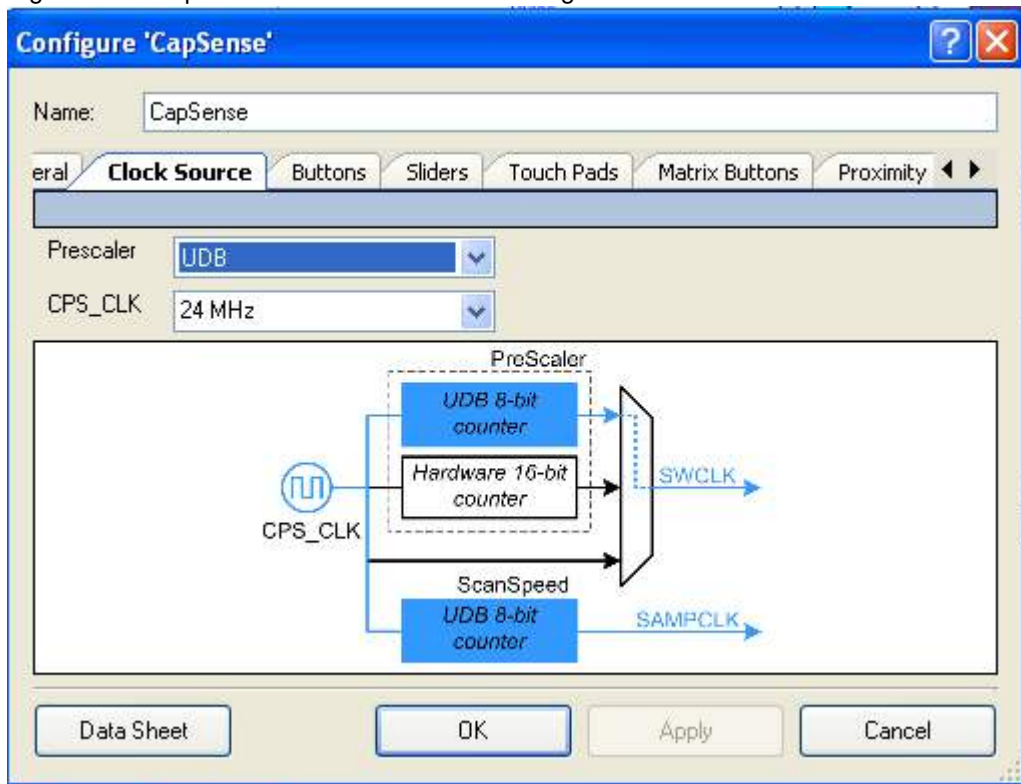

Figure 4-10. CapSense Button Configuration

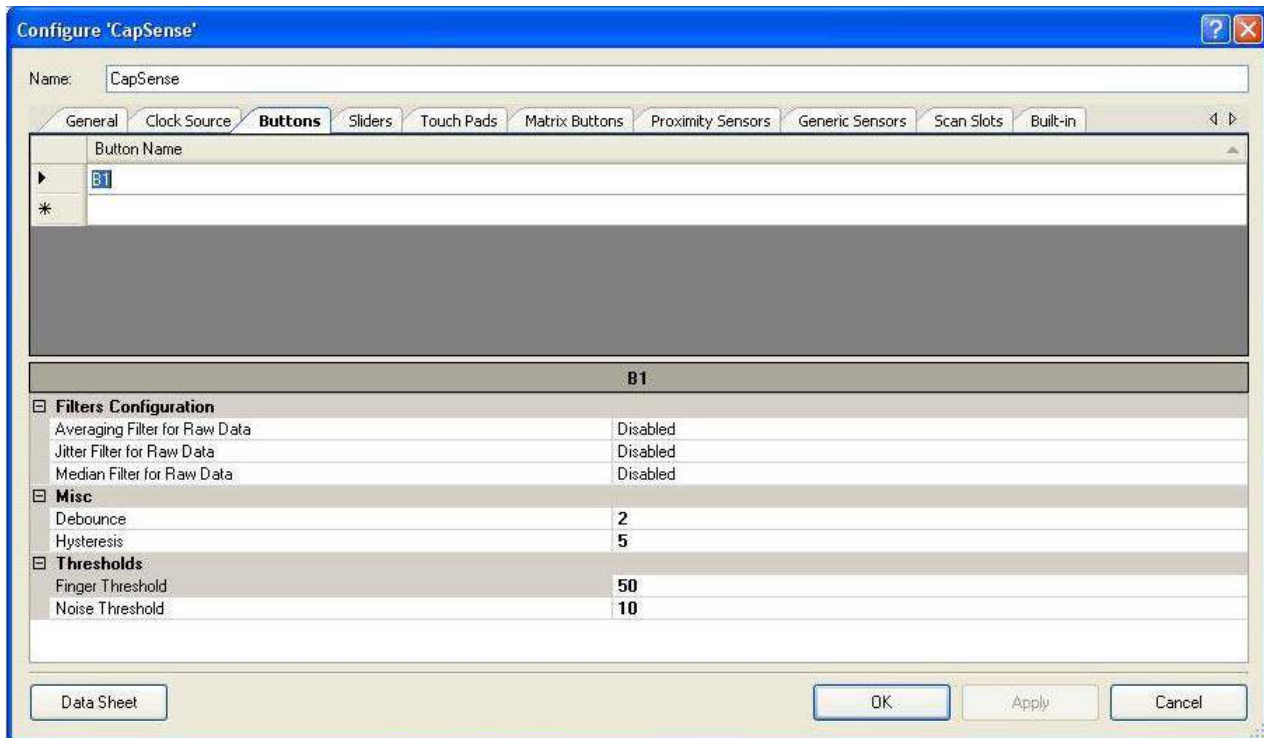
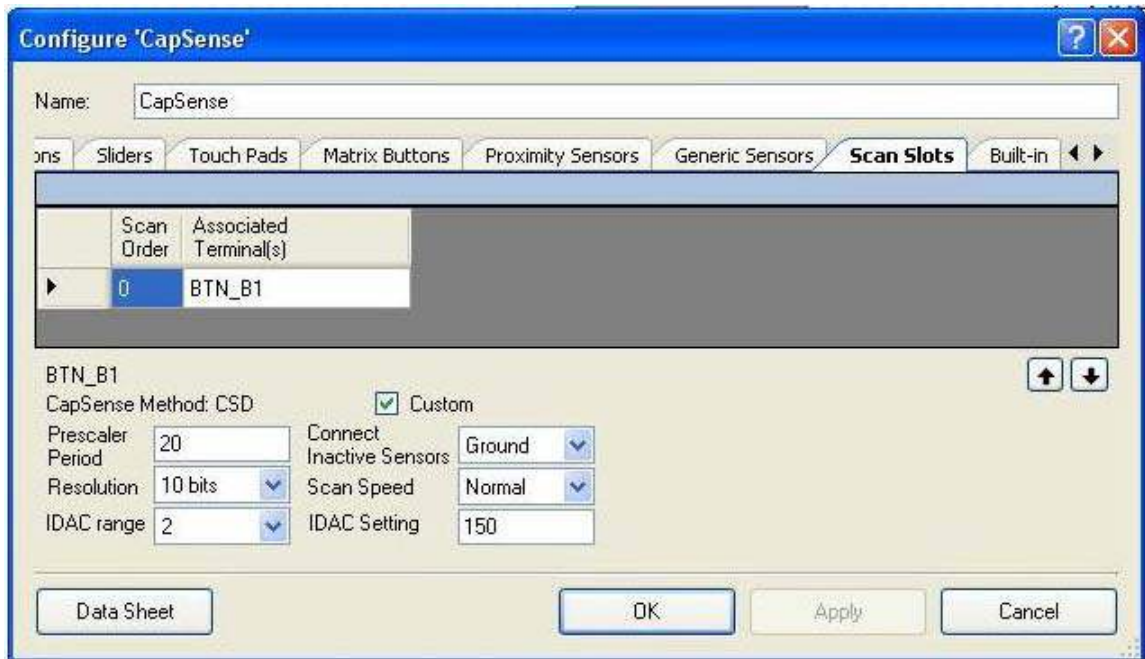

Figure 4-11. CapSense Scan Slots Configuration



A. Appendix



A.1 Schematic

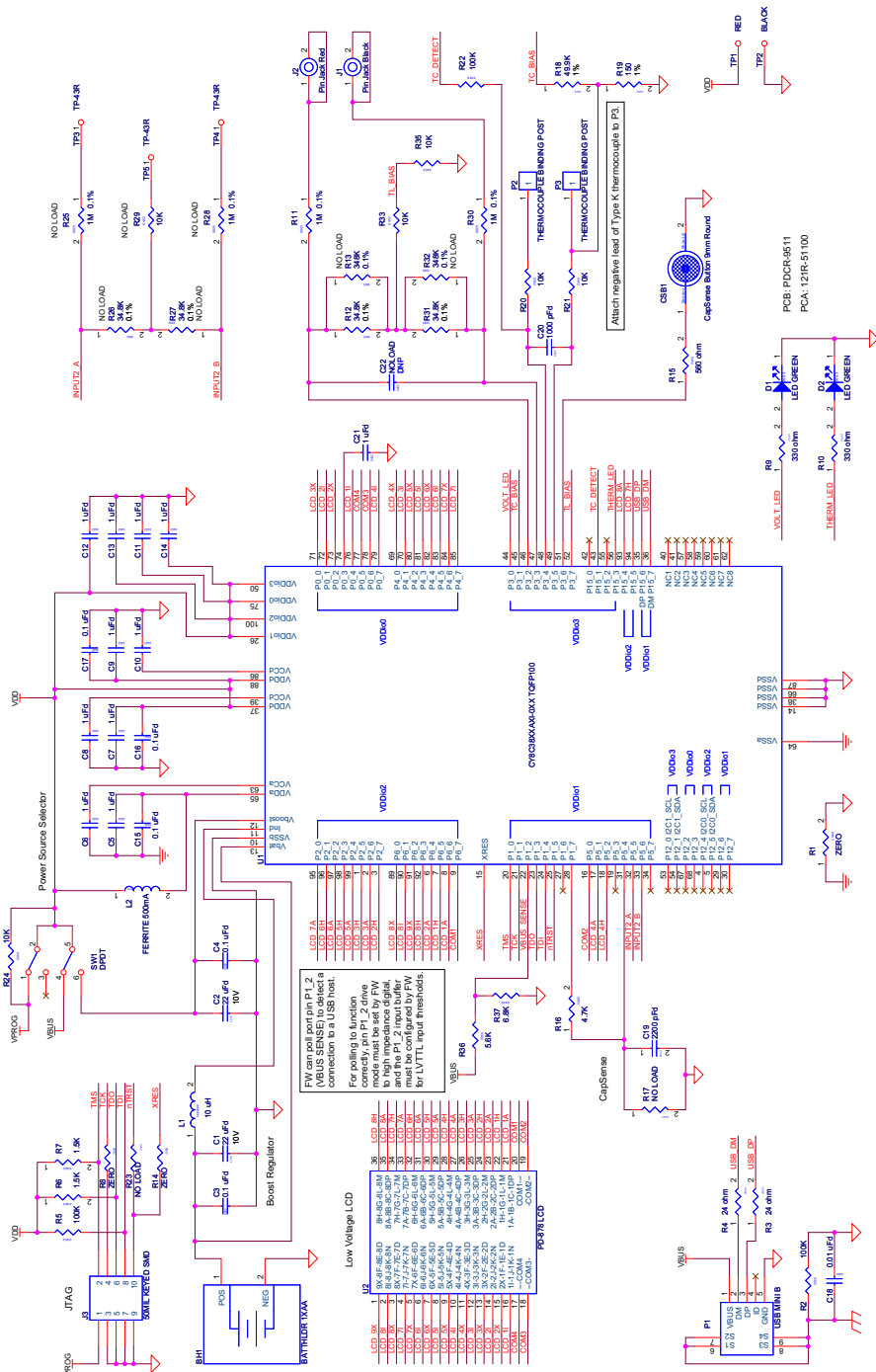

A.2 Bill of Materials

Item	Quantity	Reference	Description	Manufacturer	Manufacturer Part Number
			PCB	Cypress	PDCR-9511 REV**
1	2	C1,C2	CAP CER 22UF 10V 10% X5R 1210	Kemet	C1210C226K8PACTU
2	5	C3,C4,C15,C16,C17	CAP .10UF 10V CERAMIC X5R 0402	Kemet	C0402C104K8PACTU
3	11	C5,C6,C7,C8,C9,C10,C11,C12,C13,C14,C21	CAP 1 uF 6.3V CERAMIC X5R 0402	Panasonic	ECJ-0EB0J105M
4	1	C18	CAP 10000PF 16V CERAMIC 0402 SMD	Panasonic - ECG	ECJ-0EB1C103K
5	1	C19	CAP CER 2200PF 50V 5% C0G 0603	Murata	GRM1885C1H222JA01D
6	1	C20	CAP 1000PF 50V CERAMIC X7R 0402	Panasonic - ECG	ECJ-0EB1H102K
7	2	D1,D2	LED GREEN CLEAR 0603 SMD	Lite-On Trading USA, Inc.	LTST-C190GKT
8	1	J1	JACK TEST HORZ LOW PRO BLACK AU	Keystone Electronics	6062
9	1	J2	JACK TEST HORZ LOW PRO RED AU	Keystone Electronics	6061
10	1	J3	CONN HEADER 10 PIN 50MIL KEYED SMD	Samtec	FTSH-105-01-L-DV-K
11	1	L1	COIL PWR CHOKE 10UH 1A SMD	Panasonic - ECG	ELL-6PM100M
12	1	L2	FERRITE CHIP 120 OHM 500MA 0603 SMD	TDK Corporation	MMZ1608S121A
13	1	P1	CONN USB MINI B SMT RIGHT ANGLE	TYCO	1734035-2
14	2	P2,P3	Mini Binding Post	Keystone Electronics	8730
15	1	R1	RES 0.0 OHM 1/10W 5% 0805 SMD	Panasonic-ECG	ERJ-6GEY0R00V
16	3	R2,R5,R22	RES 100K OHM 1/16W 5% 0402 SMD	Panasonic - ECG	ERJ-2GEJ104X
17	2	R3,R4	RES 24 OHM 1/16W 5% 0603 SMD	Panasonic - ECG	ERJ-3GEYJ240V
18	2	R6,R7	RES 1.50K OHM 1/16W 1% 0402 SMD	Panasonic - ECG	ERJ-2RKF1501X

Item	Quantity	Reference	Description	Manufacturer	Manufacturer Part Number
19	2	R8,R14	RES ZERO OHM 1/16W 0402 SMD	Panasonic - ECG	ERJ-2GE0R00X
20	2	R9,R10	RES 330 OHM 1/16W 5% 0603 SMD	Panasonic - ECG	ERJ-3GEYJ331V
21	2	R11,R30	RES 1.0M OHM 1/8W .1% 0805 SMD	Susumu Co Ltd	RG2012P-105-B-T5
22	2	R12,R31	RES 34.8K OHM 1/8W .1% 0805 SMD	Susumu Co Ltd	RG2012P-3482-B-T5
23	1	R15	RES 560 OHM 1/16W 5% 0402 SMD	Yageo Corporation	RC0402JR-07560RL
24	1	R16	RES 4.7K OHM 1/10W 5% 0805 SMD	Panasonic - ECG	ERJ-6GEYJ472V
25	1	R18	RES 49.9K OHM 1/10W 1% 0603 SMD	Panasonic - ECG	ERJ-3EKF4992V
26	1	R19	RES 150 OHM 1/10W 1% 0603 SMD	Panasonic - ECG	ERJ-3EKF1500V
27	5	R20,R21,R24,R33,R35	RES 10K OHM 1/16W 5% 0402 SMD	Yageo	RC0402JR-0710KL
28	1	R36	RES 5.6K OHM 1/16W 5% 0402 SMD	Panasonic - ECG	ERJ-2GEJ562X
29	1	R37	RES 6.8K OHM 1/16W 5% 0402 SMD	Panasonic - ECG	ERJ-2GEJ682X
30	1	SW1	SW SLIDE DPDT 6VDC 0.3A PCMNT	C&K Components	JS202011AQN
31	1	TP1	TEST POINT 43 HOLE 65 PLATED RED	Keystone Electronics	5000
32	1	TP2	TEST POINT 43 HOLE 65 PLATED BLACK	Keystone Electronics	5001
33	1	U1	PSoC 3 Mixed-Signal Array	Cypress Semiconductor	CY8C38XXAXI-0XX
34	1	U2	LCD 14SEG 8DIG 0.275" REFL STD	Pacific Display Devices	PD-878-DP-RC-S-LV-6
35	1	LABEL	PCA and Serial Number Barcode Label		

Item	Quantity	Reference	Description	Manufacturer	Manufacturer Part Number
NO LOAD Components					
36	1	TC1	OMEGA Thermocouple Type K	OMEGA	CHAL-020
37	2	N/A	STANDOFF HEX 1.000/4-40THR NYLON	Keystone Electronics	1902E
38	2	N/A	SCREW MACH PHIL 4-40X3/8 NYLON	Building Fasteners	NY PMS 440 0038 PH
39	1	BH1	HOLDER BATTERY 1CELL AA PC MNT	Keystone Electronics	2460
40	1	C22	CAP 0402 NO LOAD	NA	NA
41	2	R13,R32	RES 348K OHM 1/8W .1% 0805	Susumu Co Ltd	RG2012P-3483-B-T5
42	1	R17	RES NO LOAD 0603 SMD	NA	NA
43	1	R23	RES NO LOAD 0402 SMD	NA	NA
44	2	R26,R27	RES 34.8K OHM 1/8W .1% 0805 SMD	Susumu Co Ltd	RG2012P-3482-B-T5
45	2	R25,R28	RES 1.0M OHM 1/8W .1% 0805 SMD	Susumu Co Ltd	RG2012P-105-B-T5
46	1	R29	RES 10K OHM 1/16W 5% 0402 SMD	Yageo	RC0402JR-0710KL
47	1	CSB1	CapSense Button 9mm Round	NA	NA
48	3	TP3,TP4,TP5	TEST POINT 43 HOLE 65 PLATED	NA	NA

A.3 PCB Layout and Silkscreen

Figure A-1. Primary Side

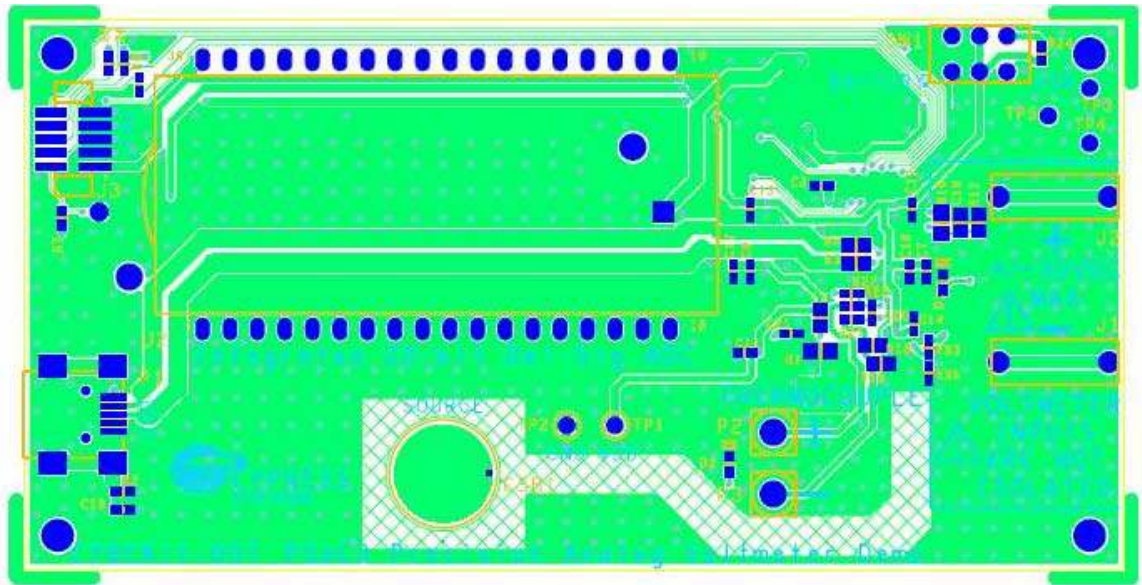

PDCR-9511 REV ** PRIMARY SIDE

PDCR-9511 REV ** PRIMARY SILKSCREEN

Figure A-2. Secondary Side

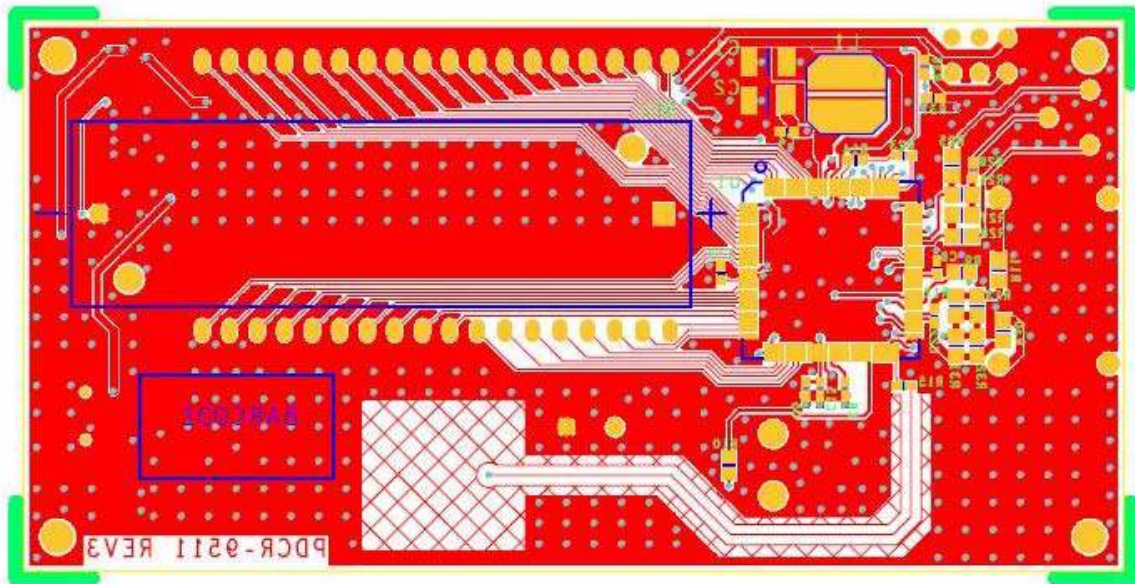

PDCR-0211 REV **SECONDARY SIDE

PDCR-0211 REV **SECONDARY SILKSCREEN

A.4 Assembly Drawing

Figure A-3. Primary Side

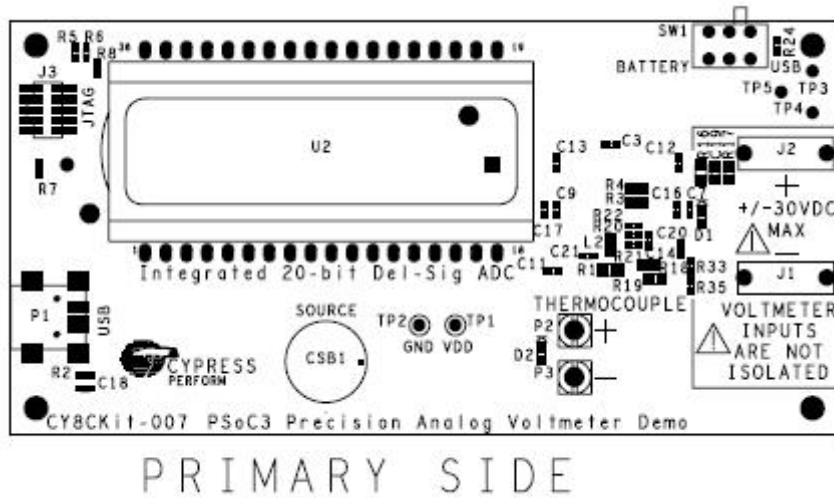

Figure A-4. Secondary Side

