IP68 EMC Hood and Housing Series

Table of contents

1. INTRODUCTION	2
2. SUPPORTING DOCUMENTS	2
2.1 Customer drawings	2
2.2 Product specification	2
2.3 Application Specification	2
2.4 Standards	2
3. DESCRIPTION	3
3.1 Assembly product	3
3.2 EMC anti corrosion hood and housing types	4
3.2.1 Central locking	4
3.2.1.1 Normal type	4
3.2.1.2 EMC anti corrosion hood _high construction	5
3.2.1.3 EMC anti corrosion housing _with conductive seal	5
3.2.1.4 EMC anti corrosion housing _surface mounting	6
3.2.2 Opposite angle locking	6
3.2.2.1 Normal type	6
3.2.2.2 EMC anti corrosion hood _two top entry	7
3.2.2.3 EMC anti corrosion housing _surface mounting	8
3.2.2.4 EMC anti corrosion protection cover	8
4. REQUIREMENTS	9
4.1 Panel cut-out	9
5. ASSEMBLY	12
6. STORAGE	17

1. INTRODUCTION

This specification contains the regulations for assembly of various IP68 EMC anti corrosion Hood and Housing.

The following components are available in this system:

IP68 EMC anti corrosion hood and housing: H6BPR/H10BPR/H16BPR/H24BPR.

2. SUPPORTING DOCUMENTS

2.1 Customer drawings

For dimensions and materials of the individual parts, please refer to the relative customer drawings of IP68 EMC anti corrosion hood and housing H6BPR/H10BPR/H16BPR/H24BPR.

2.2 Product specification

The product specifications of the used articles are to be taken into account. The product specification describes the technical data as regulations, temperature range and degree of protection. For further reference, please refer to product spec. 108-137191.

2.3 Application Specification

Connectors shall be assembled as below mentioned application specifications to ensure correct connector assembly.

2.4 Standards

- EN 61984: Connectors - Safety requirements and tests
- IEC 60664-1: Insulation coordination for equipment within low-voltage systems (Part 1)
- EN 60529: Degrees of Protection Provided by Enclosures (IP Code)
- EN 60068: Environmental testing
- EN 62153-4-7: Electromagnetic compatibility (EMC) - Test method for measuring the transfer impedance and the screening - or the coupling attenuation - Tube in tube method
- ISO 6988: Metallic and other non-organic coatings - Sulfur dioxide test with general condensation of moisture

3. DESCRIPTION

3.1 Assembly product

The following picture (Figure 1) shows an example of complete assembly product.

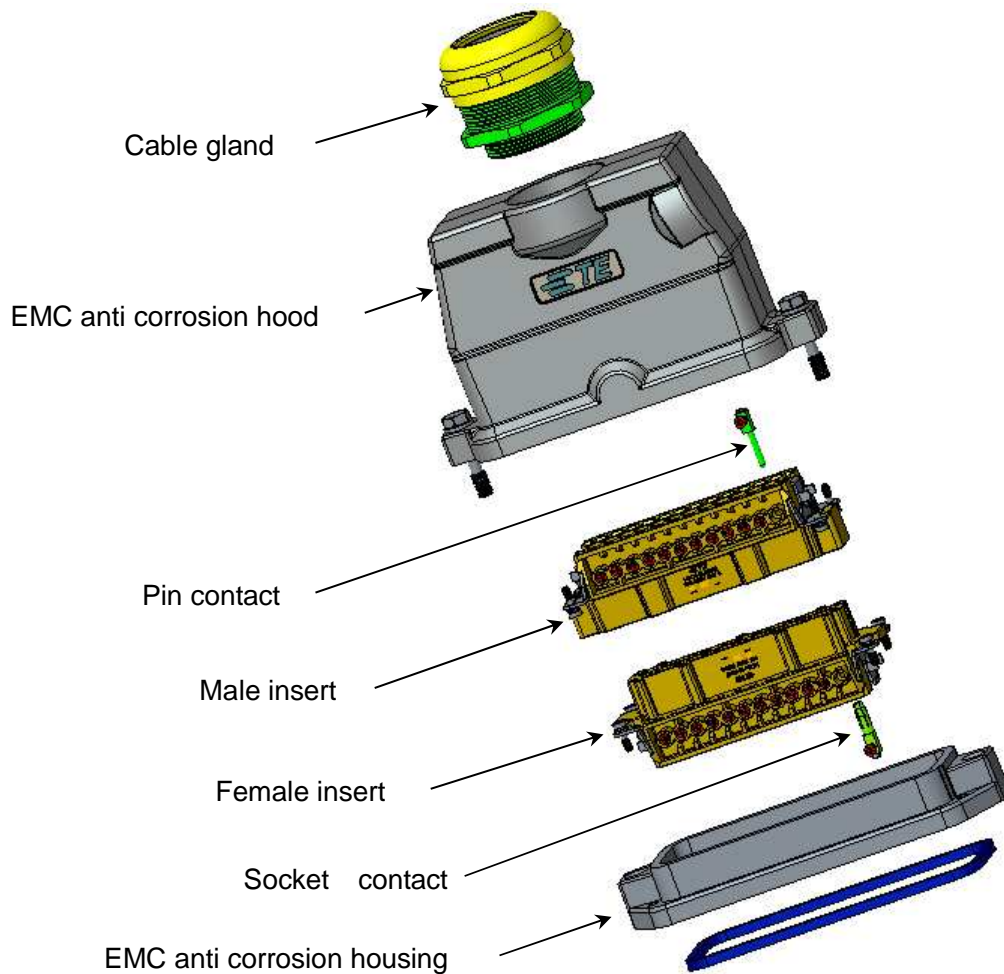

Figure: 1

The complete product consists of the following components (see figure 1):

- Cable gland
- EMC anti corrosion hood
- Pin contact
- Male insert
- Female insert
- Socket contact
- EMC anti corrosion housing

3.2 EMC anti corrosion hood and housing types

3.2.1 Central locking

3.2.1.1 Normal type

EMC anti corrosion hood:

- HXXBPR-TSHC-PG/M-EMC-C
- HXXBPR-TGHC- PG/M-EMC-C
- HXXBPR-TS/GHC- PG/M-EMC-C

EMC anti corrosion housing:

- HXXBPR-AGC-EMC-C

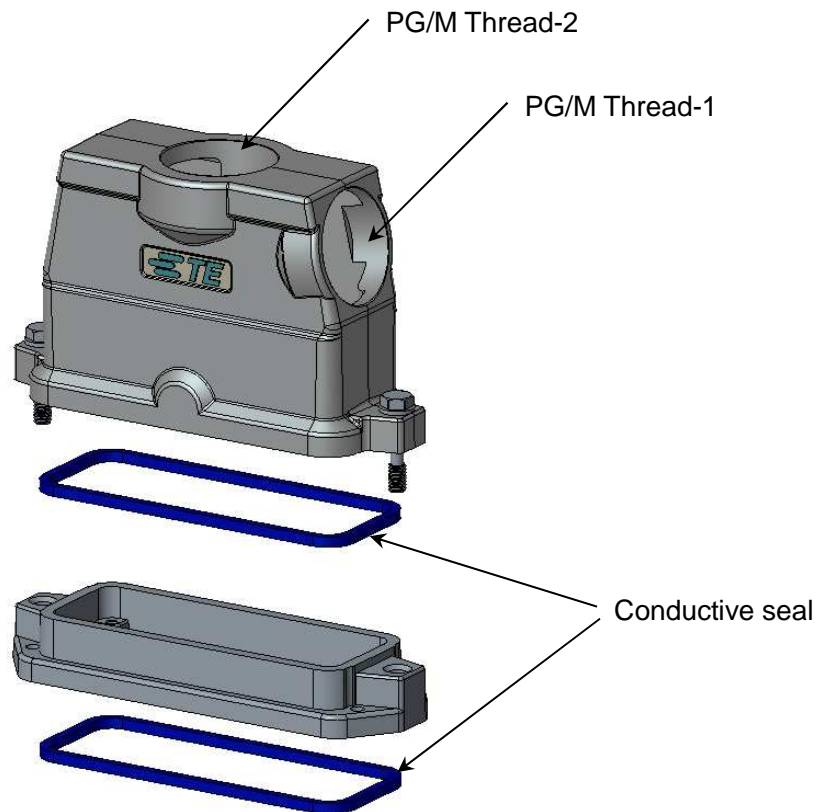

Figure: 2

- EMC anti corrosion hood & housing available for size: H6B,H10B, H16B, H24B
- PG/M Thread-1 optional: Blank, PG16,PG21,PG29,PG36,M20,M25,M32,M40
- PG/M Thread-2 optional: Blank, PG16,PG21,PG29,PG36,M20,M25,M32,M40

Notes: Different hood& housing size has different optional PG/M Thread-X. Refer to drawings for detailed information.

3.2.1.2 EMC anti corrosion hood _high construction

- HXXBPR-H130-TG/SHC-PG/M-EMC-C

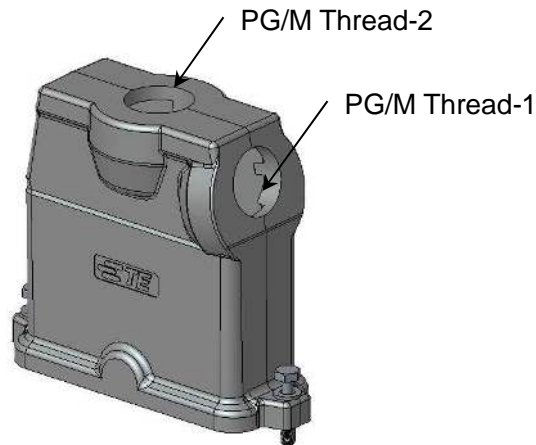

Figure: 3

- EMC anti corrosion hood available for size, Ex.: H24B
- PG/M Thread-1 optional: Blank, G16,PG21,PG29,PG36,M20,M25,M32,M40,M50
- PG/M Thread-2 optional: Blank, G16,PG21,PG29,PG36,M20,M25,M32,M40,M50

Notes: Different hood size has different optional PG/M Thread-X. Refer to drawings for detailed information.

3.2.1.3 EMC anti corrosion housing _with conductive seal

- HXXBPR-AGC-EMC-C

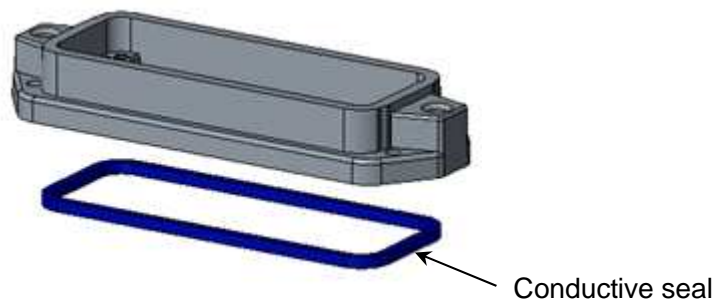

Figure: 4

- EMC anti corrosion housing available for size: H6B, H10B, H16B, H24B
- Conductive seal available for size: H6B, H10B, H16B, H24B

3.2.1.4 EMC anti corrosion housing _surface mounting

- HXXBPR-AGCT-EMC-C

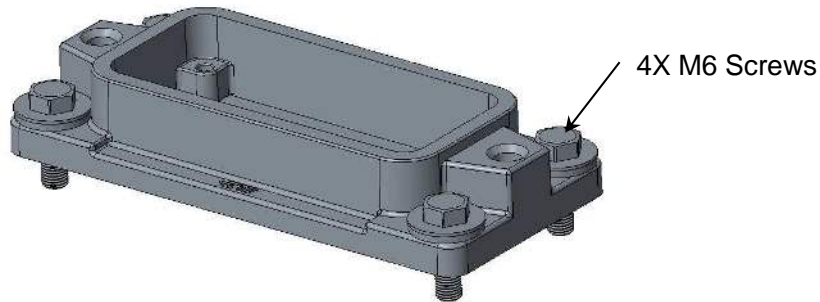

Figure: 5

- EMC anti corrosion housing available for size, Ex.: H16B

3.2.2 Opposite angle locking

3.2.2.1 Normal type

EMC anti corrosion hood:

- HXXBPR-TSH-PG/M-EMC-C
- HXXBPR-TGH- PG/M-EMC-C
- HXXBPR-TS/GH- PG/M-EMC-C

EMC anti corrosion housing:

- HXXBPR-AG-EMC-C

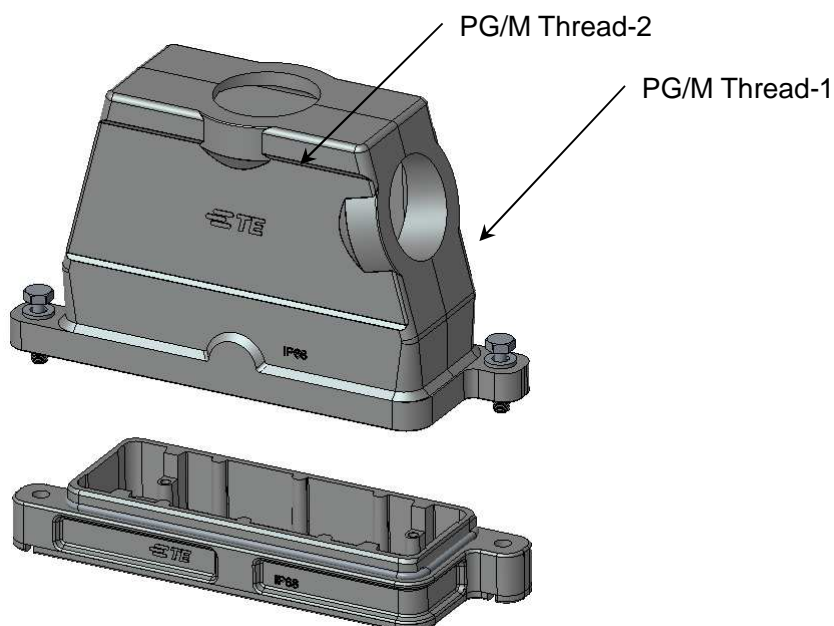

Figure: 6

- EMC anti corrosion hood & housing available for size: H6B,H10B, H16B, H24B
- PG/M Thread-1 optional: Blank, PG16,PG21,PG29,PG36,M20,M25,M32,M40
- PG/M Thread-2 optional: Blank, PG16,PG21,PG29,PG36,M20,M25,M32,M40

Notes: Different housing size has different optional PG/M Thread-X. Refer to drawings for detailed information.

3.2.2.2 EMC anti corrosion hood _two top entry

- HXXBPR-TGH-PG/M-EMC-C

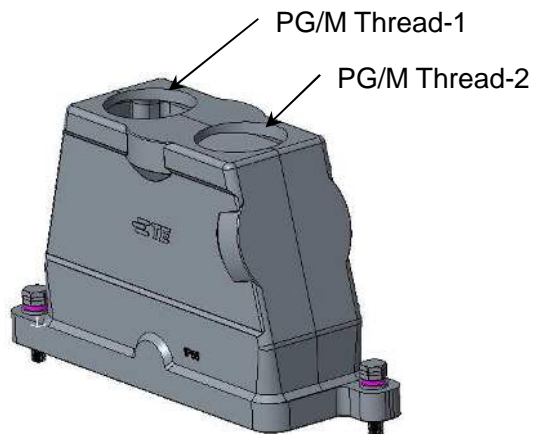

Figure: 7

- EMC anti corrosion hood available for size, Ex.: H10B,H16B,H24B
- PG/M Thread-1 optional: Blank, PG16,PG21,PG29,M20,M25,M32,M40
- PG/M Thread-2 optional: Blank, PG16,PG21,PG29,M20,M25,M32,M40

Notes: Different housing size has different optional PG/M Thread-X. Refer to drawings for detailed information.

3.2.2.3 EMC anti corrosion housing _surface mounting

- HXXBPR-SGRH-PG/M-EMC-C

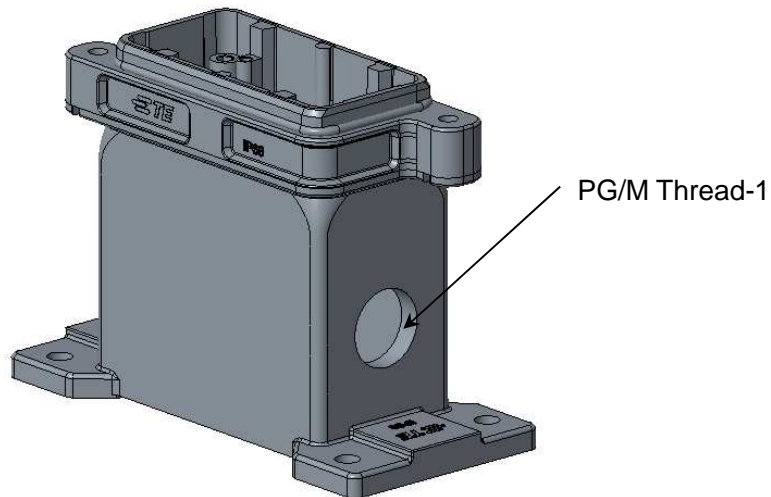

Figure: 8

- EMC anti corrosion hood available for size, Ex.: H10B
- PG/M Thread-1 optional: Blank, PG16,PG21,PG29,M20,M25,M32

Notes: Different housing size has different optional PG/M Thread-X. Refer to drawings for detailed information.

3.2.2.4 EMC anti corrosion protection cover

- HXXBPR-KDB-EMC-C



Figure: 9

- EMC anti corrosion protection cover available for size: H6B,H10B, H16B, H24B

4. REQUIREMENTS

4.1 Panel cut-out

- For EMC anti corrosion bulkhead mounting housing

More detailed information also can be found from related customer drawings

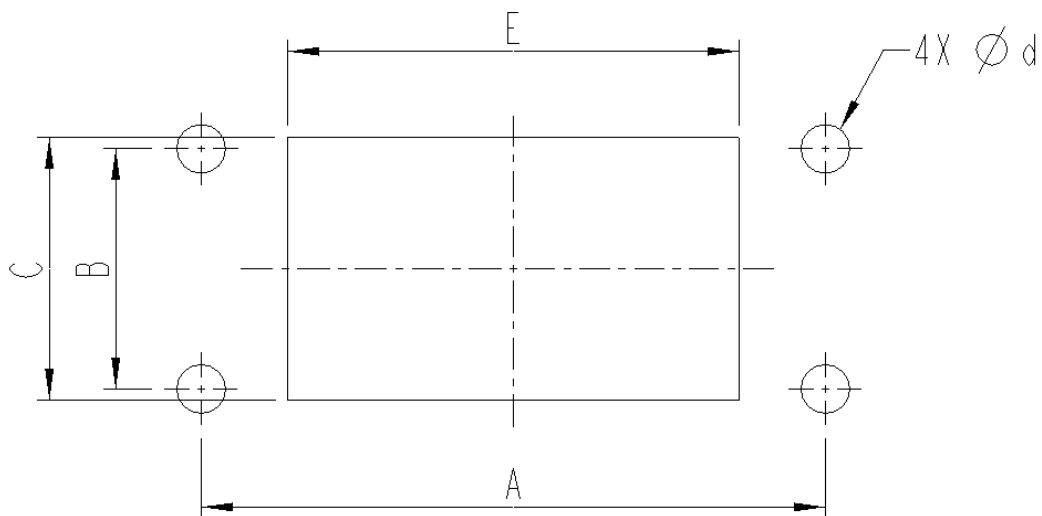

Figure: 10

EMC anti corrosion housing size	Dimension(mm)					
	A	B	C	d		E
				Central locking	Opposite angle locking	
H6B	70	32	35	For M4 screw	For M6 screw	48
H10B	83	32	35	For M4 screw	For M6 screw	60
H16B	103	32	35	For M4 screw	For M6 screw	82
H246B	130	32	35	For M4 screw	For M6 screw	108

- For EMC anti corrosion surface mounted housings
HXXBPR-SGRH-PG/M-EMC-C
Information also can be found from related customer drawings

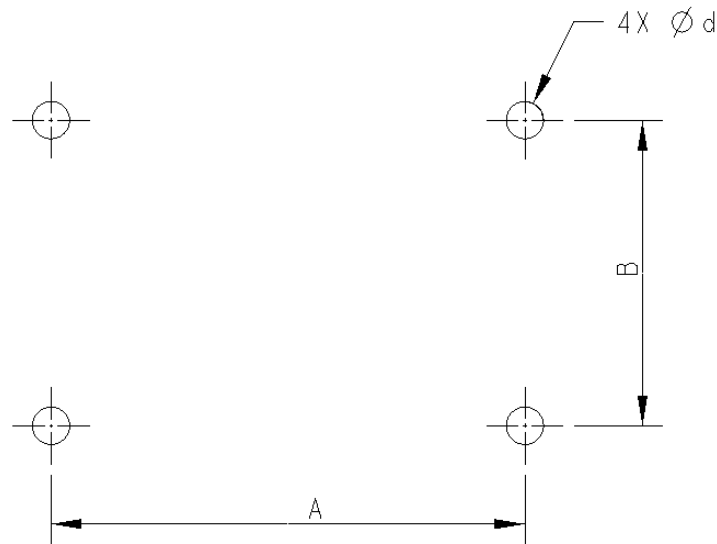

Figure: 11

	EMC anti corrosion housing size	Dimension(mm)		
		A	B	d
				Opposite angle locking
HXXBPR-SGRH-PG/M-EMC-C	H10B	140	60	For M8 screw

- For EMC anti corrosion bulkhead flange mounted housings
HXXBPR-AGCT-EMC-C
Information also can be found from related customer drawings.

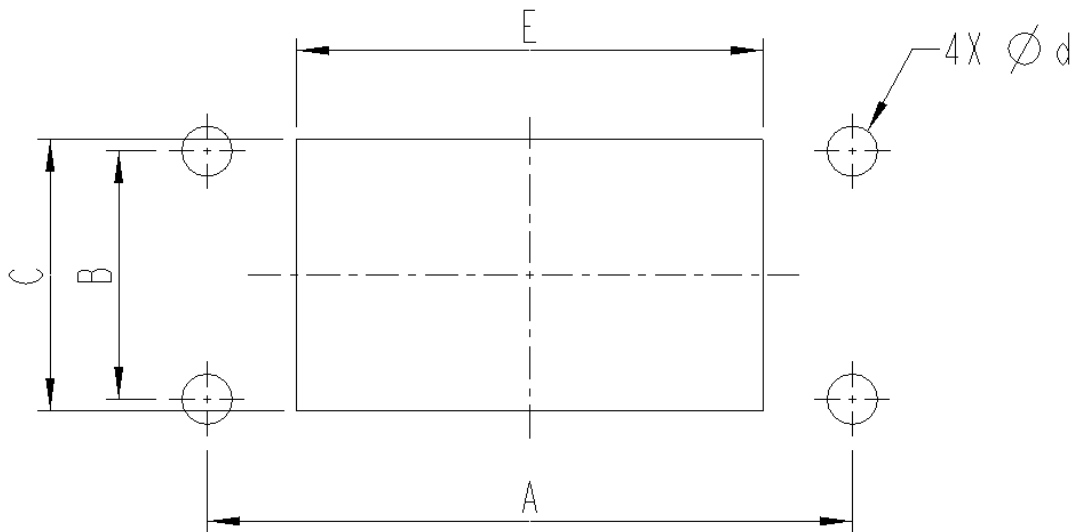

Figure: 12

EMC anti corrosion housing size	Dimension(mm)				
	A	B	C	d	E
H16B	112.5	35	43	For M6 screw	82

5. ASSEMBLY

➤ Assembly housing

For central locking

Fix EMC anti corrosion housing with 4 x M4 screws. Tightening torque refer to spec of screws, but no less than 2Nm.

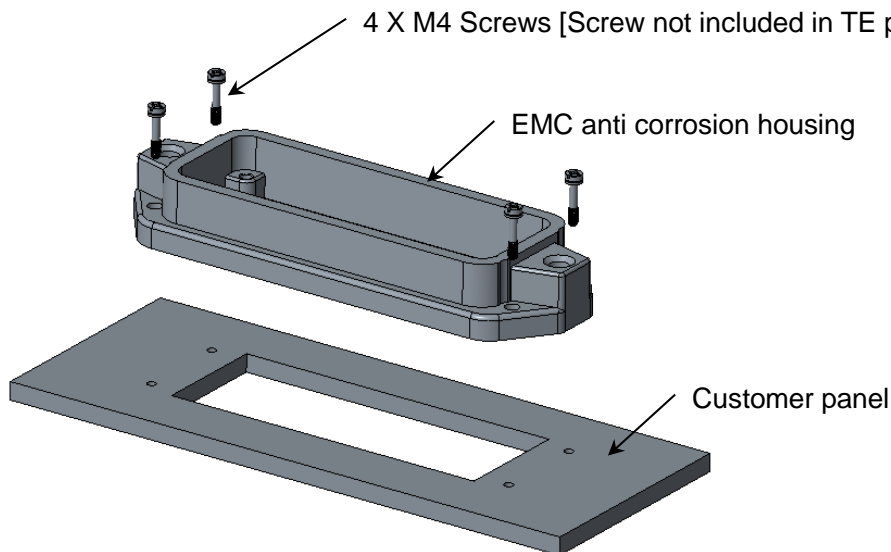

Figure: 13

For opposite angle locking

Fix EMC anti corrosion housing with 4 x M6 screws. Tightening torque refer to spec of screws, but no less than 4Nm.

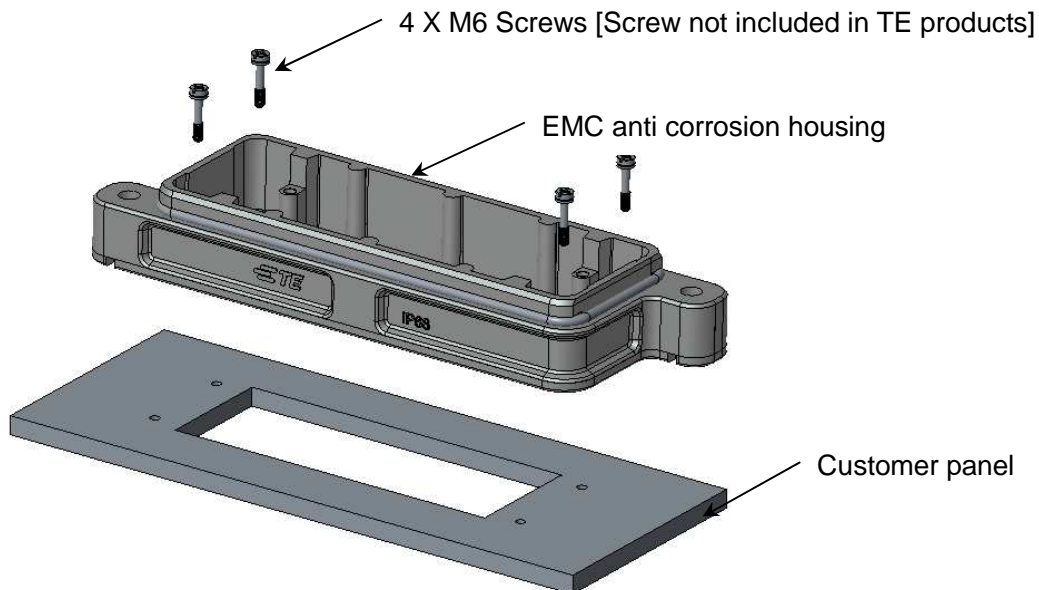

Figure: 14

For surface mounting locking

- HXXBPR-SGRH-PG/M-EMC-C

Fix EMC anti corrosion housing with 4 x M8 screws. Tightening torque refer to spec of screws, but no less than 5Nm

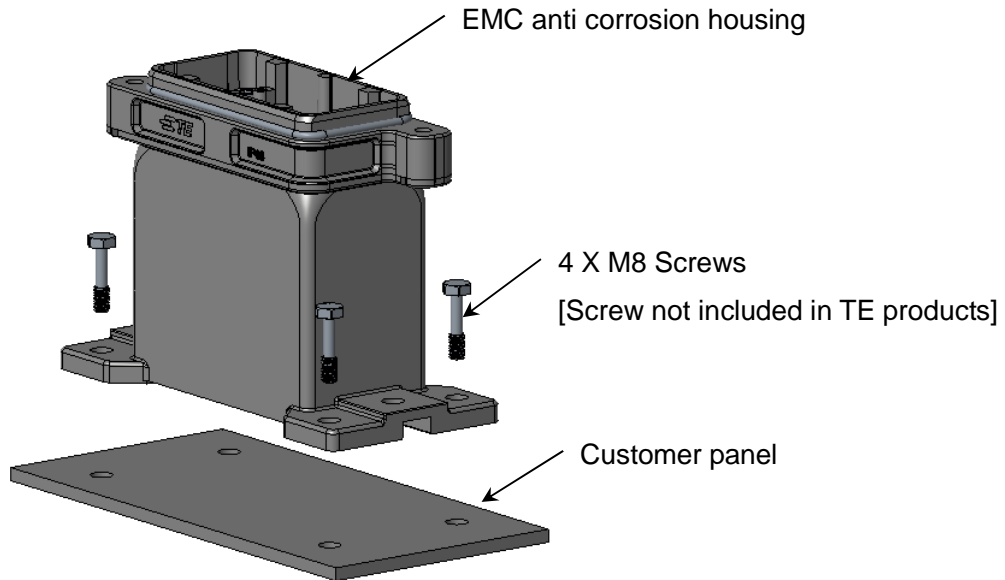

Figure: 15

- HXXBPR-AGCT-EMC-C

Fix EMC anti corrosion housing with 4 x M6 screws. Tightening torque refer to spec of screws, but no less than 4Nm

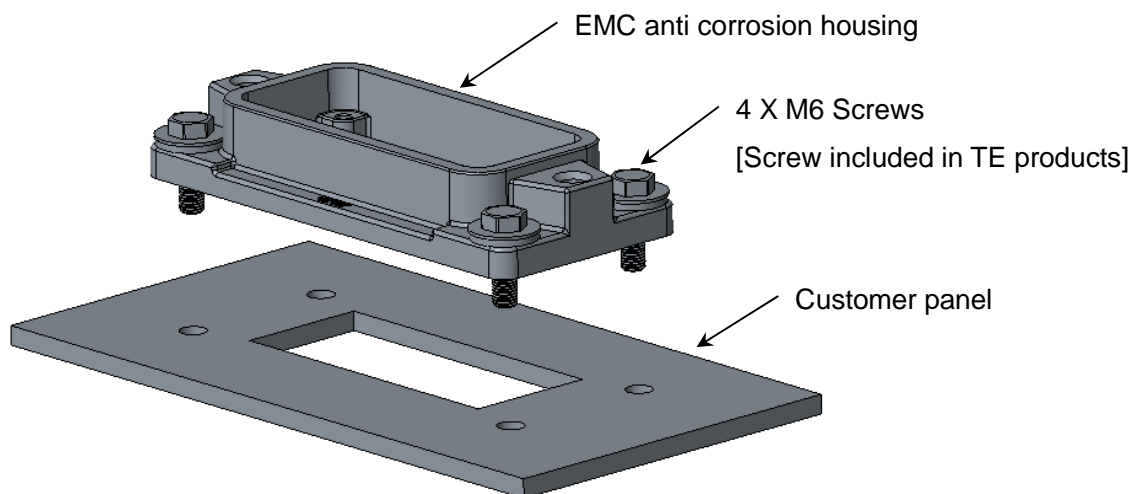

Figure: 16

➤ **Assembly female insert into EMC anti corrosion housing**

Fix female insert with 4 x M3 screws. Tightening torque refer to spec of female insert.

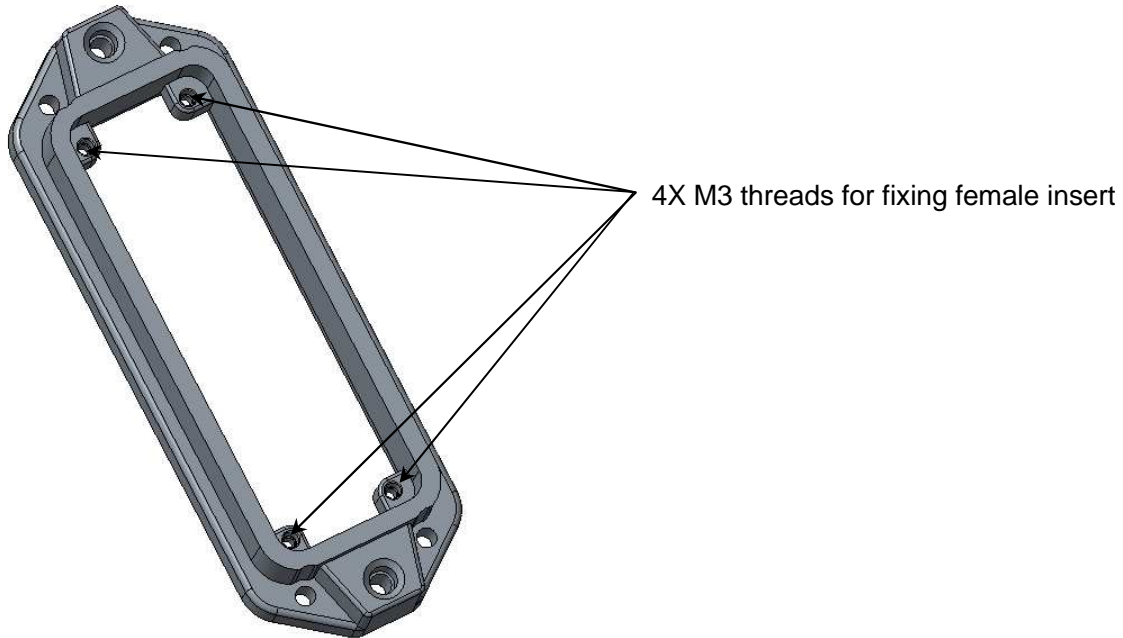

Figure: 17

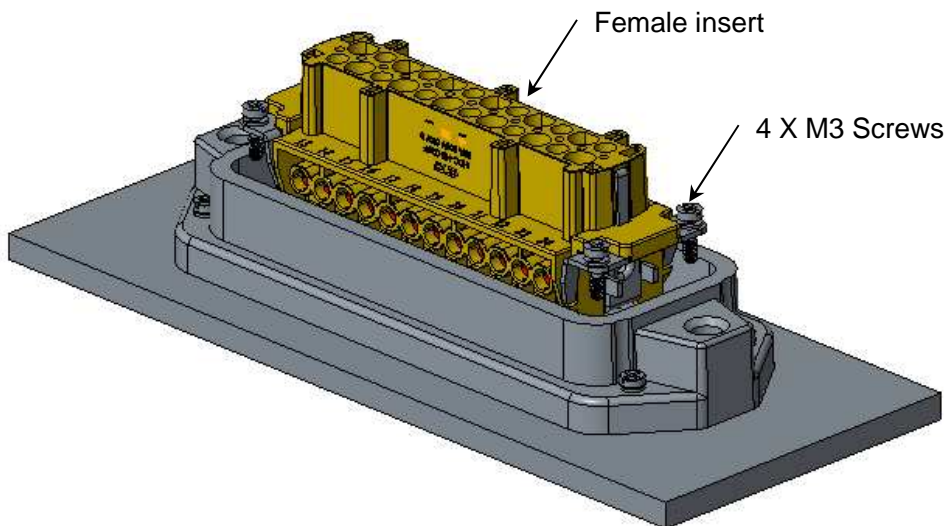

Figure: 18

Notes:

- Refer application spec of female insert separately and before fixing to housing, it should be well prepared.
- Whatever the type of housing or the type of female insert, they have same assembly process here.

➤ **Assembly male insert into EMC anti corrosion hood**

Fix female insert with 4 x M3 screws. Tightening torque refer to spec of male insert.

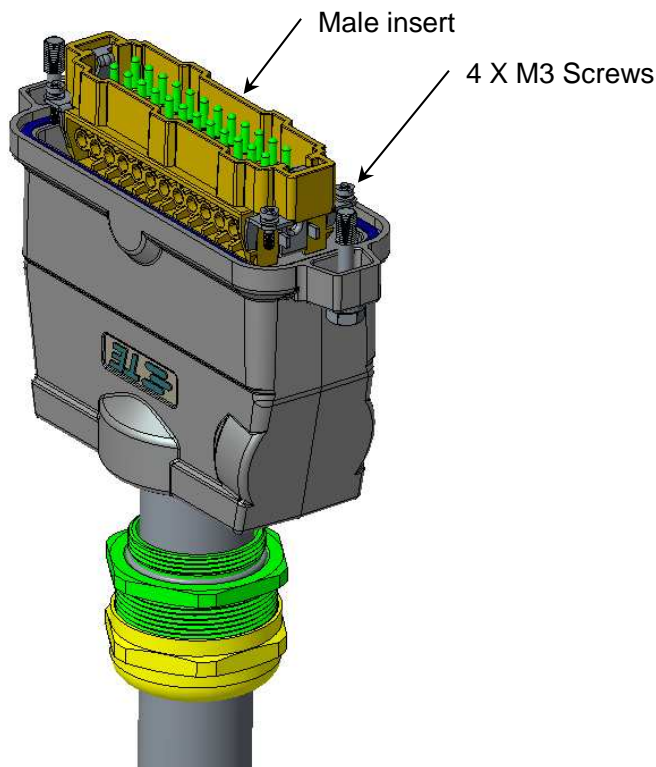
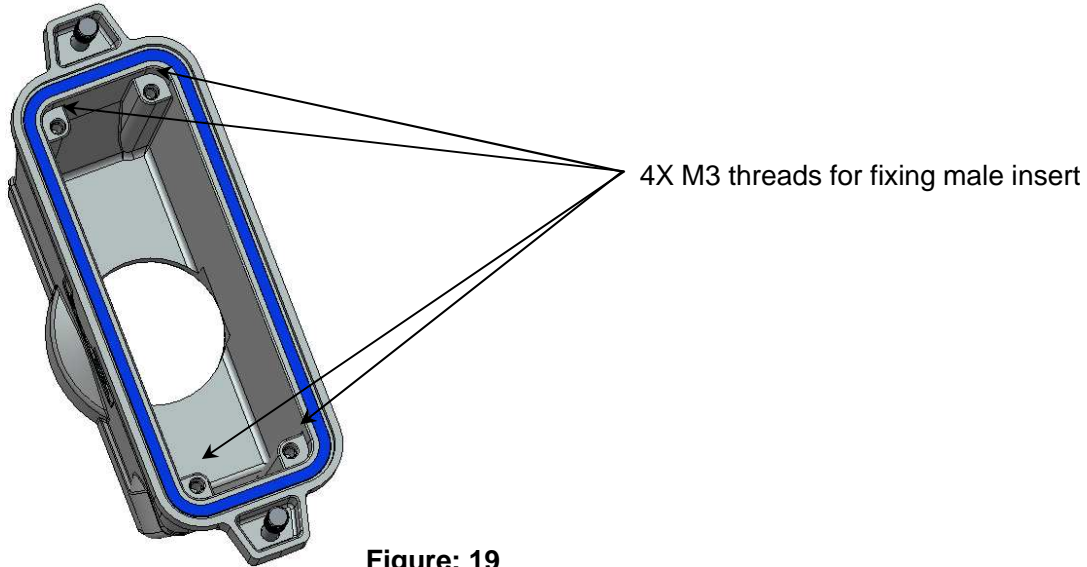

Notes:

- Refer application spec of male insert separately and before fixing to EMC anti corrosion hood, male insert should be well prepared.
- Whatever the type of EMC anti corrosion hood or the type of male insert, they have same assembly process here.

➤ **Assembly cable gland with EMC anti corrosion hood**

Fix cable gland to EMC anti corrosion hood. Tightening torque refer to spec of cable gland.

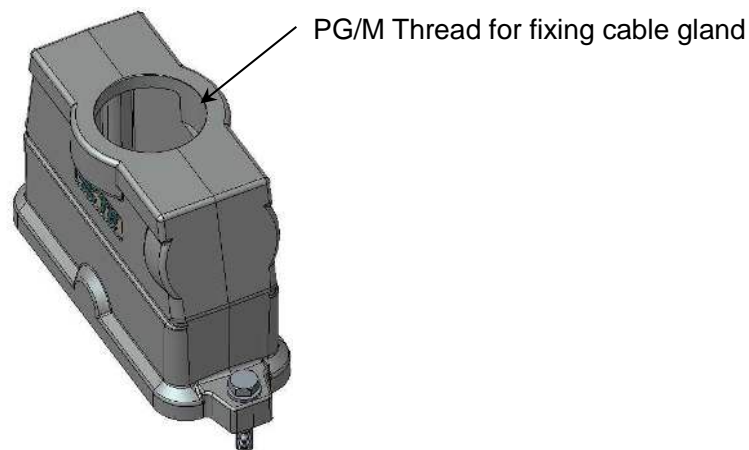

Figure: 21

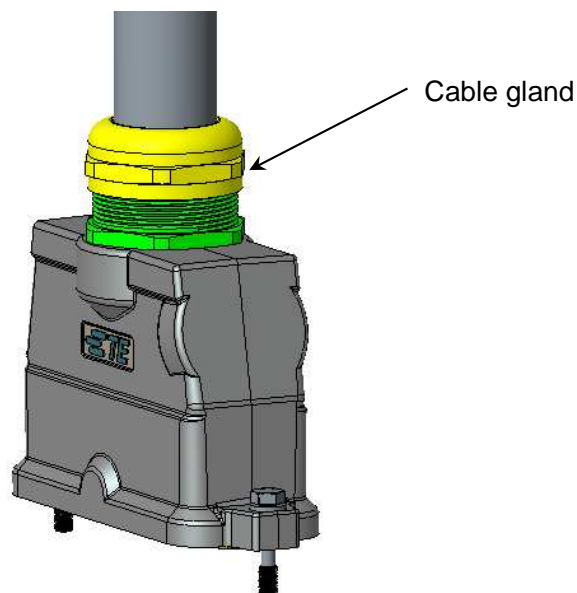

Figure: 22

Notes:

- Refer application spec of cable gland separately.
- Whatever the type of EMC anti corrosion hood or the type & size of thread hole, they have same assembly process here.

➤ **Assembly EMC anti corrosion hood with EMC anti corrosion housing**

Fix EMC anti corrosion hood to EMC anti corrosion housing with 2 x M6 screws. Tightening torque 4Nm

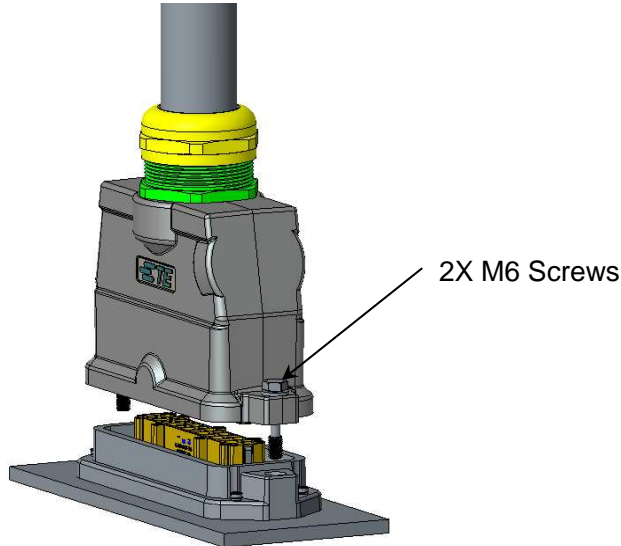



Figure: 23

Notes:

- Whatever the type of EMC anti corrosion hood & housing, they have same assembly process here.

6. STORAGE

The connectors should be stored in the air ventilation, no corrosive gas, no rain and no snow in the warehouse. Relative humidity: less than 85% RH.

NOTE Any conflict is found between this file and customer drawings, customer drawings are preferential.
 And please contact TE Connectivity related engineer if necessary.

----- End-----